

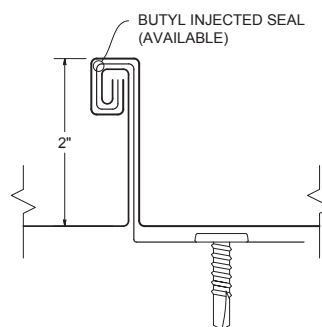

# MS-200™

## Metal Building/Open Framing Installation Guide

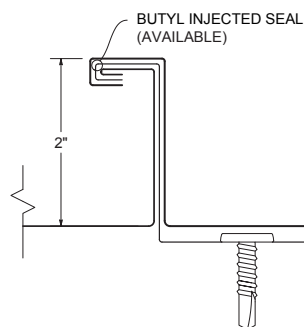

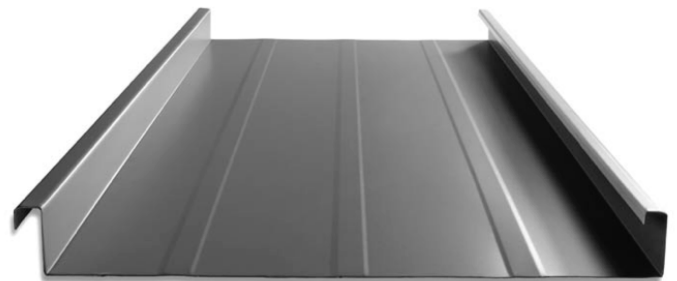
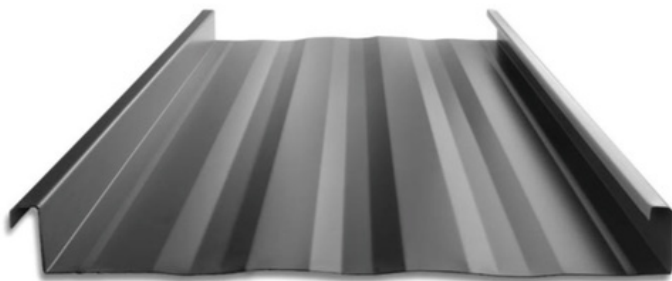
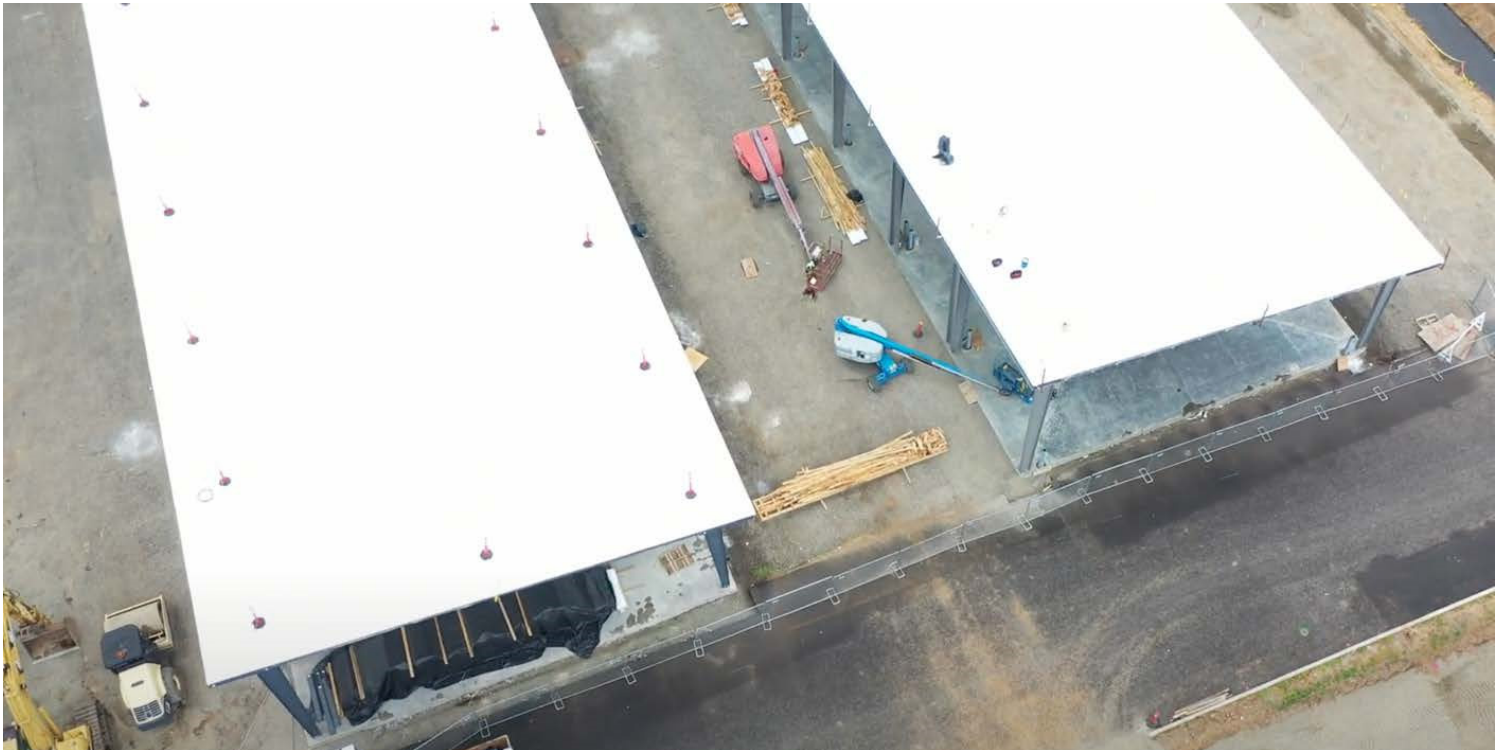

# IMPORTANT NOTICE

**READ THIS MANUAL COMPLETELY PRIOR TO BEGINNING THE INSTALLATION OF THE MS-200™ ROOFING SYSTEM. THE MANUFACTURER'S DETAILS MUST BE FOLLOWED AS A MINIMUM TO ENSURE APPROPRIATE WARRANTIES WILL BE ISSUED.**

**ALWAYS INSPECT EACH PANEL, AND ALL ACCESSORIES, BEFORE INSTALLATION. NEVER INSTALL ANY PRODUCT IF ITS QUALITY IS IN QUESTION. NOTIFY Taylor Metal Products (TMP) IMMEDIATELY IF ANY PRODUCT IS BELIEVED TO BE OUT OF TOLERANCE, SPECIFICATION, OR HAS BEEN DAMAGED DURING SHIPMENT.**

**IF THERE IS A CONFLICT BETWEEN PROJECT INSTALLATION DRAWINGS PROVIDED OR APPROVED BY THE MANUFACTURER (AND DETAILS IN THIS MANUAL), PROJECT INSTALLATION DRAWINGS WILL TAKE PRECEDENCE.**

## Ice Dam Disclaimer

TMP designs its standing seam roofs to meet the load requirements dictated by governing codes and project specifications, including applicable snow loads. However, TMP expressly disclaims responsibility for weathertightness or roof point loading issues or other hazards resulting from ice dam situations. Any time ice and snow can melt on the main body of the roof and refreeze at the eave or in the shadow of an adjacent wall, an ice dam situation may develop. In addition to local climate, ice dam formation is affected by many other factors, including but not limited to, roof insulation R value, roof panel color, interior temperature of building, heater location in building, eave overhangs, parapet walls, shading of building roof areas from adjacent trees, parapets, buildings, etc. These factors are design and maintenance issues and are outside the control of TMP. TMP specifically disclaims any liability for damage due to ice dam formation, although the following issues should be taken into consideration concerning standing seam roofs installed in freezing climates:

- Always use field seamed panels. These machine-folded seams are more durable when subjected to occasional icing.
- Eliminate “cold” eave overhangs and parapet walls from the building design. Roof overhangs outside the heated envelope of the building will tend to be colder than the roof areas over the heated envelope. Simple roof designs are preferred. Parapet walls at the eave allow ice and snow to collect due to shading effects and the lower roof temperatures caused thereby.
- Make sure the interior of the building is adequately insulated and the heating is properly distributed. Inadequate insulation in the roof and/or improper heat distribution causes heat flow through the main body of the roof. On days when the temperature is below freezing, this heat gain can cause ice and snow to melt and refreeze at the eave where the roof is colder.
- Lay out the building to prevent the eaves and other roof areas from being shaded during the winter. This may mean eliminating adjacent trees or reconsidering roof geometries.
- Consider using self-regulating heating cables at the eaves to mitigate the effects of ice dams.
- On building designs using attics, over-insulate the attic floor and provide adequate ventilation in the attic. This will reduce heat transfer through the roof resulting in more consistent roof temperatures between eave and field of roof.
- Increase the degree of diligence with respect to underlayment materials at roof areas prone to icing. This may include valleys, eaves, dormers and roof areas near dormers, parapets and the like where shading may occur.

The engineering data contained herein is for the expressed use of customers and design professionals. Along with this data, it is recommended that the design professional have a copy of the most current version of the North American Specification for the Design of Cold-Formed Steel Structural Members published by the American Iron and Steel Institute to facilitate design. This Specification contains the design criteria for cold-formed steel components. Along with the Specification, the designer should reference the most current building code applicable to the project jobsite in order to determine environmental loads. If further information or guidance regarding cold-formed design practices is desired, please contact the manufacturer.

Descriptions and specifications contained herein were in effect at the time this publication was approved for printing. In a continuing effort to refine and improve products, TMP reserves the right to discontinue products at any time or change specifications and/or designs without incurring obligation. **To ensure you have the latest information available, please inquire or visit our website at [www.taylormetal.com](http://www.taylormetal.com).** Application details are for illustration purposes only and may not be appropriate for all environmental conditions, building designs or panel profiles. Projects should be designed to conform to applicable building codes, regulations and accepted industry practices. If there is a conflict between this manual and project erection drawings, the erection drawings will take precedence.

<b>Section</b>	<b>Page(s)</b>
<b>Roofing System</b>	
Panel Specifications .....	1
Architectural & Engineering Information .....	2
Insulation/Thermal Spacer Selection Chart .....	3
<b>General Information</b>	
Parts and Guidelines .....	4-13
Preparatory Requirements .....	14
Unloading .....	15
Panel Handling and Storage .....	16
Proper Handling, Storage, and Maintenance .....	17-18
<b>Installation Sequence</b>	
Step 1.....	19
Step 2.....	20
Step 3.....	21
Step 4.....	22
Step 5.....	23
Step 6.....	24
Step 7.....	25
Step 8.....	26
Step 9.....	27
Step 10.....	28
<b>Special Installation Techniques</b>	
Pipe Penetration .....	29-34
<b>Details Open Framing</b>	
Fixed Eave with Hang on Gutter .....	35
Fixed Eave with Eave Trim .....	36
Floating Ridge .....	37
Floating Vented Ridge .....	38
Rake .....	39
Rake with Cleat .....	40
Parapet Rake .....	41
Parapet Floating High Side Eave .....	43
<b>Custom Flashings</b> .....	44

## Panel Specifications

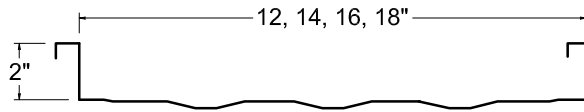

With Striations

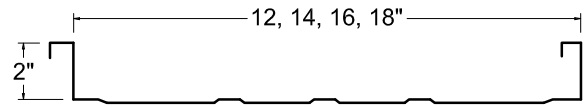

With Accent Ribs

Coverage Width – 12” - 14” – 16” – 18”

Minimum Slope - 1/2:12

Panel Attachment - Low, High (Floating)

Panel Substrate – Zinalume/Galvalume® /G-90

Gauge - Standard: 24; Optional: 22

Finishes - Striated (standard)\* or Accent Ribs (Inquire about other options)

Coatings – Duranar® (PPG) or Kynar 500® (PVDF)

### PRODUCT SELECTION CHART

MS-200™	Duranar®/Kynar 500® (PVDF)		Zinalume®/Galvalume® (G90)	
	24	22	24	22
Gauges				
12” Wide	■	■	■	■
14” Wide	●	●	●	●
16” Wide	●	●	●	●
18” Wide	●	●	●	●

DURANAR and the PPG logo are registered trademarks of PPG Industries Ohio, Inc.

Galvalume is a registered trademark of BIEC International, Inc.

Zinalume is a registered trademark of Bluescope Steel Limited. Steelscape LLC holds exclusive rights to the ZINCALUME trademark name within the U.S.

● — Available in any quantity.

■ — Minimum quantity may be required.

Other colors, finishes, gauges, and materials available; please inquire.

\* Striated panels are standard to reduce “oil canning”.

### Caution

Diaphragm capabilities and purlin stability are not provided by manufactures MS-200™ roof system. Therefore, other bracing may be required to conform to A.I.S.C. or A.I.S.I. specifications.

## Architectural & Engineering Information

1. MS-200™ is a mechanically seamed roof system. MS-200™ panels are available in 12", 14", 16" and 18" widths. Factory applied mastic inside of female leg of panel and in the clip saddle are standard.
2. MS-200™ is a structural roofing panel. This panel can be installed directly over purlins or bar joists. It does not require a solid substructure for support. The MS-200™ roof system has several different UL 580 construction numbers, and is ASTM E1592 and FM Global tested.
3. MS-200™ is recommended for roof slopes of 1/2:12 or greater.
4. TMP can factory form panels up to a maximum of 62' and can on site roll panels continuously up to 150'. This reduces the need for end laps. Elite warranties are required to be installed without end laps. Contact TMP for end lap options.
5. Heavier gauges, striations, accent ribs and installation over a solid deck minimize oil canning. Industry standard is for a minimum 24-gauge material. Striations are standard to reduce oil canning. Oil canning is not a cause for rejection. Panels are available with the option of striated with Accent ribs.
6. Substructure must be on an even plane from eave to ridge to avoid panel distortion (1/4" in 20', 3/8" in 40' tolerance).
7. All panels require end sealant at eave and valley conditions; however, for illustration purposes, this sealant is not shown on all drawings.
8. For proper fastener application, see Product Checklist.
9. All perimeter trim dimensions in this manual are based on a wall panel thickness of 1 1/4" ("PBR" Panel). Any variation from this wall panel thickness may affect the perimeter trim dimensions.
10. The information in this manual is believed to be correct and accurate.
11. Drawings in this manual utilize the low floating clip. Clips are available in low or high fixed, & low or high floating and utility (solid decks).
12. Avoid restricting the thermal expansion and contraction of the MS-200™ panels. (i.e.: Do not attach panel to the substructure at both the eave and ridge.) However, panels must be attached to the substructure at one end to prevent their sliding downslope. Contact TMP for Drag Load calculations.
13. MS-200™ panels are not designed to be work platforms. Avoid any unnecessary foot traffic on MS-200™ panels. If foot traffic is required, protect the roof panels by using soft soled shoes and some type of roof pad, temporary deck, or walkway.
14. **WARNING:** Light transmitting panels are not designed or intended to bear the weight of any person walking, stepping, standing or resting on them. THE MANUFACTURER DISCLAIMS ANY WARRANTY OR REPRESENTATION, EXPRESS OR IMPLIED, that any person can safely walk, step, stand or rest on or near these light transmitting panels or that they comply with any OSHA regulation.
15. Typically, when wood decks are used, they are temporarily protected by the installation of a moisture barrier over the wood deck.
16. If utility clips are to be used, the MS-200™ panel will lay tight to the wood/metal deck. If tin tabs are used to attach the moisture barrier to the deck, they must be covered with duct tape or some other material to prevent them from rusting the back side of the panels. Also, plastic washers may "telegraph" through the panels.
17. Field cutting of the panels should be avoided where possible. If field cutting is required, the panels must be cut with nibblers, snips, or shears to prevent edge rusting. Do not cut the panels with abrasive saw blades, grinders, or torches.

### Caution

Application and design details are for illustration purposes only and may not be appropriate for all environmental conditions or building designs. Projects should be engineered to conform to applicable building codes, regulations, and accepted industry practices.

### Caution

The use of any field seaming machine other than that recommended by the manufacturer will damage the panels and void all warranties and will void all engineering data. The Installer should carefully follow the manufacturers operating instructions and report any panel discrepancies to TMP immediately.

**Low Floating System** - With or without 3/8" thermal spacer. See Insulation/Thermal Spacer Selection Chart below.

**High Floating System** - With 3/8", 5/8" or 1" thermal spacer. See Insulation/Thermal Spacer Selection Chart below.

Thermal calculations should be performed for each project to ensure that the thermal movement of the roof is not greater than the floating clip's capacity. Various densities of blanket insulation may affect the installation and or the appearance of a metal roof system. The installer is responsible for selecting the proper clip and thermal spacer for their conditions.

## Insulation/Thermal Spacer Selection Chart

Insulation Thickness	Low Floating System	High Floating System
No Insulation	3/8" Thermal Spacer	Not Recommended
3" Insulation	Thermal Spacer Not Recommended	5/8" Thermal Spacer Recommended
4" Insulation	Thermal Spacer Not Recommended	3/8" Thermal Spacer Recommended
6" Insulation	Not Recommended	Thermal Spacer Not Recommended

### Warning

As with all standing seam roof systems, sound attenuation (example: blanket insulation) should be installed between the panels and open framing, such as purlins or joists, to prevent "roof rumble" during windy conditions.

Applications over solid deck such as rigid insulation over a metal deck or a wood deck may require additional acoustical consideration to ensure that thermal vibration noises are isolated from the building interior. This is especially important if the bottom of the deck is left open to the interior, in cathedral ceiling applications or when the attic space is used as a return air plenum.

A vapor retarder may be necessary to protect roofing components when high humidity is a factor. The need for a vapor retarder, as well as the type, placement and location should be determined by an architect or engineer. The following are examples of conditions that may require a vapor retarder: (A) a project where outside winter temperatures below 40 degrees F. are anticipated and where average winter interior relative humidity of 45% or greater is expected. (B) building usages with high humidity interiors such as indoor swimming pools, textile manufacturing operations, food, paper or other wet-process industrial plants. (C) Construction elements that may release moisture after the roof is installed, such as interior concrete, masonry or plaster work and fuel burning heaters.

# General Information

## Product Checklist



### MS 200™ Panel

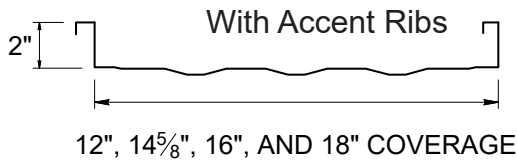
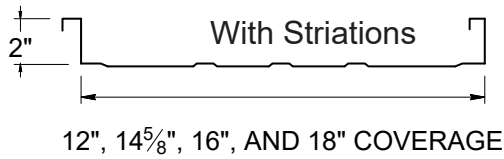

### Back-up Plate

For use at ridge, end laps, and high side eave  
16 ga Galvanized

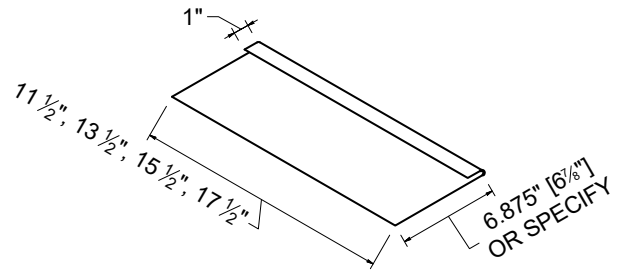

- 11-1/2": TMS200BUP\_16-GA11
- 13-1/2": TMS200BUP\_16-GA13
- 15-1/2": TMS200BUP\_16-GA15
- 17-1/2": TMS200BUP\_16-GA17

### Low Float Clip AMSCLIPF200FM

Low - For use with or without 3/8" thermal spacer, utility (wood/metal decks)

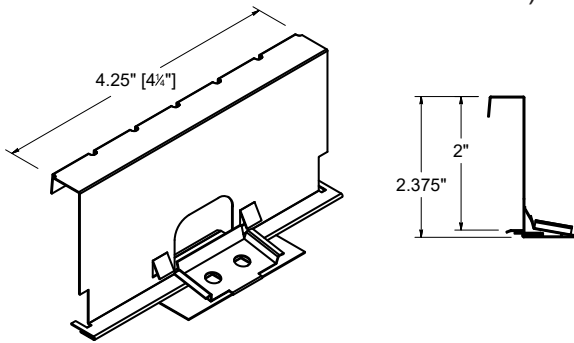

### High Float Clip AMSCLIPF300FM

High - For use with 3/8", 5/8" or 1" thermal spacer

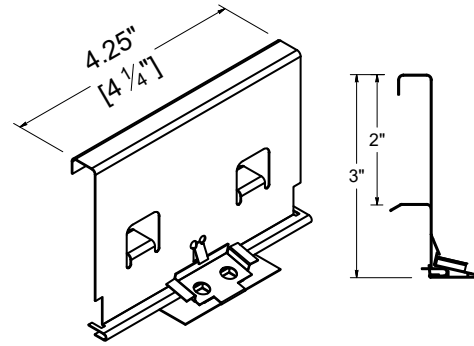

### Utility Clip AMSCLIPF200NT

For use with solid decks only

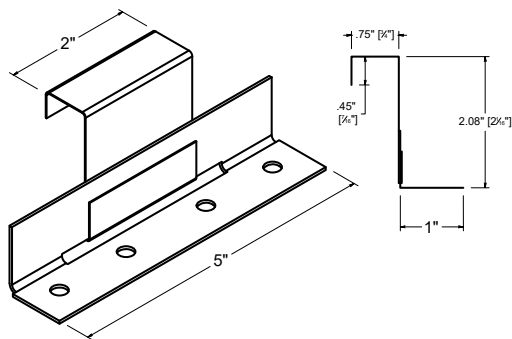

### Low & High Rake Support

TMS200SGS16-GA\*

TMS200SGSH16-GA\*\*

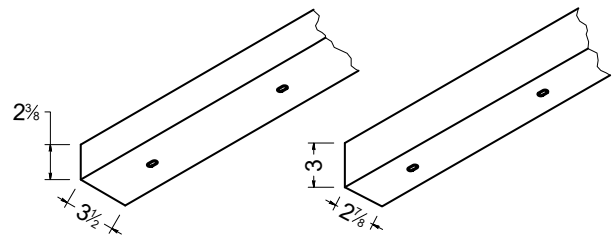

- 10' 0" length
- Factory slots
- \*For use with low clip
- 16 gauge galvanized
- \*\*For use with high clip



**Low Eave Plate**  
TMS200GPL16-GA

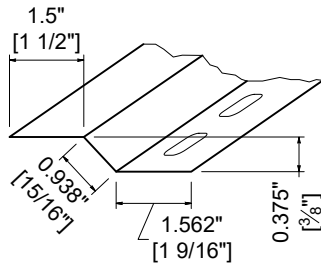

- 10' 0" length
- 16 gauge galvanized

**High Eave Plate**  
TMS200GPH16-GA

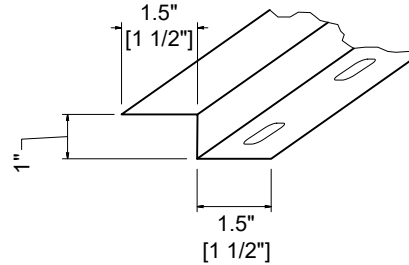

- 10' 0" length
- 16 gauge galvanized

**Low Float Eave Plate**  
TMS200GPFL16-GA

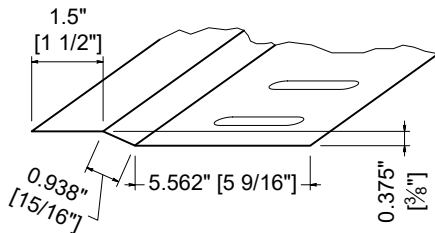

- 10' 0" length
- 16 gauge galvanized

**High Float Eave Plate**  
TMS200GPFH16-GA

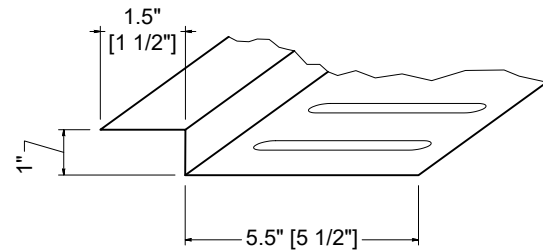

- 10' 0" length
- 16 gauge galvanized

**Low Mid Slope Fixed Plate**  
TMS200MFPL16-GA

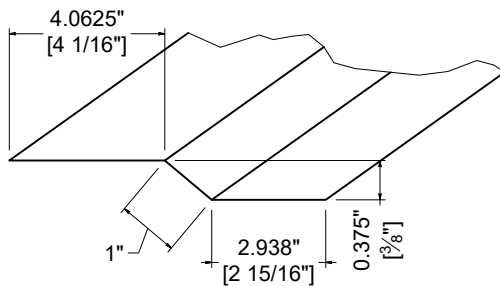

- 10' 0" length
- 16 gauge galvanized

**High Mid Slope Fixed Plate**  
TMS200MFPH16-GA

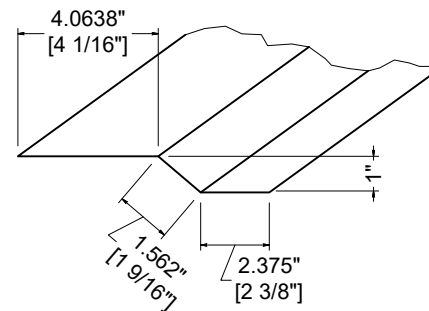

- 10' 0" length
- 16 gauge galvanized

# General Information

## Product Checklist

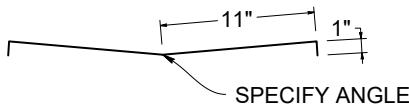
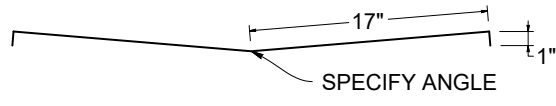
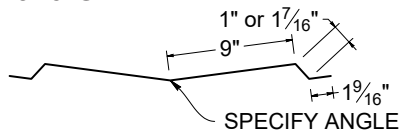
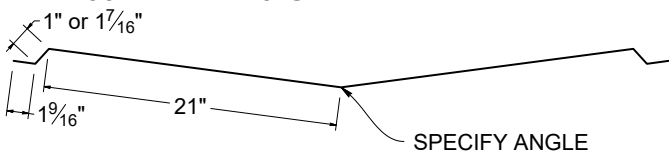
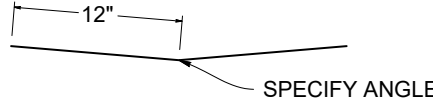
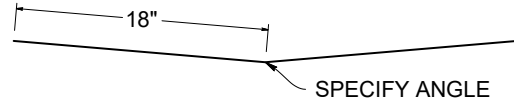
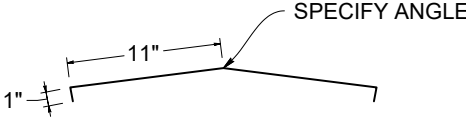
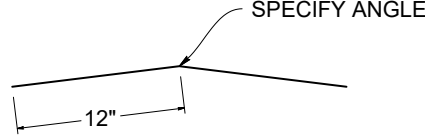
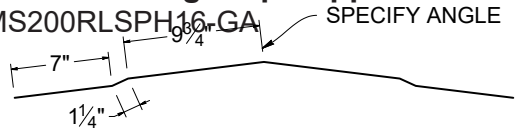
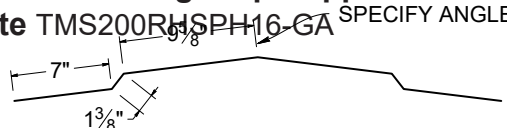

<p><b>Low Valley Support Plate</b> TMS200VSPL1116-GA</p>  <p>10' length 16 ga galvanized Use over purlins/joists</p> <p style="text-align: right;">Standard Width</p>	<p><b>Low Valley Support Plate Extended</b> TMS200VSPL1716-GA</p>  <p>10' length 16 ga galvanized Use over purlins/joists</p> <p style="text-align: right;">Extended Width</p>
<p><b>High Valley Support Plate</b> TMS200VSPL916-GA</p>  <p>10' length 16 ga galvanized Use over purlins/joists</p> <p style="text-align: right;">Standard Width</p>	<p><b>High Valley Support Plate Extended</b> TMS200EVSPL2116-GA</p>  <p>10' length 16 ga galvanized Use over purlins/joists</p> <p style="text-align: right;">Extended Width</p>
<p><b>Low Valley Support Plate</b> TMS200VSPL1216-GA</p>  <p>10' length 16 ga galvanized Use over rigid insulation</p> <p style="text-align: right;">Standard Width</p>	<p><b>Low Valley Support Plate Extended</b> TMS200EVSPL1816-GA</p>  <p>10' length 16 ga galvanized Use over rigid insulation</p> <p style="text-align: right;">Extended Width</p>
<p><b>Low/High Floating Hip Plate</b> TMS200HSP1116-GA</p>  <p>10' length 16 ga galvanized Use over purlins/joists</p>	<p><b>Low/High Float Hip Support Plate</b> TMS200HSP1216-GA</p>  <p>10' length 16 ga galvanized Use over solid substrate</p>
<p><b>Low Fixed Ridge/Hip Support</b> TMS200RLSPH16-GA</p>  <p>10' length 16 ga galvanized Use with all solid substrate</p>	<p><b>High Fixed Ridge/Hip Support Plate</b> TMS200RHSPH16-GA</p>  <p>10' length 16 ga galvanized Use with all solid substrate</p>

### 2 X 2 X 16 GA BACKUP ANGLE

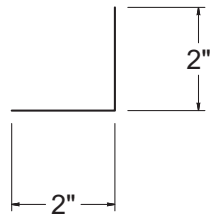

10' length  
16 ga galvanized

### End Dam

• 24 gauge Painted

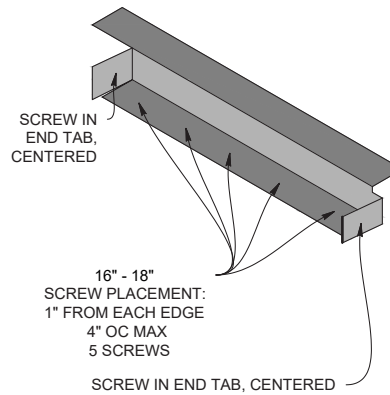

TMS20012ED24 -  
12" panel  
4 screws

TMS20014ED24 -  
14" panel  
4 screws

TMS20016ED24 -  
16" panel  
5 screws

TMS20018ED24 -  
18" panel  
5 screws

### Triple Bead Butyl Tape ABTTBM

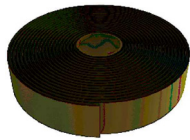

2-1/2" Butyl Tape

- 3/16" x 2-1/2 W' x 20'
- For use at valley when using exposed fasteners
- For use with roof curbs
- At end laps when warranty not required

### Double Bead Butyl Tape ABTDBM

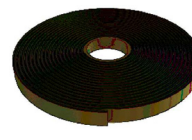

7/8" Butyl Tape

- 3/6" X 7/8" X 25'
- For use at eave, ridge, end laps and trim connections

### Up Ender



AUPEND11.200 - 12" Panel  
AUPEND13.200 - 14" Panel  
AUPEND15.200 - 16" Panel  
AUPEND11.200 - 18" Panel

### Tube Sealant







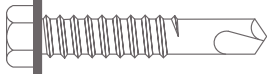
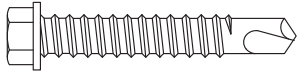

Butyl Caulking:  
ABC® - Non Skinning Butyl Caulk  
ABCS® - Skinning Butyl Caulk  
ADLS® - Polyethylene (Paintable/UV resistant)  
AM1S® - Polyether Adhesive (For end laps on underlayment)

# General Information

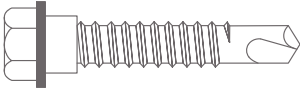
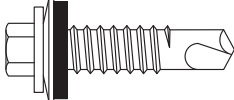
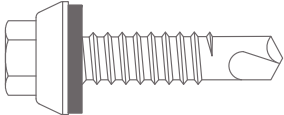
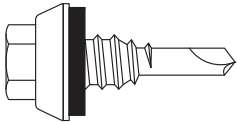
## Product Checklist

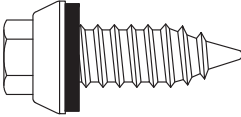
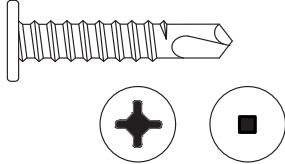

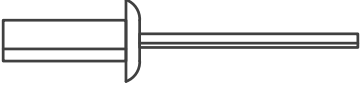
<p><b>Fastener #1</b> ASTNW025125 NO WASHER</p>  <p>1/4"-14 x 1 1/4" Self Driller 5/16" Hex Washer Head with no washer</p>	<p><b>Fastener #2</b> ASTNW025150</p> <ul style="list-style-type: none"> <li>• Clip to purlin (Up to 4" insulation between panel and purlin) Rake trim to roof panel</li> </ul>  <p>1/4"-14 x 1 1/2" Self Driller 5/16" Hex Head with 5/8" O.D. washer</p>
<p><b>Fastener #3</b> ADP5025125 NO WASHER DP 5</p>  <p>12-24 x 1 1/4" with #5 Drill Point 5/16" Hex Washer Head with no washer</p>	<p><b>Fastener #4</b> ADP5025150 NO WASHER DP 5</p> <ul style="list-style-type: none"> <li>• Clip to purlin (Up to 4" insulation between panel and bar joist) Rake trim to roof panel</li> </ul>  <p>12-14 x 1 1/2" with #5 Drill Point 5/16" Hex Washer Head with no washer</p>
<p><b>Fastener #5</b> ASB025125 SHOULDER BOLT/TEK</p>  <p>1/4"-14 x 1 1/4" Shoulder Tek® 2 Self Driller 5/16" Hex Washer Head, with no washer</p>	<p><b>Fastener #6</b> ASWFSAB100 TYPE A</p> <ul style="list-style-type: none"> <li>• Eave plate to eave strut</li> <li>• Mid-slope fixed plate to purlin</li> <li>• Rake support to angle (Fixed system only)</li> </ul>  <p>1/4"-14 x 1" Self Driller 5/16" Hex Head with 5/8" O.D. washer</p>
<p><b>Fastener #7</b> AST025125 FLANGE SEALHEAD</p>  <p>1/4"-14 x 1 1/4" Long Life Self Driller 5/16" Hex Washer Head, with sealing washer</p>	<p><b>Fastener #8</b> AST025087 LAP TEK FLANGE/ SEAL HEAD</p> <ul style="list-style-type: none"> <li>• Ridge and other flashing to outside closure</li> <li>• Gutter to panel</li> <li>• Gutter to strap</li> <li>• Trim to trim connections</li> <li>• Sculptured eave trim to panel</li> </ul>  <p>1/4"-14 x 7/8" Long Life Lap Tek® Self Driller 5/16" Hex Washer Head, with sealing washer</p>

<p><b>Fastener #9</b> ASGS100-AC TYPE AB</p> <ul style="list-style-type: none"> <li>• Use in place of Fasteners 7 &amp; 8 at all strip outs</li> </ul>  <p><b>1/4"-14 x 1 1/4" Long Life Self Driller</b> 5/16" Hex Washer Head, with sealing washer</p>	<p><b>Fastener #10</b> ASPHT12100 PANCAKE TEK</p> <ul style="list-style-type: none"> <li>• Rake angle to purlin</li> <li>• Hip and valley support plates to purlins</li> <li>• Valley flashing to valley support plate</li> </ul>  <p><b>12 x 1" #2 Phillips or Square Drive</b> Pancake Head Driller</p>
<p><b>Fastener #11</b> APR-AC</p> <ul style="list-style-type: none"> <li>• Trim to trim connections</li> </ul>  <p><b>Stainless Steel Pop Rivet</b> 1/8" diameter x 3/8" grip range</p>	<p><b>Fastener #12</b> APR46-AC</p> <ul style="list-style-type: none"> <li>• Outside closure to angle on floating hip detail</li> </ul>  <p><b>Stainless Steel Pop Rivet</b> 1/8" diameter x 3/16" grip range</p>
<p><b>Fastener #10</b> APRC #64</p> <ul style="list-style-type: none"> <li>• Dekstrip to Expansion Ridge/Expansion Lap</li> </ul>  <p><b>#64 x 1/4" Grip Range Rivet</b> Stainless Closed End Rivet</p>	<p><b>Fastener #10</b> AMA-AC</p> <ul style="list-style-type: none"> <li>• Special application fastener</li> <li>• For attaching trim to masonry walls</li> </ul>  <p><b>1/4" x 1 1/4" Nail Drive Masonry Anchor</b></p>

# General Information

## Installation Guideline



ALL HEMS ON THIS PAGE ARE OPEN

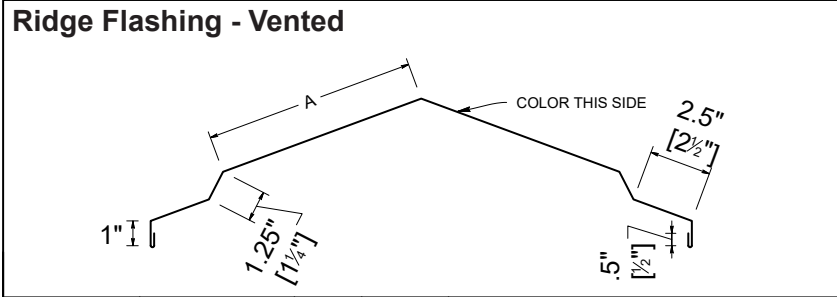

PART NO.	ROOF PITCH	DIM A	SO	NOTES
TMS 200RV1	1/2 - 3 3/4:12	4 1/2"	19 1/2"	FOR USE WITH PERFORATED VENT DRIP 18" PEAK PURLIN SPACING
TMS 200RV2	3 13/16 - 6:12	5 1/2"	20 1/2"	
TMS 200RV3	1/2 - 3 3/4:12	6 3/4"	24"	FOR USE WITH PERFORATED VENT DRIP 24" PEAK PURLIN SPACING
TMS 200RV4	3 13/16 - 6:12	8 1/2"	27 1/2"	

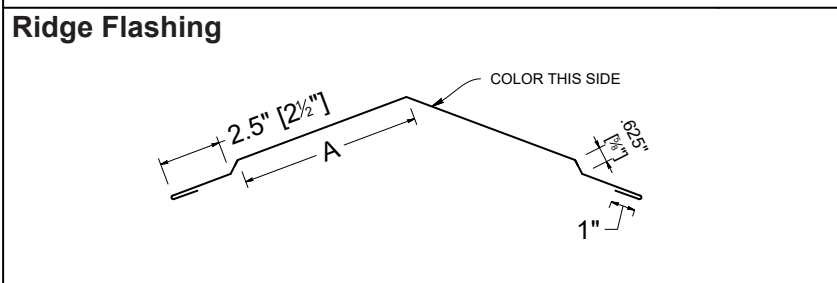
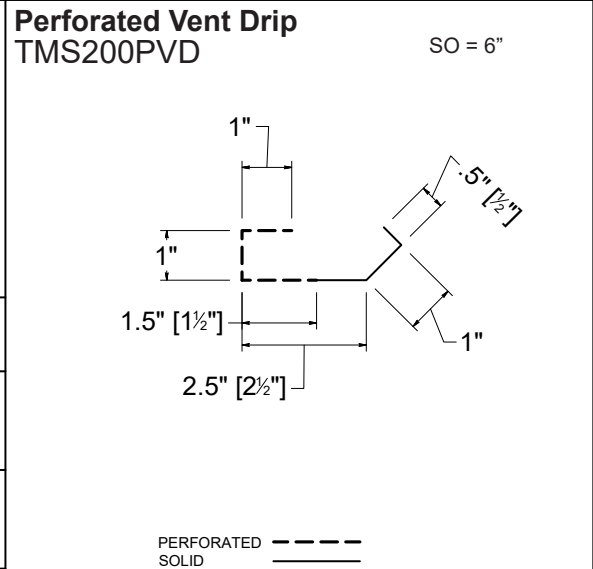

PART NO.	ROOF PITCH	DIM A	SO	NOTES
TMS 200R1	1/2 - 3 3/4:12	2 7/8"	14"	FOR USE WITHOUT VENTILATOR 18" PEAK PURLIN SPACING
TMS 200R2	3 13/16 - 6:12	4 1/8"	16 1/2"	
TMS 200R3	1/2 - 3 3/4:12	6 1/8"	20 1/2"	FOR USE WITHOUT VENTILATOR 24" PEAK PURLIN SPACING
TMS 200R4	3 13/16 - 6:12	6 7/8"	22"	

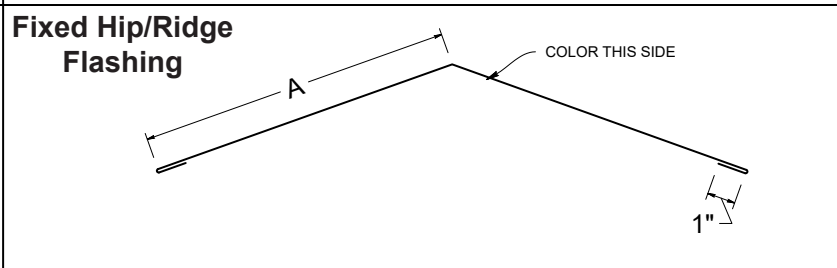
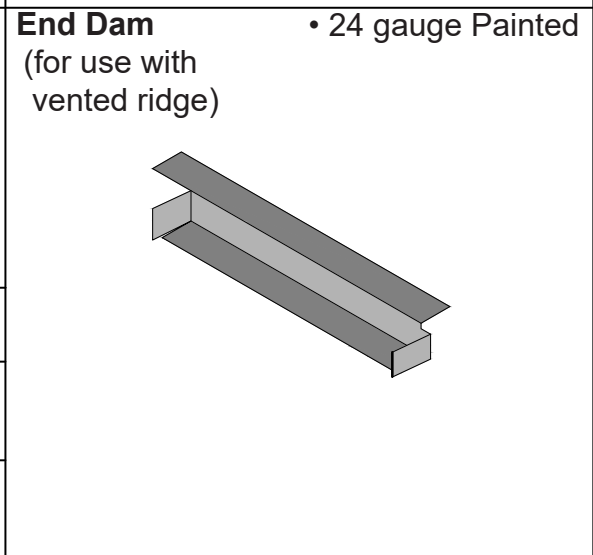

PART NO.	ROOF PITCH	DIM A	SO	NOTES
TMS 200R1	1/2 - 3 3/4:12	6"	14"	FOR USE WITH VENT MATERIAL 18" PEAK PURLIN SPACING
TMS 200R2	3 13/16 - 6:12	7"	16"	
TMS 200R3	ALL PITCHES	11"	24"	FOR USE WITH VENT MATERIAL 24" PEAK PURLIN SPACING

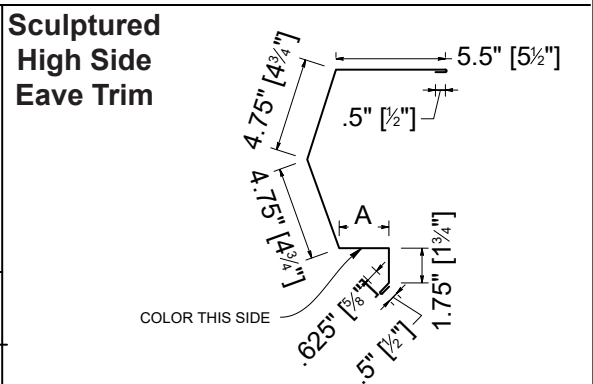

PART NO.	ROOF PITCH	DIM A	SO
TMS200SHE1	1/4 - 1 3/4 :12	2"	20 3/8"
TMS200SHE2	1 13/16 - 4 :12	3 11/16"	22 1/16"

ALL HEMS ON THIS PAGE ARE OPEN

### Standard Sculptured Gutter

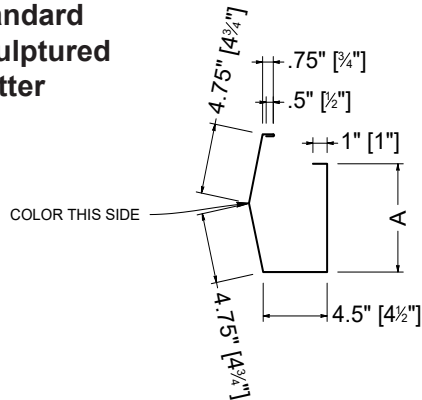

PART NO.	ROOF PITCH	DIM A	SO
TMS200SG1	1/2 - 4 :12	7 5/8"	23 9/16"
TMS200SG2	4 9/16 - 6 :12	7 15/16"	24 3/16"

### Gutter Strap TMS200SGS24

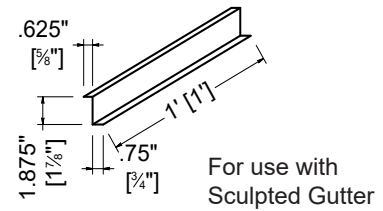

### Gutter Ends Left/Right TMS200SGECL TMS200SGECR



- Use with all Sculptured or Style
- Gutters
- End Caps will be made to fit gutter ordered
- Specify left or right
- Specify gutter part number

### Sculptured Rake Trim TMS200SR

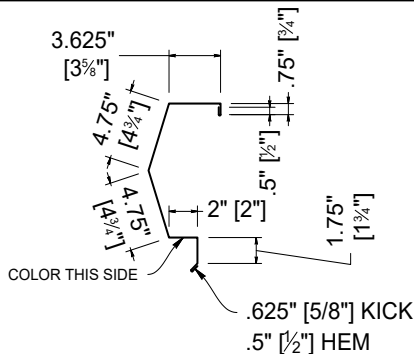

SO = 19 1/4"

### Variable Termination

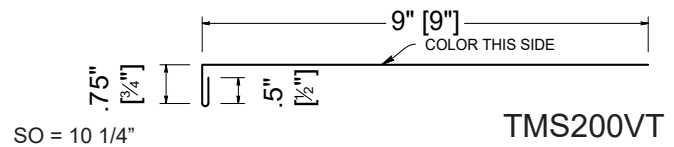

SO = 10 1/4"

TMS200VT

### High Wind Rake Slide TMS200RHS

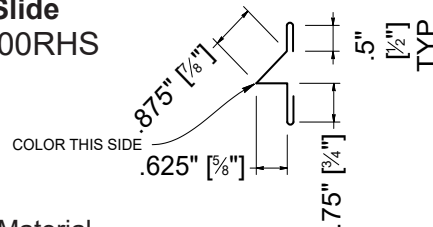

24 Ga Material

SO = 4"

### Sculptured Eave Trim TMS200SE

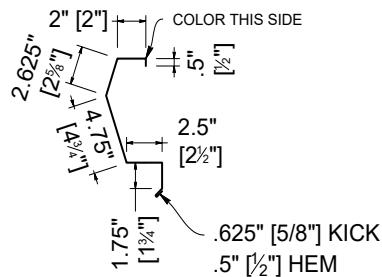

SPECIFY PITCH

SO = 15 1/4"

### Eave with Extended Drip Edge TMS200EEH

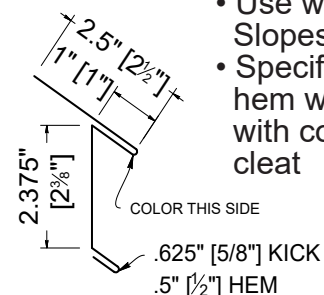

- Use with Roof Slopes 1/2 - 6:12
- Specify open hem when using with continuous cleat

SPECIFY PITCH

SO = 7"

### Box High Side Eave Trim TMS200BHE

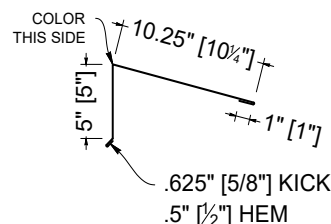

SPECIFY PITCH

SO = 17 3/8"

### Box Eave Trim TMS200EH

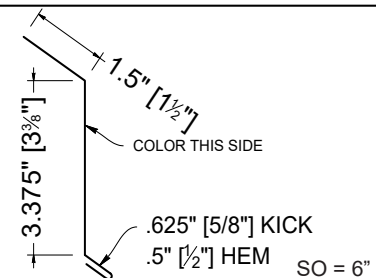

SPECIFY PITCH

SO = 6"

ALL HEMS ON THIS PAGE ARE OPEN

<p><b>Box Rake Trim</b> TMS200BR</p> <p>SO = 9 5/8"</p>	<p><b>Parapet Rake Cleat</b> TMS200PRC</p> <p>SO = 3 1/2"</p>																					
<p><b>Box Gutter with Drip Edge</b> TMS200EBG</p> <p>SPECIFY PITCH SO = 23"</p>	<p><b>Gutter Strap</b> TMS200EBGS</p> <ul style="list-style-type: none"> <li>• Use with TMS200EBG Box Gutter with Drip Edge</li> <li>• 24 ga material</li> </ul>																					
<p><b>Fixed Parapet High Side Eave Flashing</b> TMS200PHE</p> <p>SPECIFY PITCH SO = 12"</p>	<p><b>Gutter End Cap</b> TMS200EGECL TMS200EGECR</p> <ul style="list-style-type: none"> <li>• Use with TMS200EBG Box Gutter with Drip Edge</li> <li>• Specify left or right</li> </ul>																					
<p><b>Parapet Rake Flashing</b></p> <table border="1" data-bbox="431 1703 764 1892"> <thead> <tr> <th>PART NO.</th> <th>DIM A</th> <th>SO</th> </tr> </thead> <tbody> <tr> <td>TMS200PR1</td> <td>3"</td> <td>9 1/2"</td> </tr> <tr> <td>TMS200PR2</td> <td>5"</td> <td>11 1/2"</td> </tr> <tr> <td>TMS200PR3</td> <td>7"</td> <td>13 1/2"</td> </tr> </tbody> </table>	PART NO.	DIM A	SO	TMS200PR1	3"	9 1/2"	TMS200PR2	5"	11 1/2"	TMS200PR3	7"	13 1/2"	<p><b>Floating Parapet High Side Eave Flashing</b></p> <table border="1" data-bbox="1130 1740 1463 1892"> <thead> <tr> <th>PART NO.</th> <th>DIM A</th> <th>SO</th> </tr> </thead> <tbody> <tr> <td>TMS200PHE1</td> <td>3.5"</td> <td>13"</td> </tr> <tr> <td>TMS200PHE2</td> <td>4.5"</td> <td>14"</td> </tr> </tbody> </table>	PART NO.	DIM A	SO	TMS200PHE1	3.5"	13"	TMS200PHE2	4.5"	14"
PART NO.	DIM A	SO																				
TMS200PR1	3"	9 1/2"																				
TMS200PR2	5"	11 1/2"																				
TMS200PR3	7"	13 1/2"																				
PART NO.	DIM A	SO																				
TMS200PHE1	3.5"	13"																				
TMS200PHE2	4.5"	14"																				



ALL HEMS ON THIS PAGE ARE OPEN

**Offset Cleat**  
TMS200OC

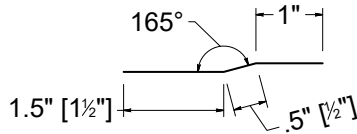

24 Gauge Material

SO = 3"

**Continuous Cleat**  
TMS200CC-AC  
TMS200CC-ZA

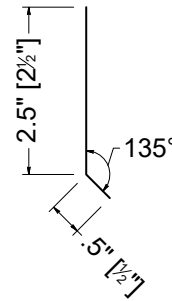

24 Gauge Material

SO = 3"

**Sawcut Reglet**  
TMS200SR

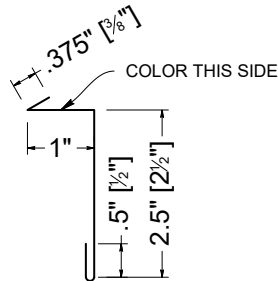

24 Gauge Material

SO = 4 3/8"

**Alternate Surface Mount Reglet/  
Counter Flashing**  
TMS200EBGS

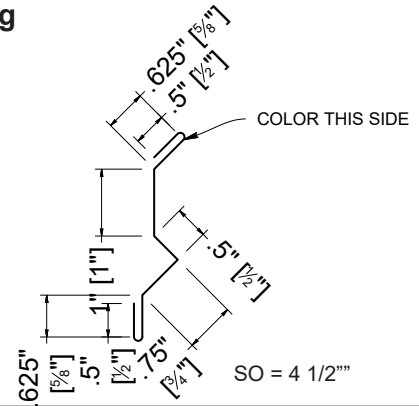

24 Gauge Material

SO = 4 1/2"

**Box Panel Cap Trim**  
TMS200BPC

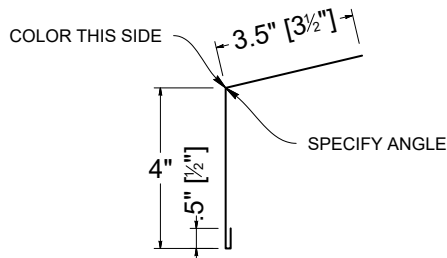

24 Gauge Material

SO = 8"

**Offset Panel Cap Trim**  
TMS200OPC

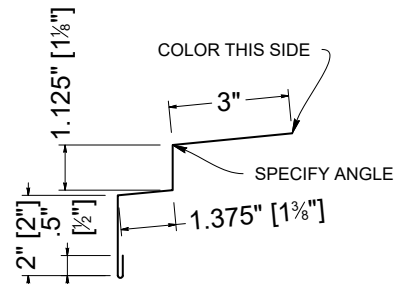

24 Gauge Material

SO = 8"

**Low & High Standard Valley**  
TMS200VE

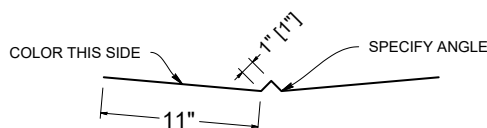

24 Gauge Material

SO = 24"

**Low & High Standard Extended Valley**  
TMS200VEE

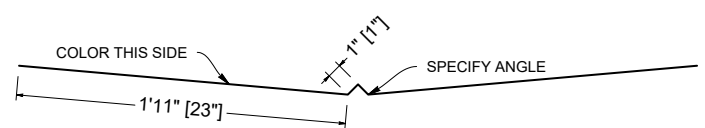

24 Gauge Material

SO = 48"

## Preparatory Requirements

1. For the purpose of this manual, we have assumed that the MS-200™ roof will be installed over purlins and an eave gutter will be installed. Please refer to the Design Section of the manuals for details of MS-200™ over other substrates.
2. A rake angle or an alternate structural flat surface must be installed on top of the purlins to accept the rake support.
3. All primary and secondary framing must be erected, plumbed and squared with bolts tightened according to accepted building practices.
4. The substructure (eave to ridge) must be on plane (1/4" in 20' or 3/8" in 40' tolerance).
5. It is critical that the purlins or bar joists at the ridge and end-laps be located exactly as detailed and that they are straight from rafter to rafter. Any mis-location or bowing of these members can cause the fasteners at the ridge or end-laps to foul as the panels expand and contract.
6. The manufacturer recommends the use of a screw gun with a speed range of 0-2000 RPM to properly install all fasteners referenced in this manual. Tools rated to 4000 RPM should never be used for self-drilling fasteners typically supplied with metal roof and wall systems.
7. Field cutting of the panels should be avoided where possible. If field cutting is required, the panels must be cut with nibblers, snips, or shears to prevent edge rusting. Do not cut the panels with saws, abrasive blades, grinders, or torches. All metal shavings must be removed from panel surfaces immediately.

### NOTE

It is the responsibility of the erector to install this roof using safe construction practices that follow OSHA regulations. The manufacturer is not responsible for the performance of this roof system if it is not installed in accordance with the instructions shown in this manual. Deviations from these instructions and details must be approved in writing by the manufacturer.

### CAUTION

Diaphragm capabilities and purlin stability are not provided by the MS-200™ roof system. Therefore, other bracing may be required

### CAUTION

Avoid restricting the thermal expansion and contraction of the MS-200™ panels. (i.e. Do not attach panel to the substructure at both the eave and ridge.)

### WARNING

Light transmitting panels are not designed or intended to bear the weight of any person walking, stepping, standing or resting on them. THE MANUFACTURER DISCLAIMS ANY WARRANTY OR REPRESENTATION, EXPRESS OR IMPLIED, that any person can safely walk, step, stand or rest on or near these light transmitting panels or that they comply with any OSHA regulation.

## Unloading

Upon receiving material, check shipment against shipping list for shortages and damages. The manufacturer will not be responsible for shortages or damages unless they are noted on the shipping list.

Each bundle should be lifted at its center of gravity. Where possible, bundles should remain branded until final placement on roof. If bundles must be opened, they should be retied before lifting.

When lifting bundles with a crane, a spreader bar and nylon straps should be used. **NEVER USE WIRE ROPE SLINGS, THEY WILL DAMAGE THE PAELS.**

When lifting bundles with a forklift, forks must be a minimum of five feet apart. Do not transport open bundles. Drive slowly when crossing rough terrain to prevent panel buckling

**CAUTION**  
Improper unloading and handling of bundles and crates may cause bodily injury or material damage. The manufacturer is not responsible for bodily injuries or material damages during unloading and storage.

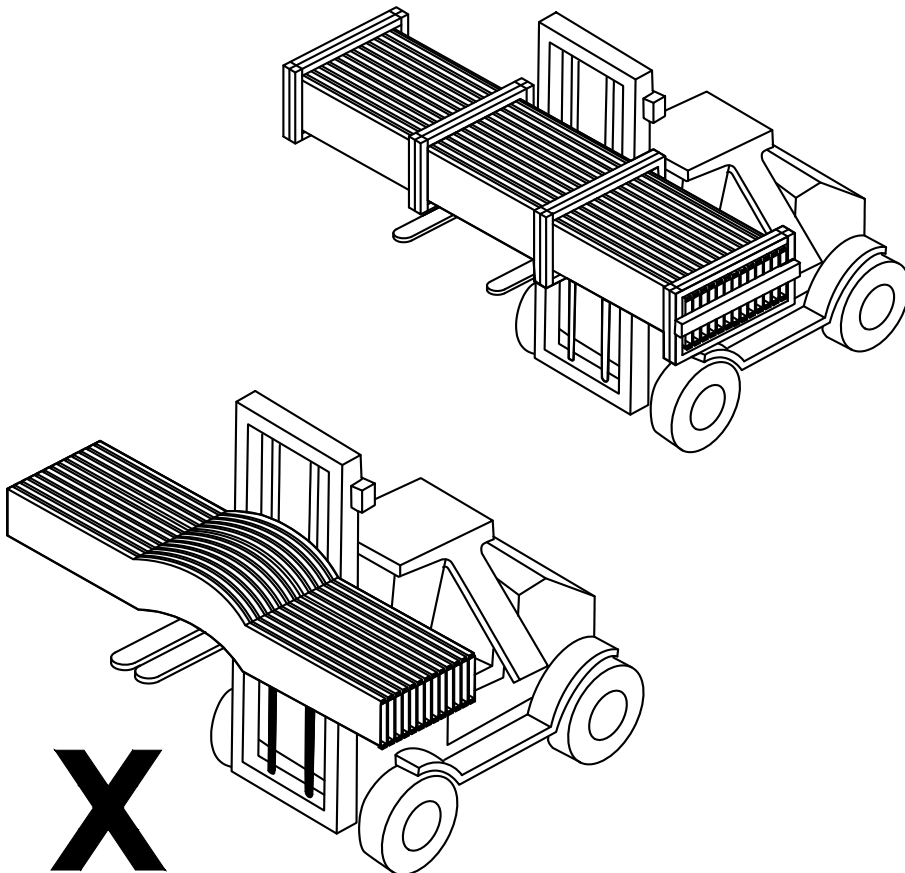
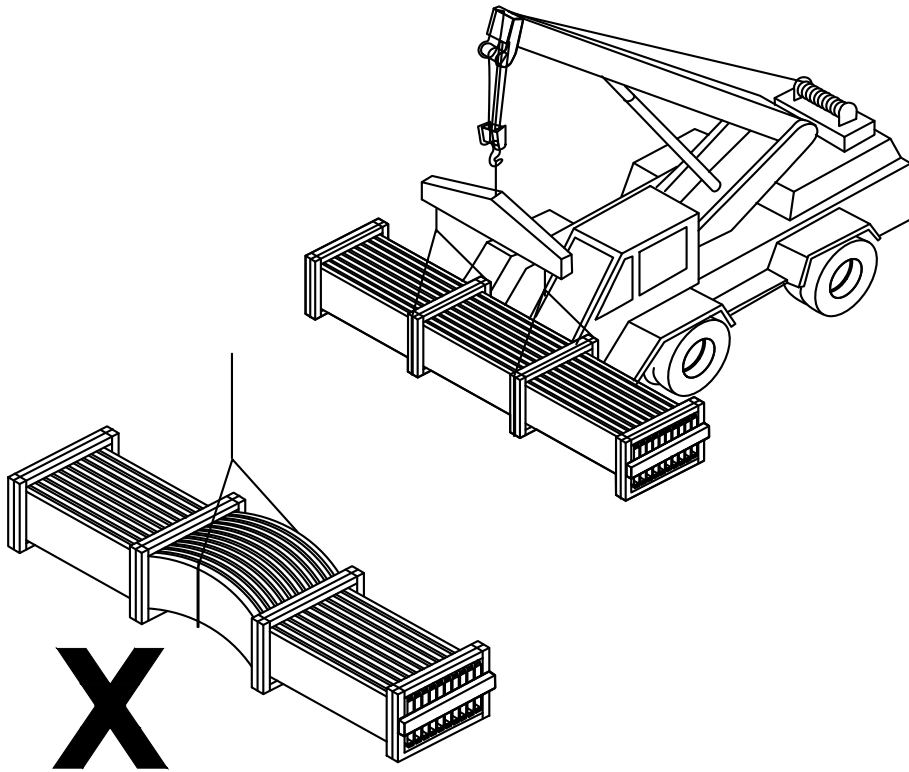

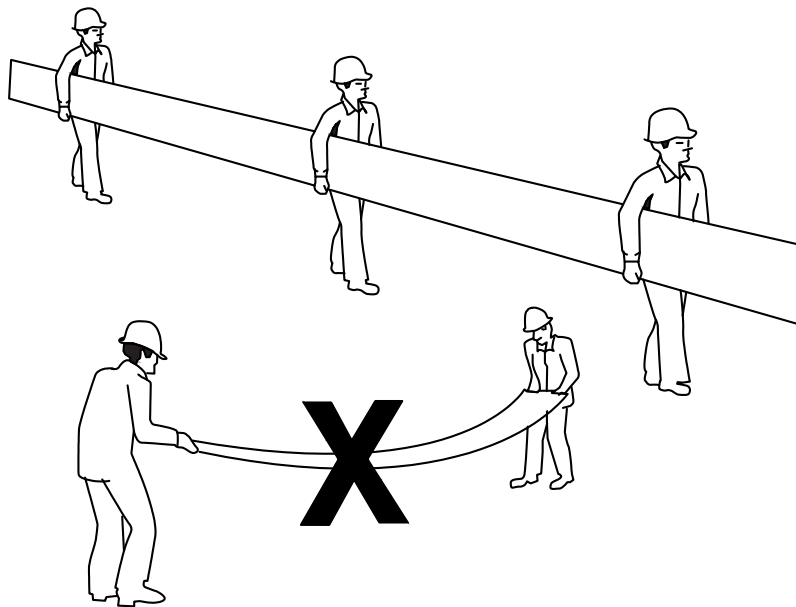

## Handling and Storage Requirements

Standing on one side of the panel, lift it by the seam. If the panel is over 10' long, lift it with two or more people on one side of the panel to prevent buckling.

**DO NOT PICK PANELS UP BY THE ENDS FLAT SIDE UP!**

Store bundled sheets off the ground sufficiently high to allow air circulation beneath bundle and to prevent rising water from entering bundle. Slightly elevate one end of bundle. Prevent rain from entering bundle by covering with tarpaulin, making provision for air circulation between draped edges of tarpaulin and the ground. Prolonged storage of sheets in a bundle is not recommended. If conditions do not permit immediate erection, extra care should be taken to protect sheets from white rust or water marks.

Check to see that moisture has not formed in-side the bundles during shipment. If moisture is present, panels should be uncrated and wiped dry, then restacked and loosely covered so that air can circulate between the panels.

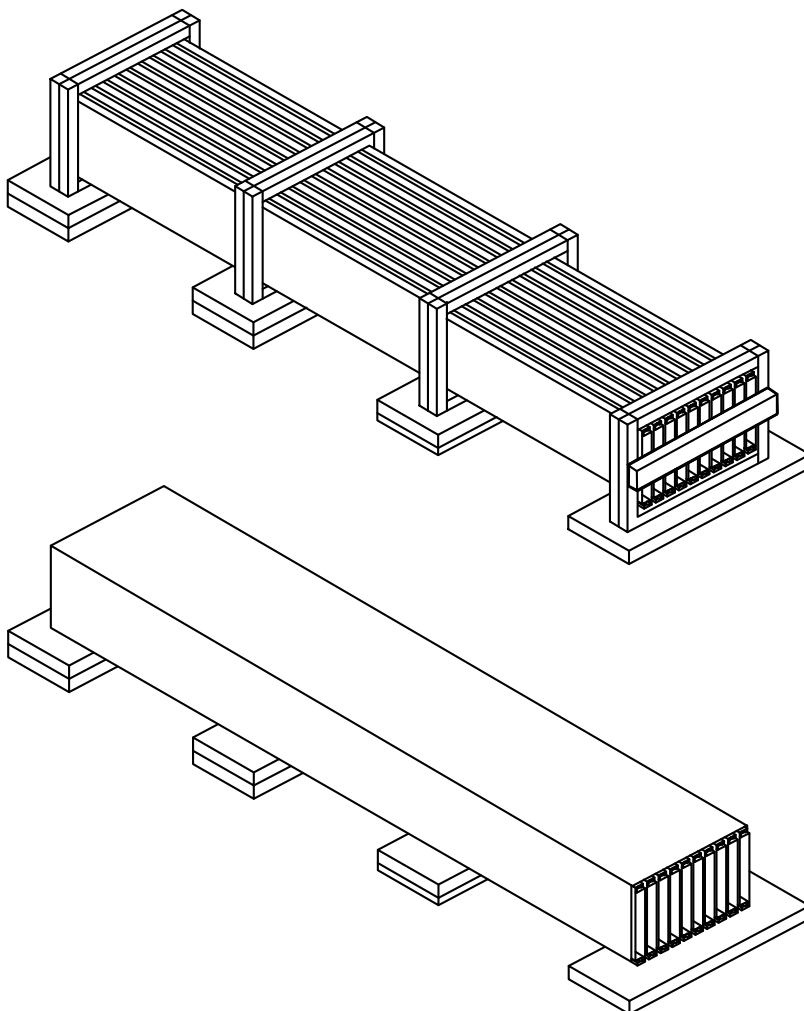

## Proper Handling, Storage, and Maintenance of Painted & Zincalume®/Galvalume® Panels

### Panel Handling

- All panel bundles must be inspected during unloading and carrier advised immediately if damage is noted.
- Never unload or move panel bundles that have been opened without adequately clamping them. Without the banding to hold the bundle stable, panels may shift during unloading or movement, causing the bundle to fall.
- Never use wire slings to unload or move panel bundles.
- When unloading or moving panel bundles over 20' long, a spreader bar may be required. It is the erector's responsibility to determine the location and number of lift points required to safely unload or move panel bundles.
- When handling individual panels, always wear protective gloves. OSHA safety regulations must be followed at all times.
- When cutting panels, always wear all required safety equipment such as safety glasses and gloves. Cut panels with nibblers, shears or snips. Do not use abrasive blade saws as these will damage the protective coating causing the panel edge to rust which will void the substrate and Paint warranties. Drilling fasteners into panels will create metal filings that will rust and create an unsightly stain. Metal filings must be removed by sweeping or wiping down panels immediately after installation to avoid this occurrence

### Panel Storage

- If water is permitted to enter panel bundles, it is necessary to open bundles, separate the panels and dry all surfaces.
- Store bundled panels off the ground sufficiently high to allow air circulation beneath bundle and to prevent rising water from entering bundle. Slightly elevate one end of bundle.
- Prevent rain from entering bundle by covering with tarpaulin, making provision for air circulation between draped edges of tarpaulin and the ground.
- Prolonged storage of panels in a bundle is not recommended. If conditions do not permit immediate erection, extra care should be taken to protect panels from white rust or water marks. If panels have not been erected within three weeks of receipt, the panels should be removed from the bundle for inspection. Condensation may cause damage to panels. The manufacturer's paint and substrate warranties do not cover damage caused by improper panel storage.

### Panel Maintenance

- Never allow panels to come into contact with or water runoff from dissimilar materials such as copper, lead, or graphite. These materials will cause galvanic corrosion of the panels and will void the warranty. This includes treated wood and AC condensate, both of which contain copper compounds. This also applies to painted panels.
- Always use long life fasteners in all exposed fastener applications. Non long-life fasteners can rust through the panel at each exposed fastener location. Use of non-long life fasteners in exposed applications will void the Paint warranties.
- Panels should be protected against exposure to masonry products, strong acids or bases and solvents. Exposure to these agents may etch or stain panels and cause painted panels to blister or peel.
- Never allow anyone to apply any coating or patching material to the panel surface. These products may contain chemicals that will adversely affect the protective coating. Also, water may become trapped between the coating material and the panel, causing premature corrosion.

If you have any question as to proper methods to use in the handling, storage or maintenance of these panels, call your nearest manufacturer representative

## NOTICE

Uniform visual appearance of Zinalume®/Galvalume® cannot be guaranteed. The Zinalume®/Galvalume® coating is subject to variances in spangle from coil to coil which may result in a noticeable shade variation in installed panels. The Zinalume®/Galvalume® coating is also subject to differential weathering after panel installation. Panels may appear to be different shades due to this weathering characteristic. If uniform visual appearance is required, the manufacturer recommends that our pre-painted panels be used in lieu of Zinalume®/Galvalume®. Shade variations in panels manufactured from Acrylume®/Galvalume Plus® coated material do not diminish the structural integrity of the product. These shade variations should be anticipated and are not a cause for rejection.

## STEP 1

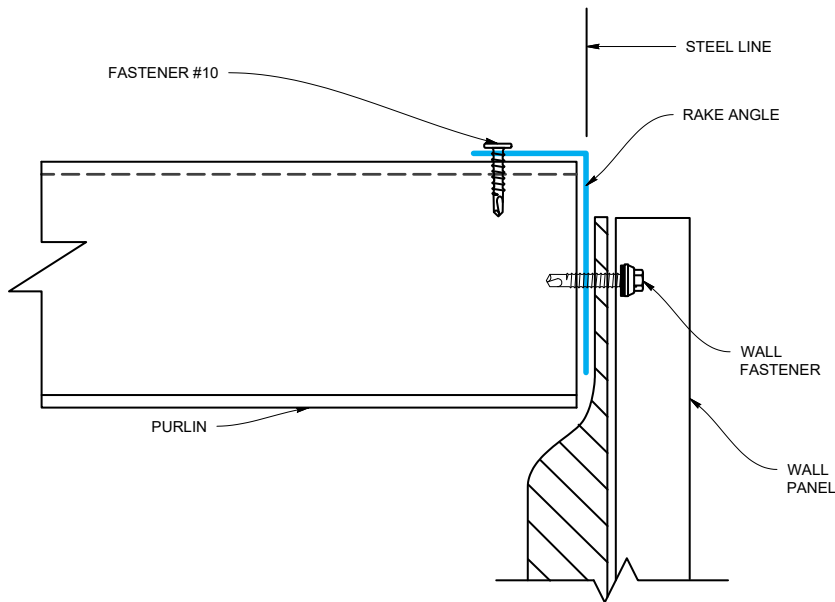
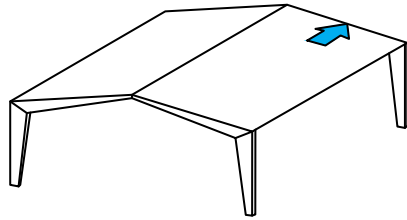

### Rake Angle Support

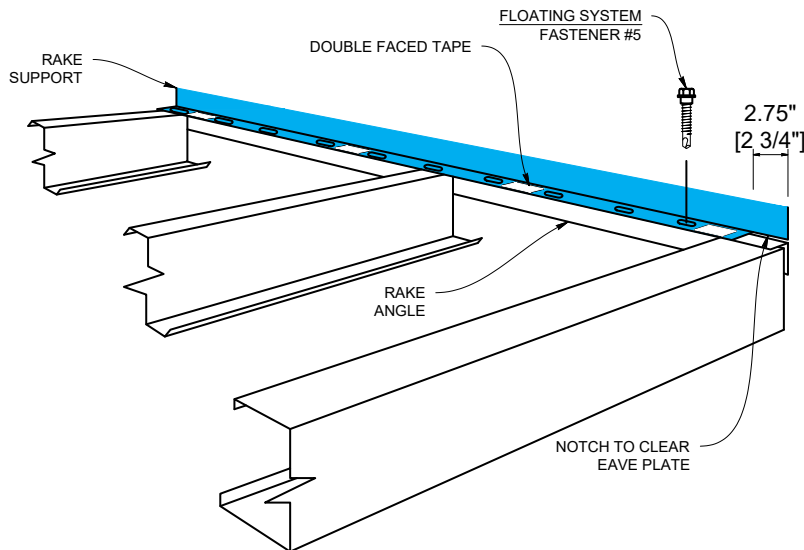

### Rake Support Attachment

## RAKE ATTACHMENT

Attach the rake angle to the purlin with Fastener #10.

Attach the rake support on top of the rake angle with the proper self-drilling fasteners (See "Rake Support Fastener Requirements" Below) on 2'-0" on centers with a fastener in the first and last prepunched slot. The vertical leg is to be installed flush with the steel line.

IT IS IMPORTANT THAT THE RAKE SUPPORT IS INSTALLED STRAIGHT AND SQUARE WITH THE EAVE AS IT CONTROLS THE ALIGNMENT OF THE ROOF SYSTEM.

Install 6" long pieces of double faced tape (not by Manufacturer) on 3'-0" centers to the top of the horizontal leg of the rake support. This will help hold the insulation in place at the rake if vinyl faced insulation is used.

### RAKE SUPPORT FASTENER REQUIREMENTS

Fixed System - Fastener #1  
Floating System - Fastener #5

### IMPORTANT!

All primary and secondary framing must be installed, plumbed, and bolts tightened prior to sheeting.

### CAUTION

(For Floating Systems Only)  
It is important that shoulder fasteners are installed through the CENTER of the slotted holes of the rake support to allow for expansion and contraction.

## STEP 2

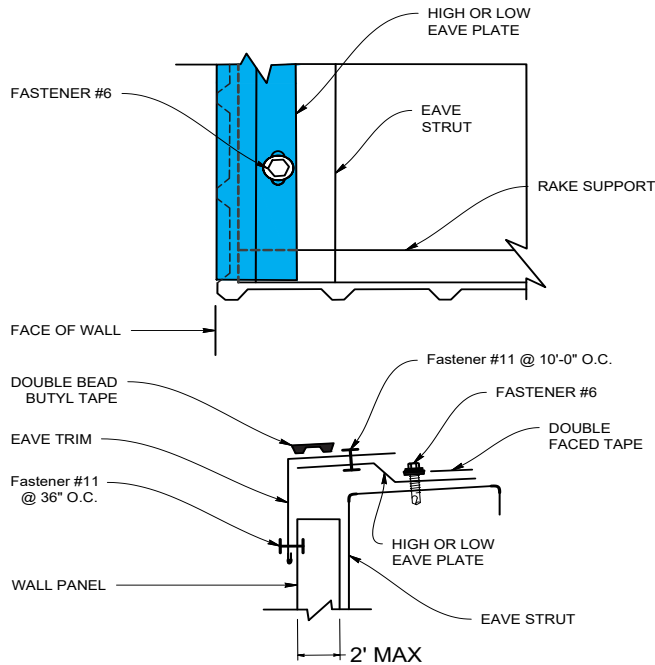
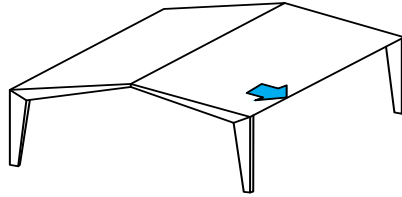

**WALL PANEL INSTALLED BEFORE ROOF**

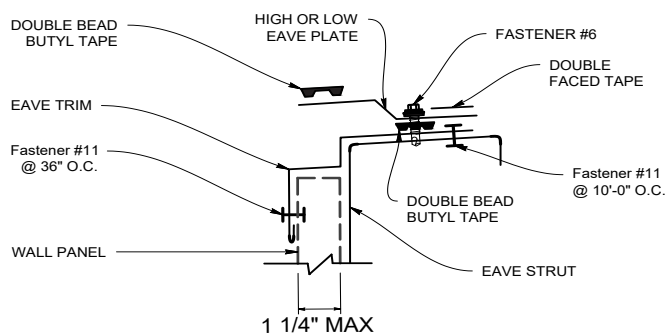

**WALL PANEL INSTALLED AFTER ROOF**

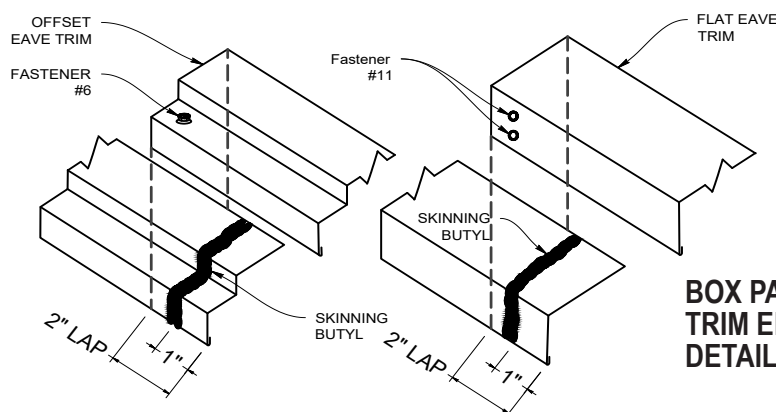

**BOX PANEL CAP TRIM END LAP DETAIL**

### HIGH SYSTEM EAVE WALL PANELS INSTALLED BEFORE ROOF

Install high eave plates flush with the outside face of the high crowns of the wall panels. Install Fastener # 1 in pre-punched slots (1' on center) of the eave plate. The first eave plate will butt against the rake support. All of the eave plates must be installed at this time.

Do not lap the eave plates! Butt them tight to each other at the ends. Place an 8" strip of Double Bead Tape Sealer at each end of the eave plate.

Install box panel cap trim to the top of the eave plate. Be sure to hold it tight to the wall panel face. Attach face of trim to panel and to eave plate with Fastener # 11 at 10' on center.

Install Double Bead Tape Sealer to top of eave plate flush with the down slope edge. If vinyl faced insulation is used apply double faced tape at the lower side of the eave plate.  
Wall Panels Installed After Roof.

### WALL PANELS INSTALLED AFTER ROOF

Install offset panel cap trim to the eave strut and wall panels with fastener #11 at 10' on center. Install Double Bead Tape Sealer under the eave plate on top of the cap trim.

Install high eave plates flush with the outside face of the high crowns of the wall panels. Install Fastener # 1 in pre-punched slots (1' on center) of the eave plate. The first eave plate will butt against the rake support. All of the eave plates must be installed at this time.

Do not lap the eave plates! Butt them tight to each other at the ends. Install Double Bead Tape Sealer on top of the eave plate flush with the outside edge.

Lap trim 2". Apply two beads of Skinning Butyl caulk 1" from trim end of bottom piece. Attach top piece to bottom piece with Fastener # 11.



## STEP 3

### THERMAL SPACER

(For High System Only)

Position the thermal spacer on top of the insulation over each purlin and against the rake support angle prior to installing the roof panel.

Using spray adhesive, (not by manufacturer), adhere the thermal spacer to the insulation (First Panel Run Only). The thermal spacer increases the insulation capacity along the purlins.

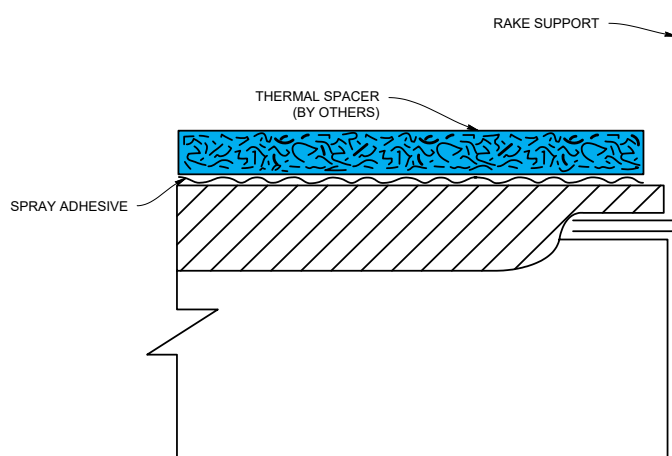
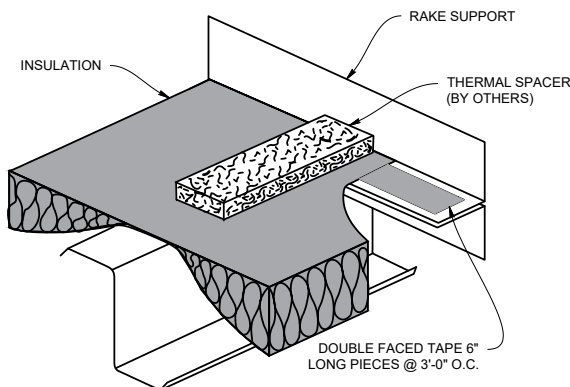
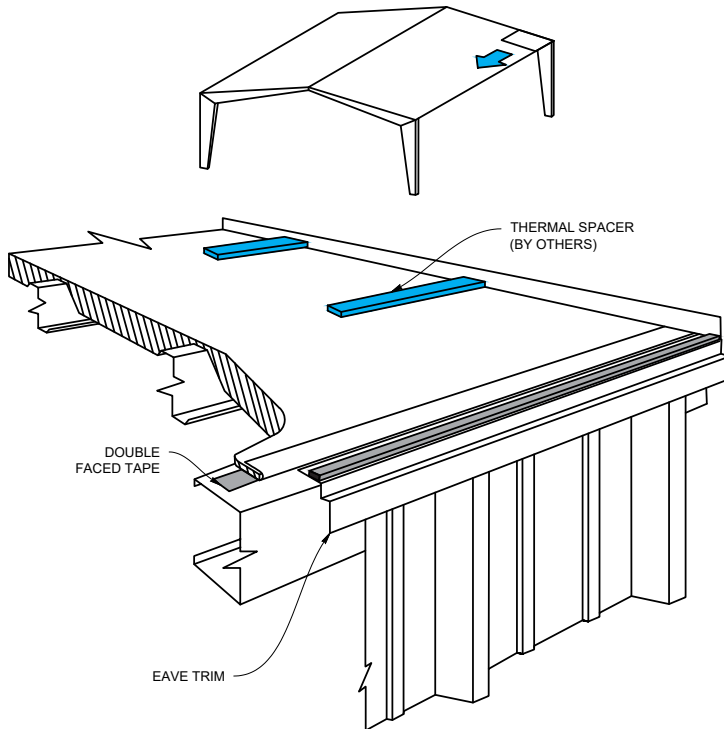

## STEP 4

### FIRST PANEL

Position the panel so that it overhangs the eave strut by the dimension shown on the Approval Drawings. The upper end of the panel must extend 7" beyond the web of the purlin if the panel covers eave to ridge. If more than one panel is required to cover eave to ridge, one or more end laps will be required. The upper end of the panel will extend 10" beyond the web of the purlin at end laps.

**NOTE:**  
If an end lap is required, then roof must be sheeted right to left as viewed from the eave looking toward the ridge.

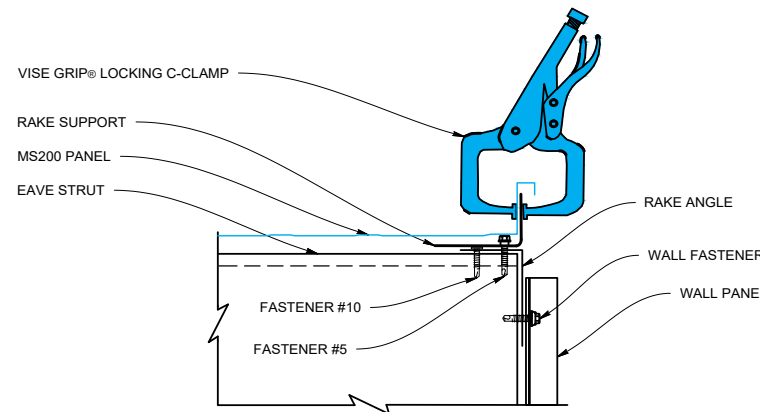
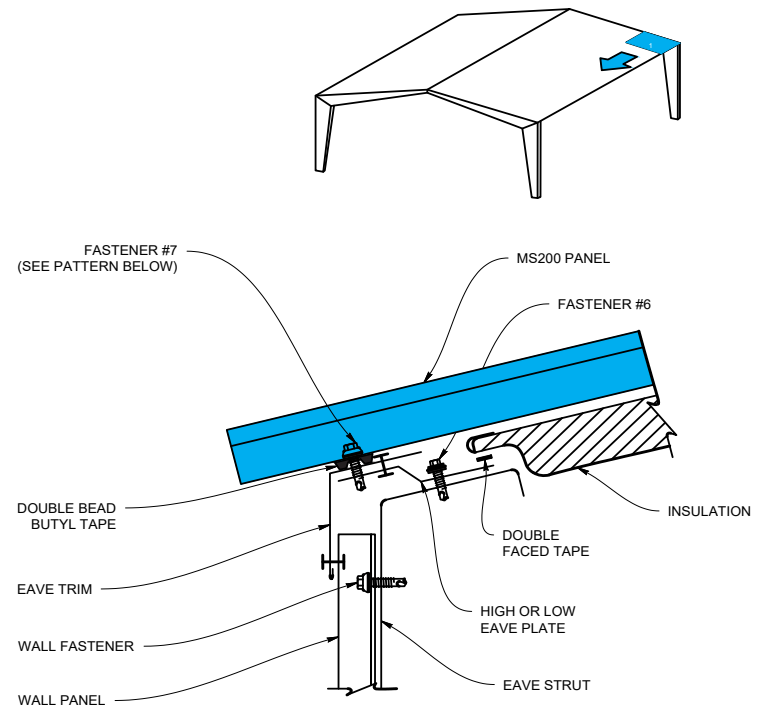

Lay the female leg of the panel over the rake support. To prevent wind damage, secure the female leg of the panel to the rake support with Vise Grip® Locking C-Clamps or temporary fasteners. Fasteners must go through the rake support. The panel will not be fastened permanently to the rake support until the rake trim is installed.

Attach the panel to the eave strut or eave plate with Fastener #7. Five fasteners are required at this location.

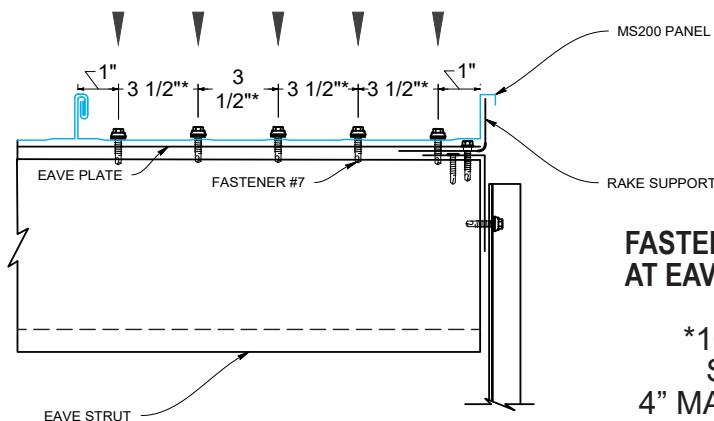

### FASTENING PATTERN AT EAVE

\*16" PANEL SHOWN  
4" MAX SPACING

## STEP 5

### CLIP INSTALLATION

Hook the panel clip onto male leg of panel. Hold end of clip up to keep it engaged onto male leg and rotate the clip base down to completely engage clip onto male leg. Install panel clips at each purlin.

Before fastening clip to purlins, check to ensure that vertical leg of clip is tight to the vertical leg of the panel. Failure to keep this leg tight to the panel leg will affect panel module.

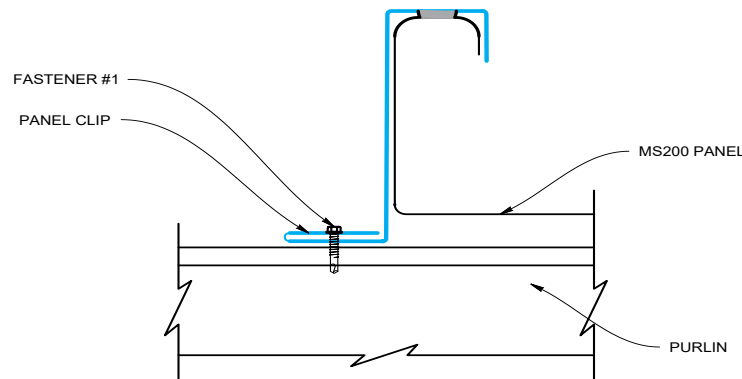
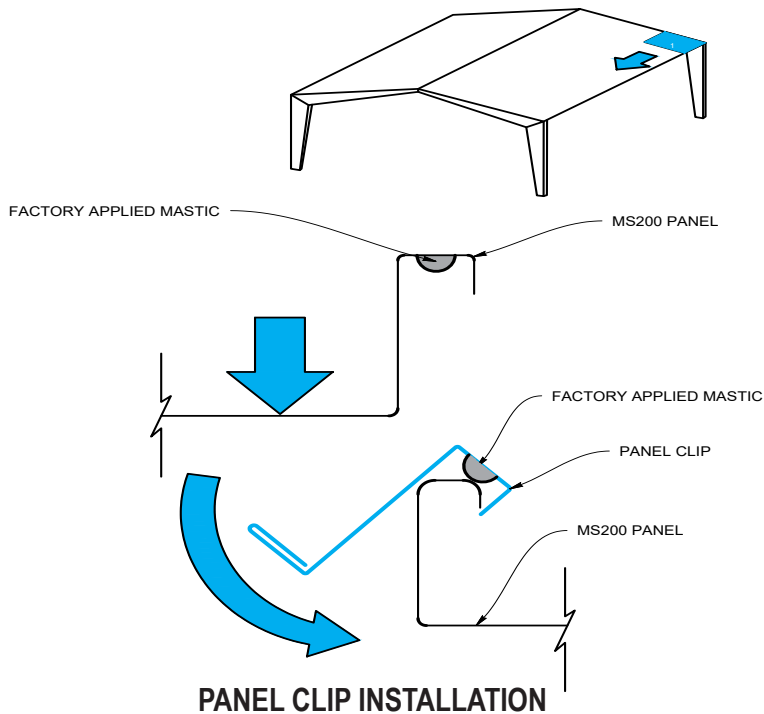

### RIGHT WAY

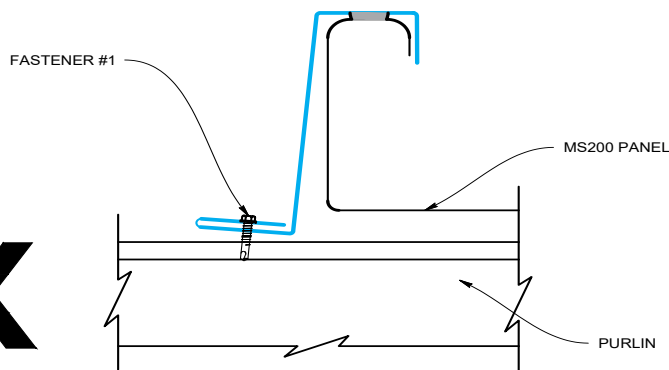

### WRONG WAY

#### CLIP FASTENER REQUIREMENTS

Purlins - Fastener #1 - Up to 4"  
Insulation Fastener #2 - Over 4"  
Insulation  
Bar Joists - Fastener #3 Up to 4"  
Insulation (Two Fasteners  
per clip)  
Fastener # 4 Over 4" Insulation  
(Two fasteners per clip)

#### CAUTION

The panel clip has factory applied mastic in the upper lip. This mastic is compressed when the clip is rotated in place. If, for some reason, a clip must be removed, a new clip must be used.

TMP highly recommends hand crimping (hand tool) the installed clip to the male panel rib BEFORE installing the next panel (female rib). This will prevent the male rib from disengaging from the clip in windy conditions or from foot traffic—prior to using a power seaming tool to fully form the seam.

## STEP 6

### RIDGE

At the ridge, the panel should extend 7" past the web of the peak purlin.  
At the ridge install a back-up plate as outlined in Step 5.  
Install clips as outlined in Step 4  
Seal the male ribs, 12" from the end, with skinning butyl caulk.

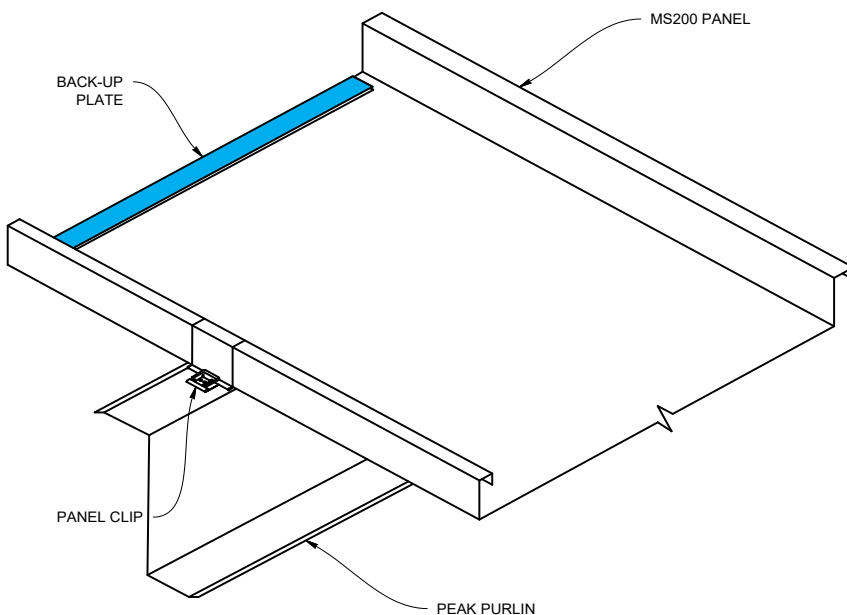
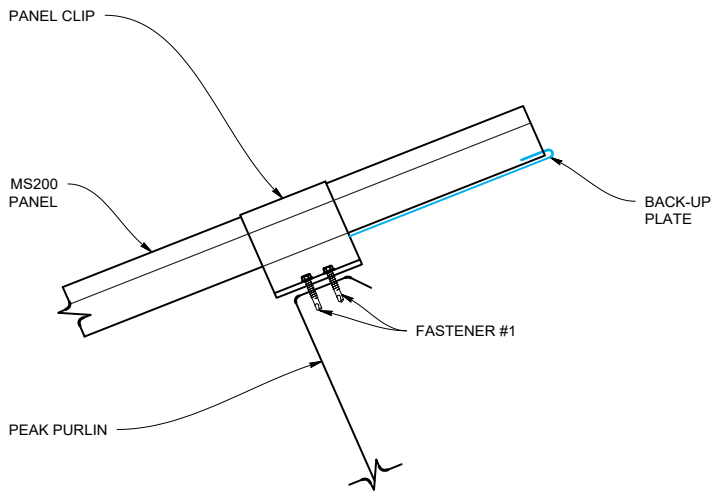
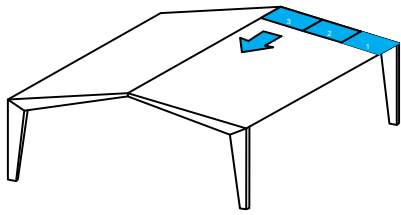

## STEP 7

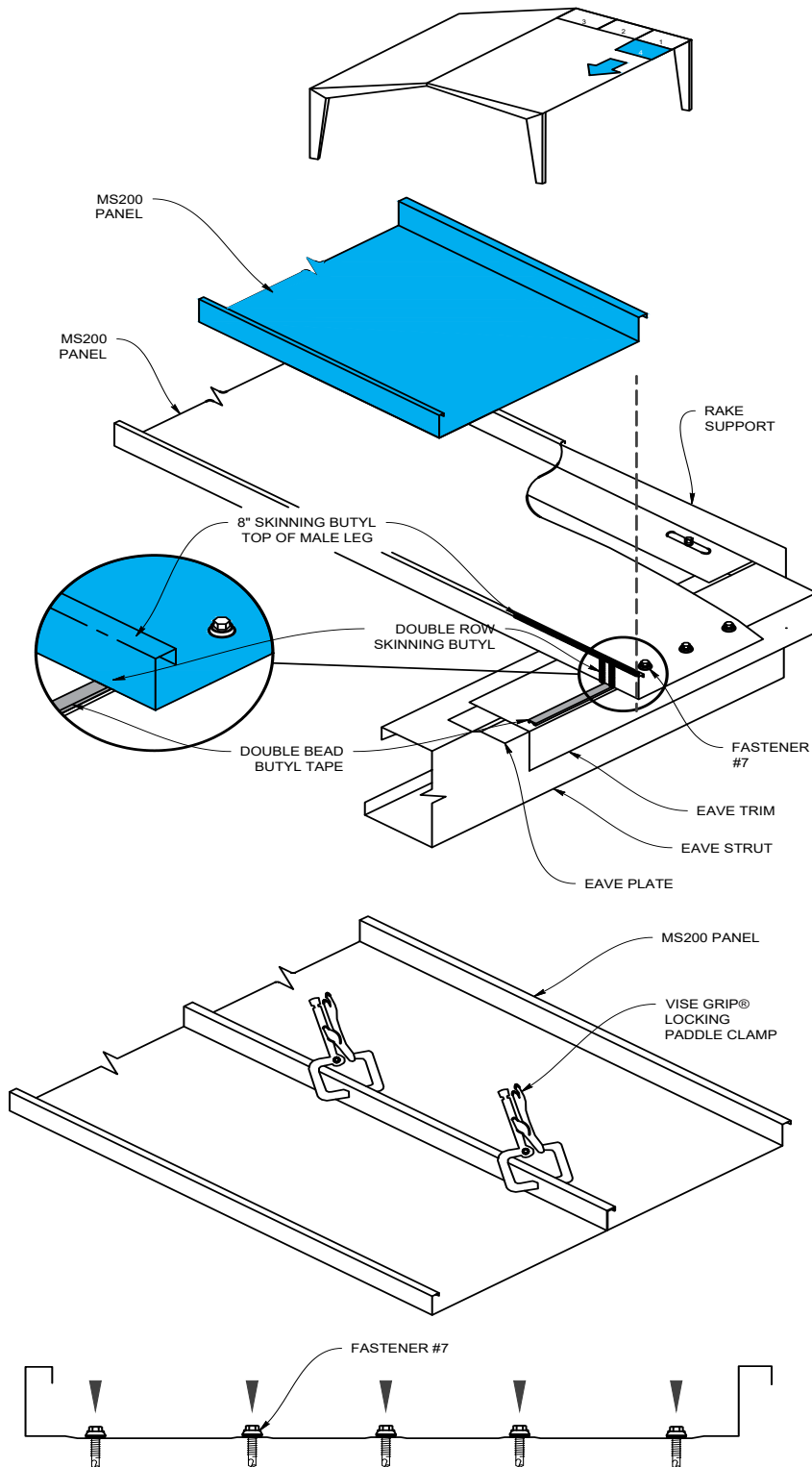

### SUBSEQUENT RUNS EAVE

Apply skinning butyl to the male leg of the first panel directly over the Triple Bead tape sealer at the eave. This will prevent water infiltration through the end of the panel seam.

Position the next panel with the female leg over the male leg of the previous panel with panel ends flush.

Clamp the panel seam together at both ends. Long panels may require one or more paddle clamps in the middle. This will help hold panel module and assist with proper sealing.

Install fasteners at eave as outlined in Step 3.

Install clips as outlined in Step 4.  
Crimp panel seam at all clip locations with hand crimping tool. Panels should be fully seamed with electric seamer as quickly as possible after a section of the roof is completed.

#### CAUTION

Panel must be crimped at all clip locations as they are installed to provide temporary wind resistance.

## STEP 8

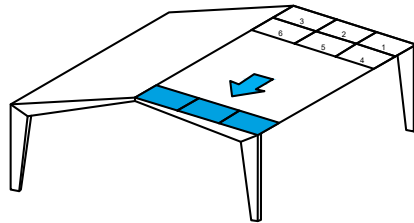

### LAST PANEL RUNS

Install rake support at the finishing end of the roof as outlined in Step 1

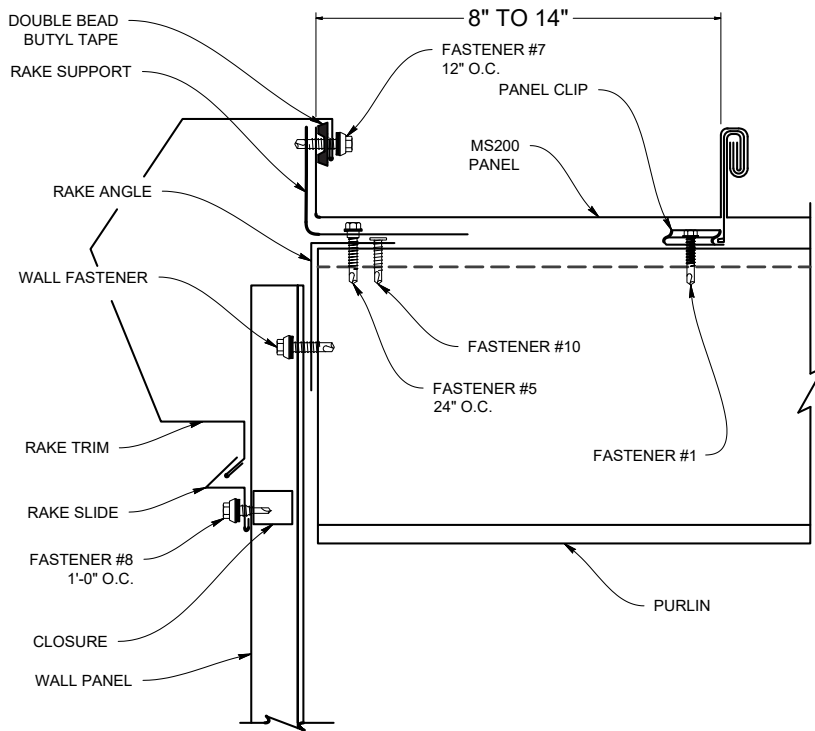

### FINISHING DIMENSION RUN OF 8" TO 14"

Field cut and bend a 2" tall vertical leg on the panels in the last run of roof. The vertical leg must be tight to the rake support angle. Secure the vertical angle to the rake support angle with clamps or temporary fasteners. At the end lap and ridge, a partial back-up plate must be cut.

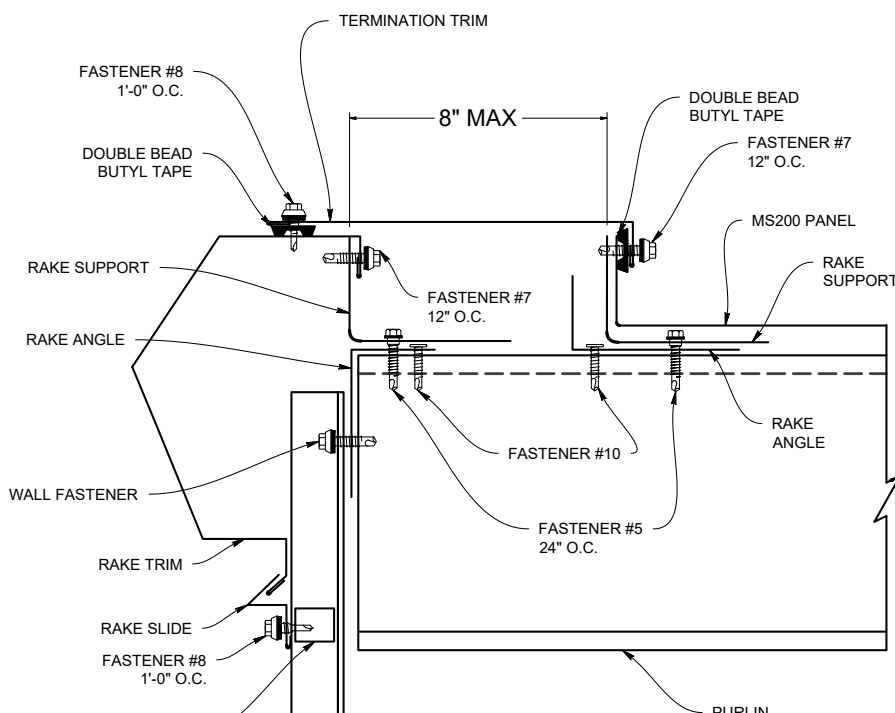

### FINISHING DIMENSION RUN OF LESS THAN 8"

If the width of the last panel run is 8" or less, a second run of rake support angle must be installed for attachment of the vertical leg of the panel. A variable termination trim will be required to seal the gap between the vertical leg of the panel and the rake trim. The male leg of the panel and the termination trim must be field cut to fit the condition.

## STEP 9

Only DI Seamers are authorized to properly seam MS-200™ panels from Taylor Metal Products. Follow all instructions with the DI seamer to assure proper roll forming of the MS-200™ panels.

### SEAMING OPERATION

Contact DI Seamers at:  
915 US-45  
Corinth, MS 38834  
(888)-343-0456  
(662)-287-6626

Home: <http://www.diroofseamers.com/home.html>

Field Guide: <http://www.diroofseamers.com/fieldguide.html>

Rentals: <http://diroofseamers.com/options.html>

## STEP 10

### END DAM INSTALLATION

Panels must be hand folded flat (90°) for 3" with a hand tool to allow the outside closure to be installed. Place Double Bead tape sealer across full width of panels, including under panel seams at ridge. Center of tape sealer should be 1 1/2" from end of panels.

**NOTE:** End Dams are formed directional (Left to Right or Right to Left) Be sure to specify quantities of both options.

It is important that the closures fit tight to the panel seams to prevent the need for excess butyl caulk at this location.

Install end dam by rotating the end cut for the panel seam into place first. Then rotate the other end of the outside closure into place. The vertical leg of the end dam should be 2" from the upslope end of the panel. Attach the outside closure to the panel with Fastener #1 at each specified location. Before installing the next end dam, install a piece of Double Bead tape sealer onto the top flange of the end dam previously installed. This is to prevent water being blown between the end dam where the top flanges overlap. After all end dams are in place, install Double Bead tape sealer across the top flange.

Use skinning butyl sealant to fill any voids around the panel seams on the upslope side of the end dams.

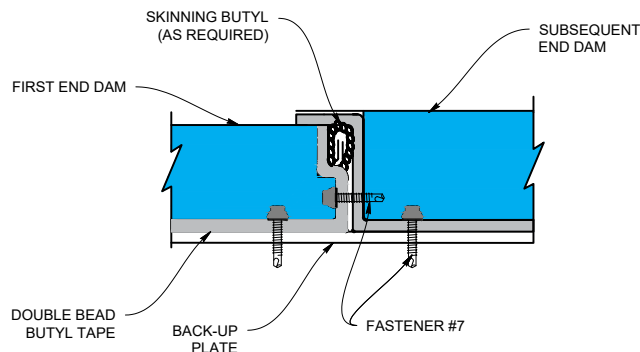
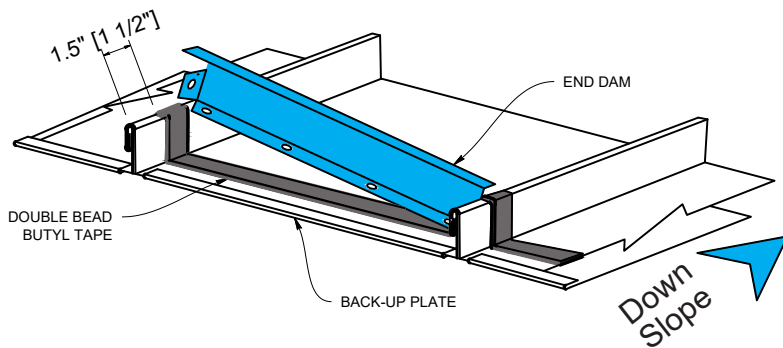
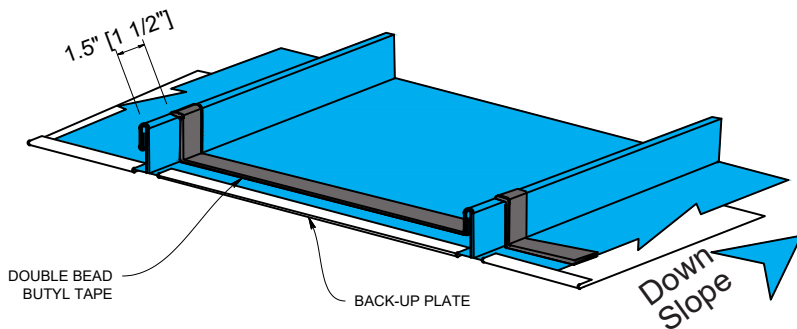



## PIPE PENETRATION INSTALLATION

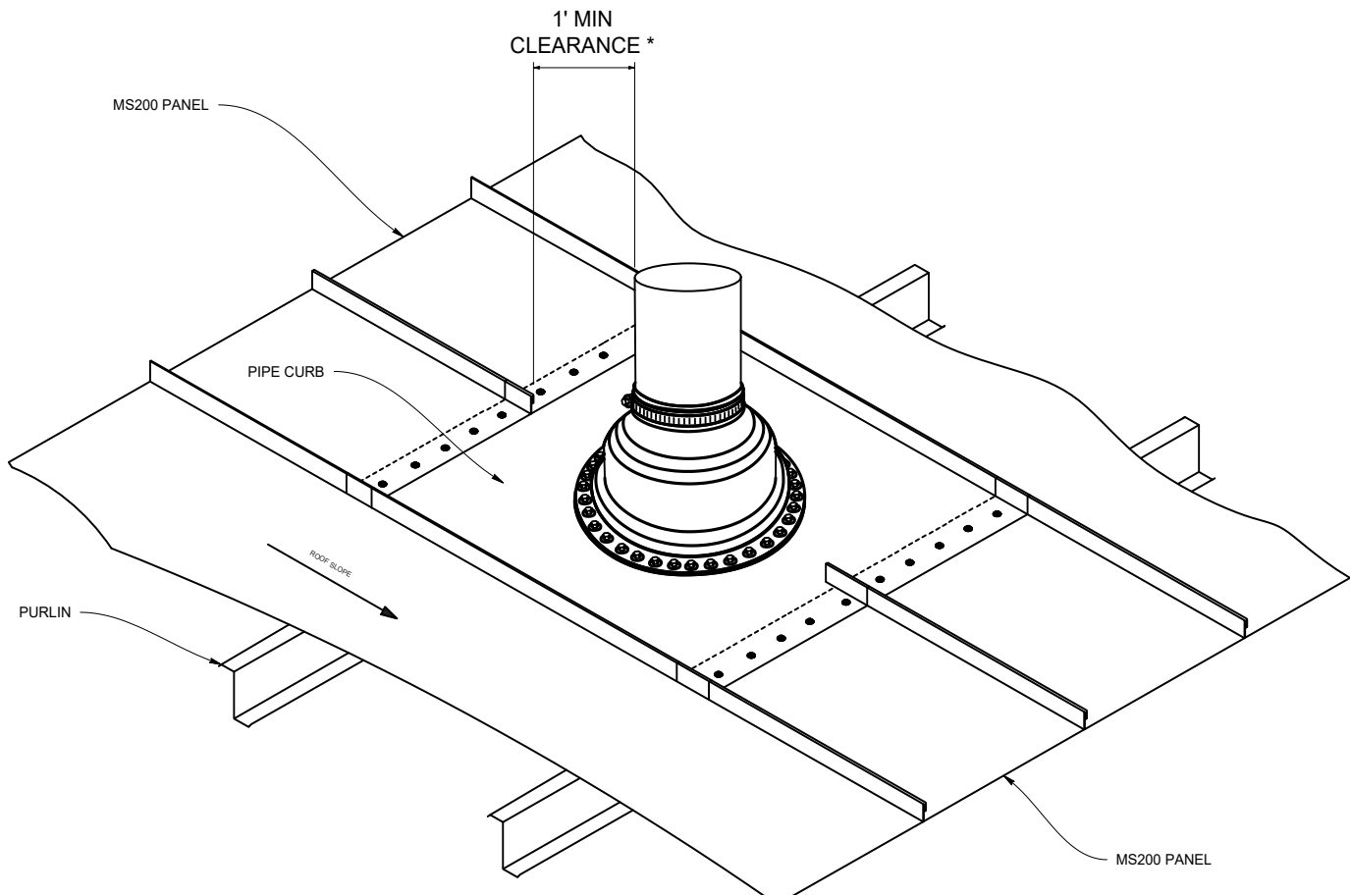

### Recommended Large Pipe Penetration Installation

This method to be used in all locations where a pipe penetration intersects a panel rib or when the pipe is too large and will not allow adequate drainage down the panel.

\* 1' MINIMUM CLEARANCE FROM CUT  
EDGE OF PANEL TO EDGE OF PIPE.

## PIPE PENETRATION INSTALLATION

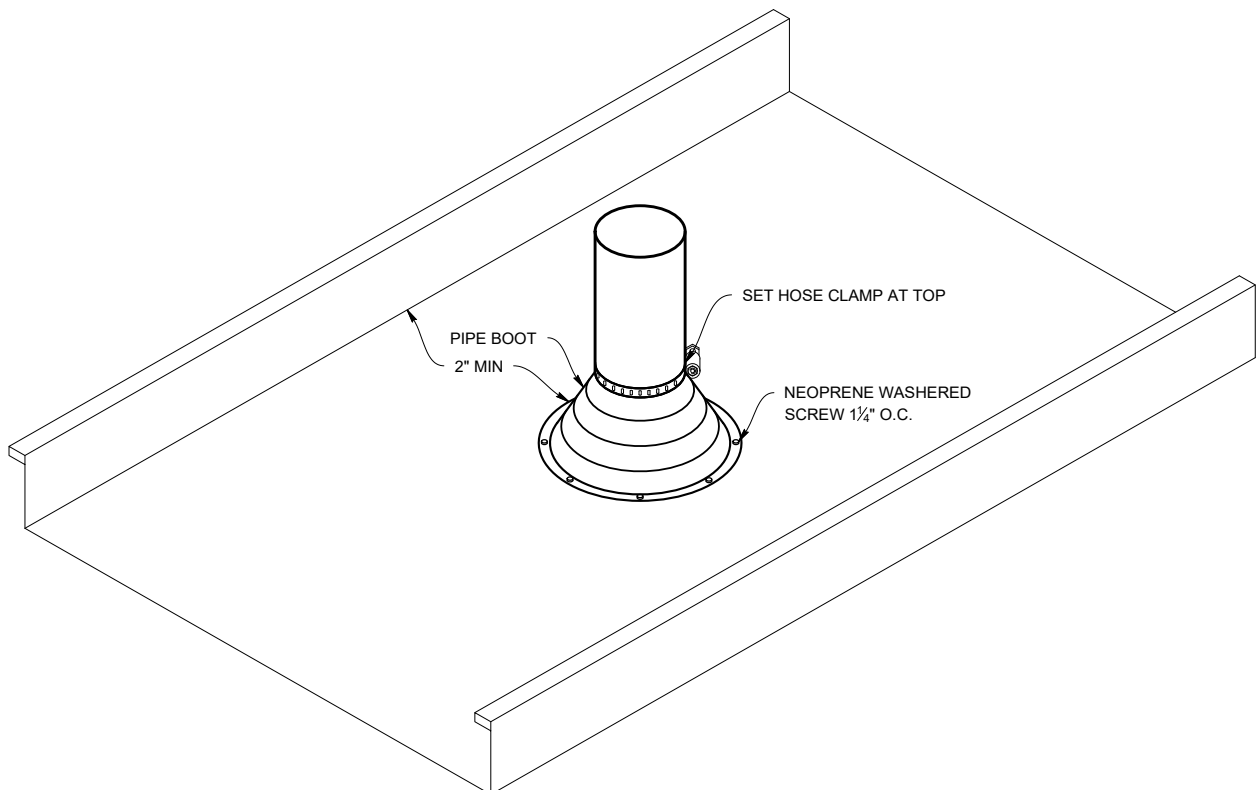
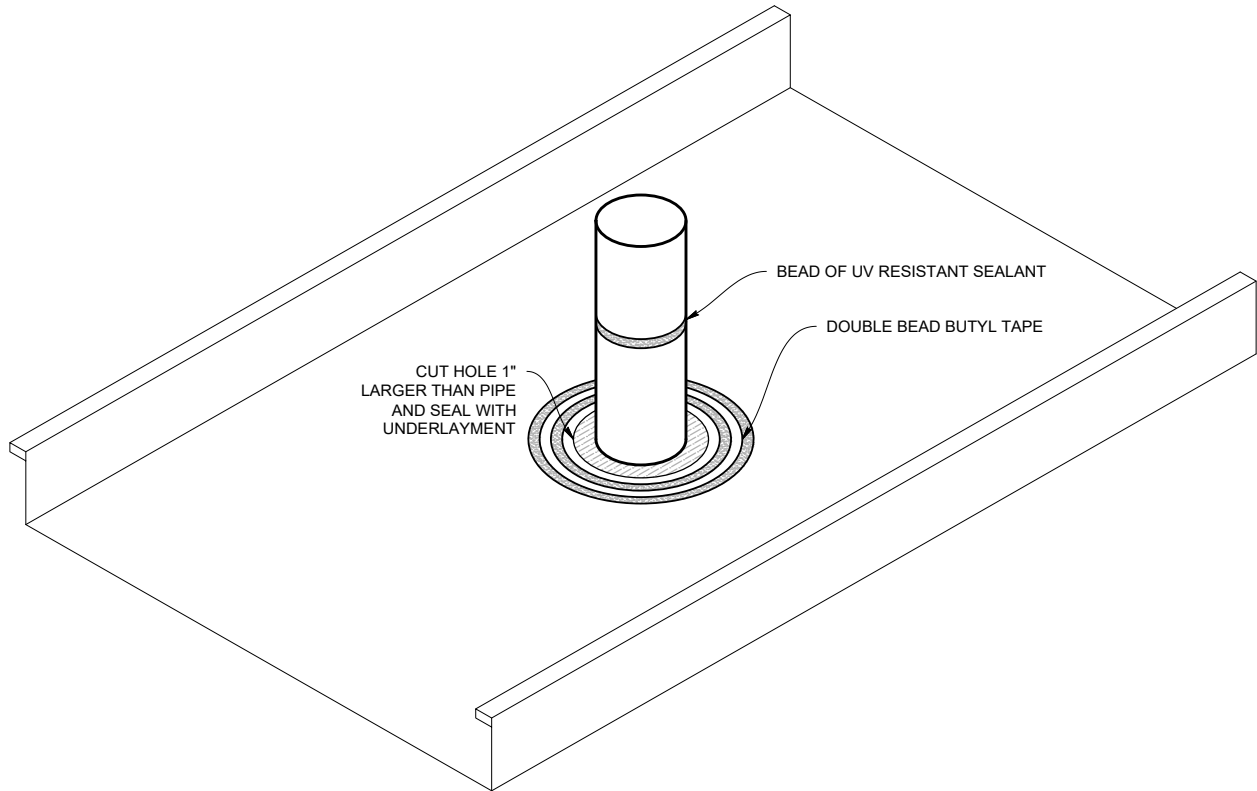

## PIPE PENETRATION HOME PLATE PIPE PENETRATION

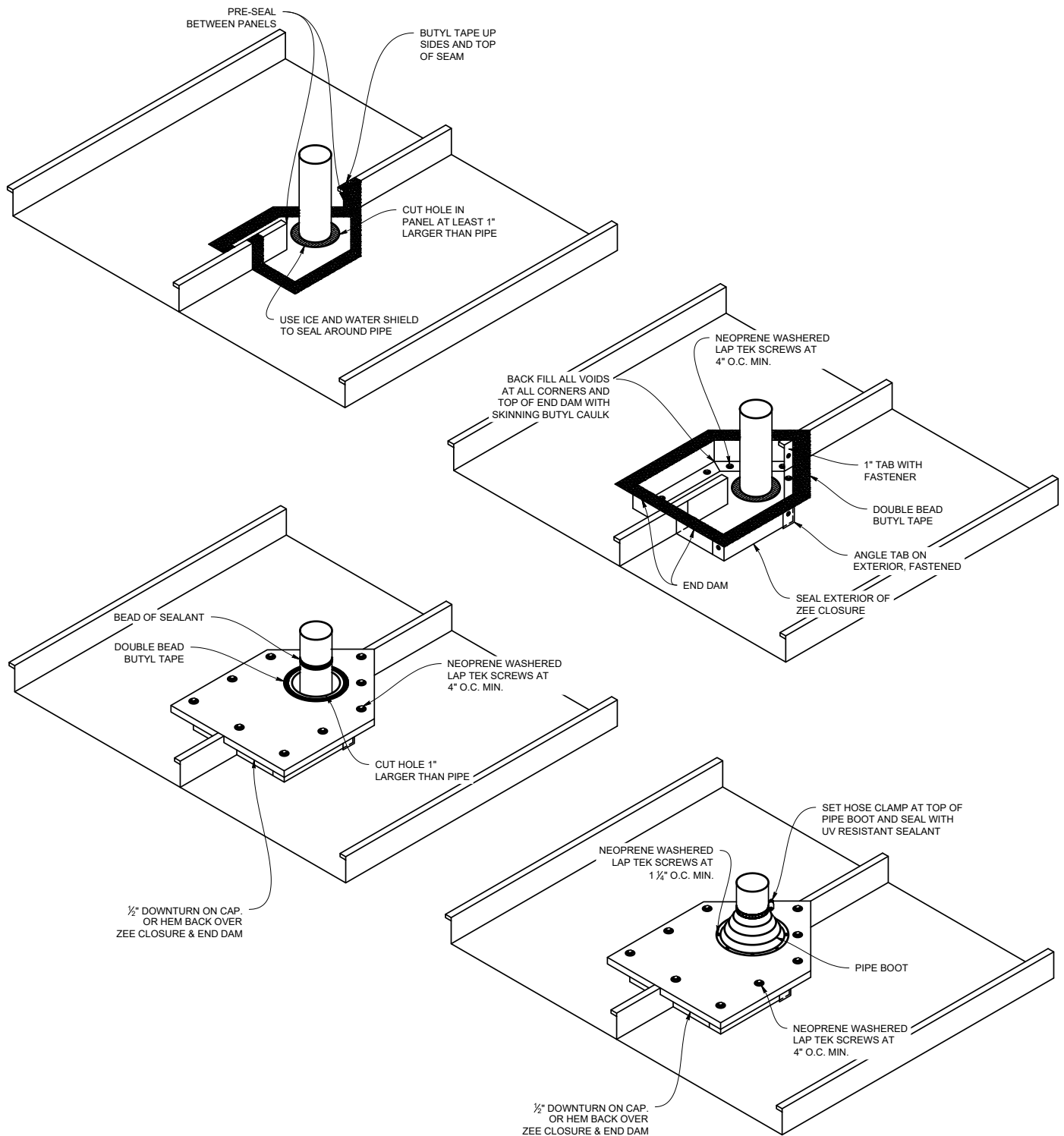

## OPEN FRAMING FIXED EAVE WITH HANG ON GUTTERS

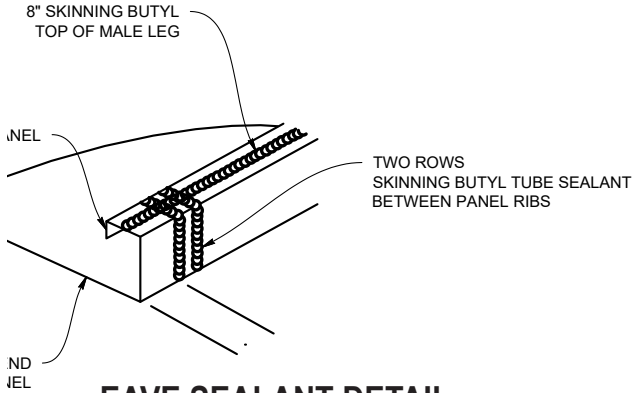

**EAVE SEALANT DETAIL**  
 SKINNING BUTYL  
 SEALANT MUST BE IN  
 CONTACT WITH BUTYL  
 ON TOP OF MALE LEG TO  
 FORM A WEATHERTIGHT  
 SEAL.

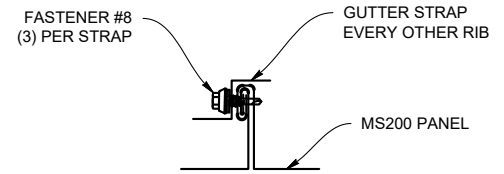

**GUTTER STRAP ATTACHMENT**

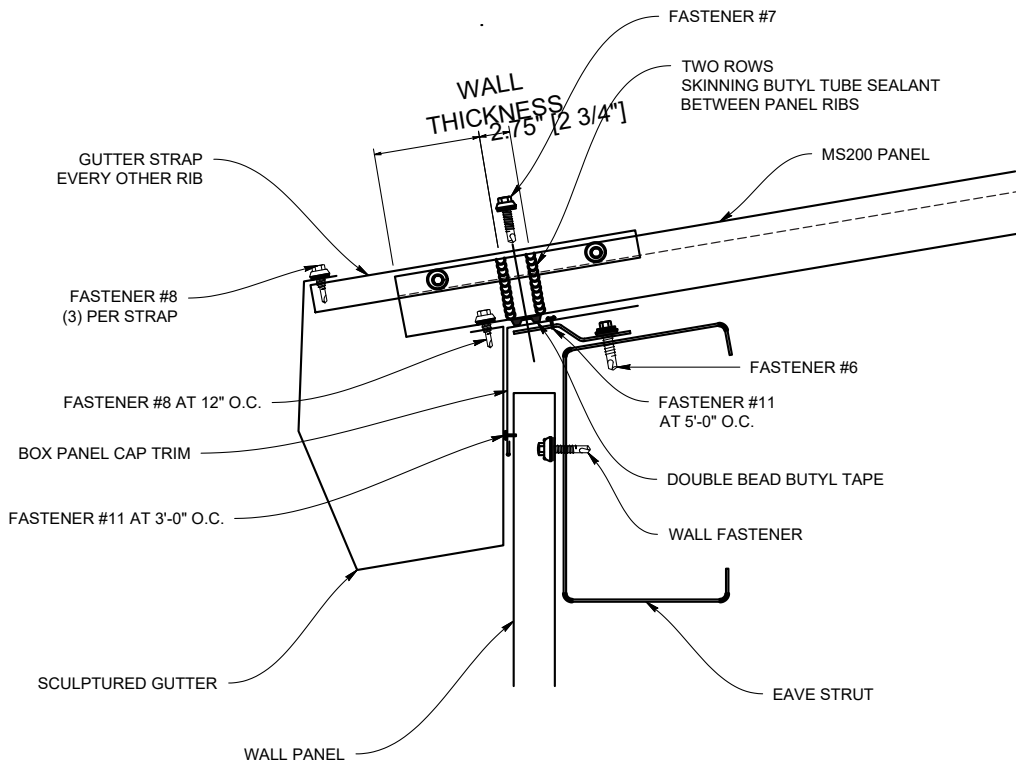

**OPEN FRAMING  
FIXED EAVE WITH EAVE TRIM**

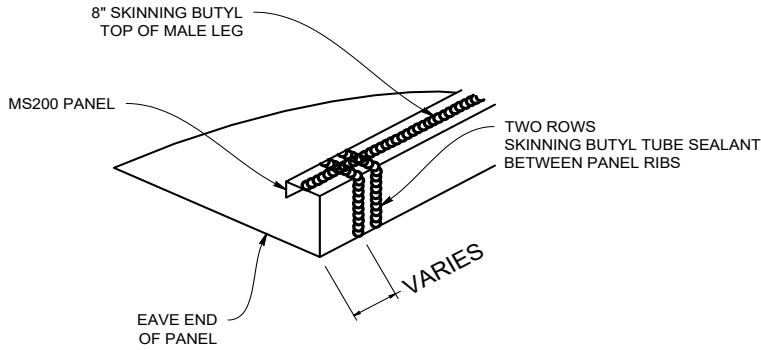

**EAVE SEALANT DETAIL**  
*SKINNING BUTYL  
SEALANT MUST BE IN  
CONTACT WITH BUTYL  
ON TOP OF MALE LEG TO  
FORM A WEATHERTIGHT  
SEAL.*

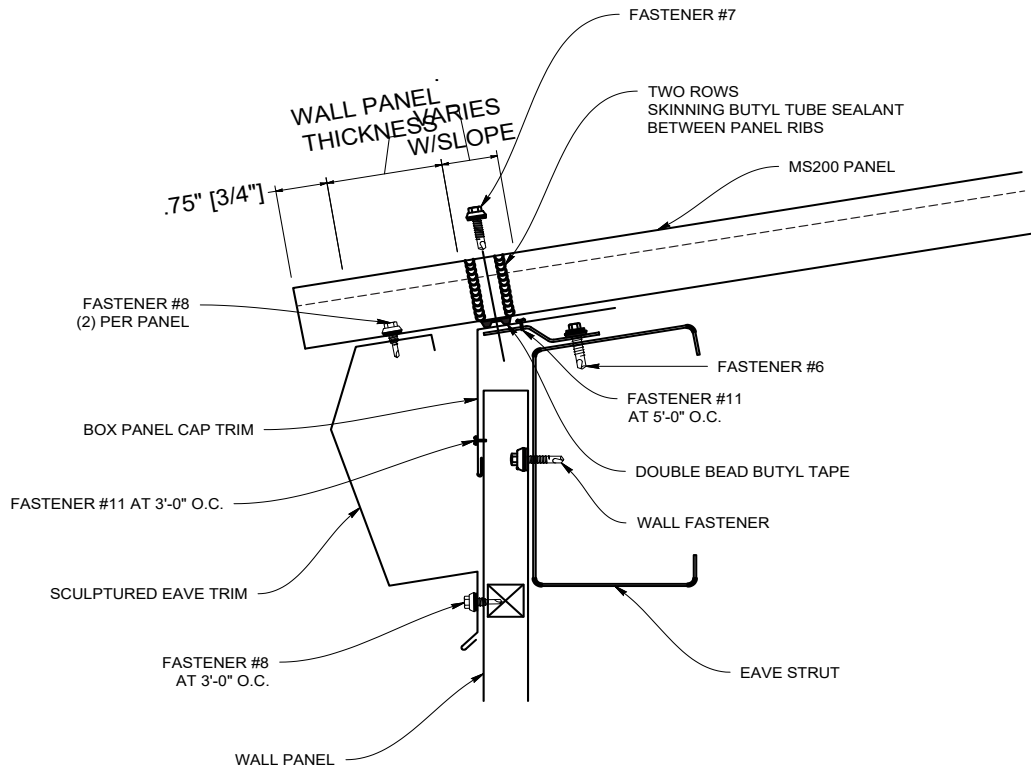

## OPEN FRAMING FLOATING RIDGE

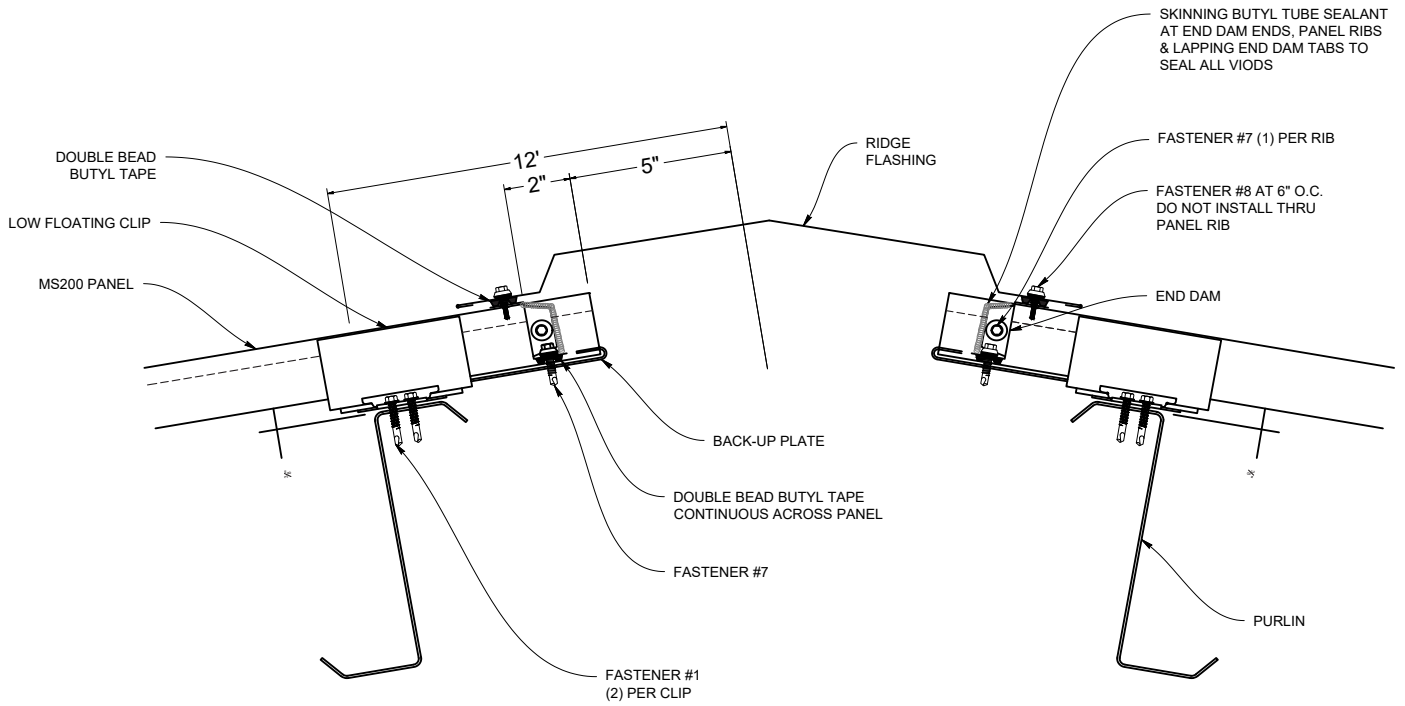

**OPEN FRAMING  
FLOATING VENT RIDGE**

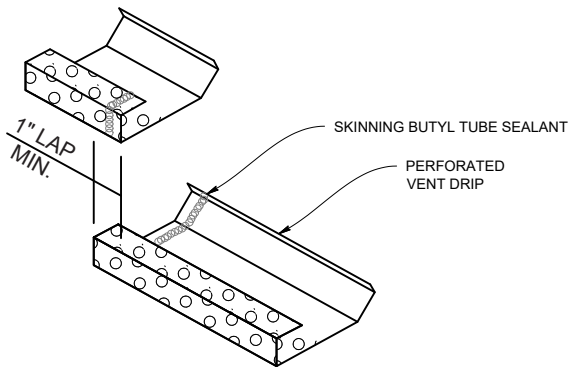

**PERFORATED VENT DRIP END**

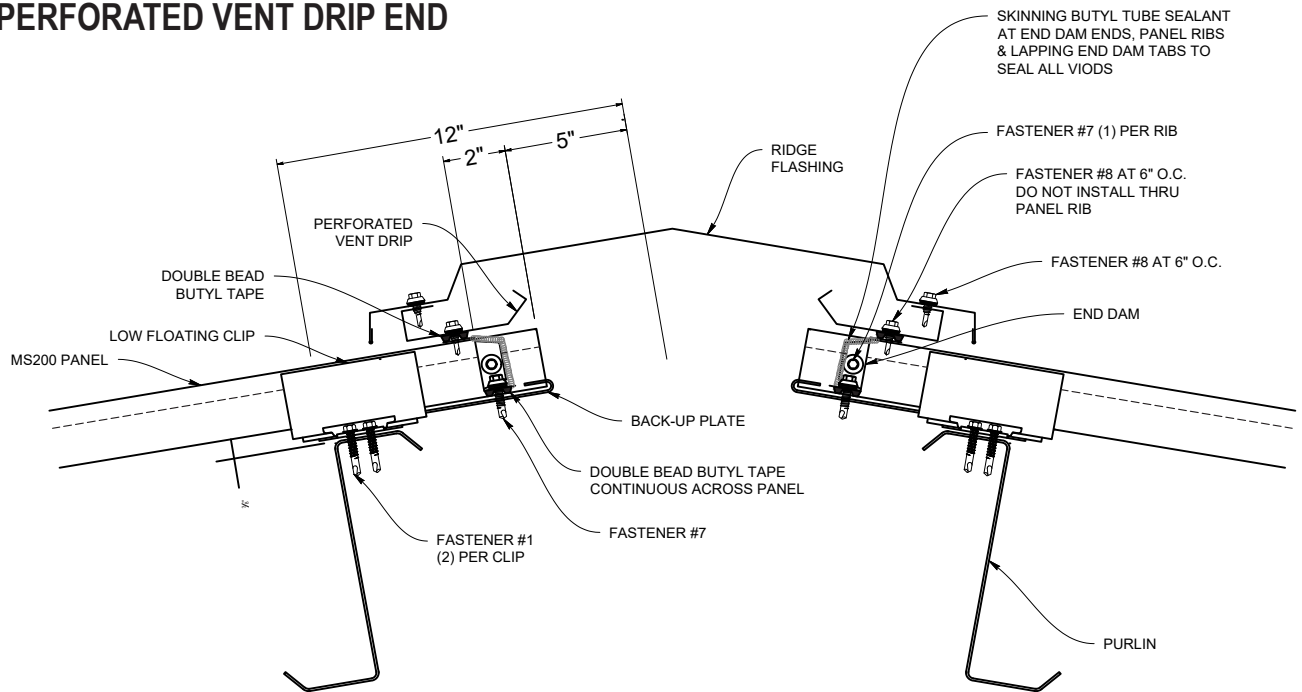

## OPEN FRAMING RAKE

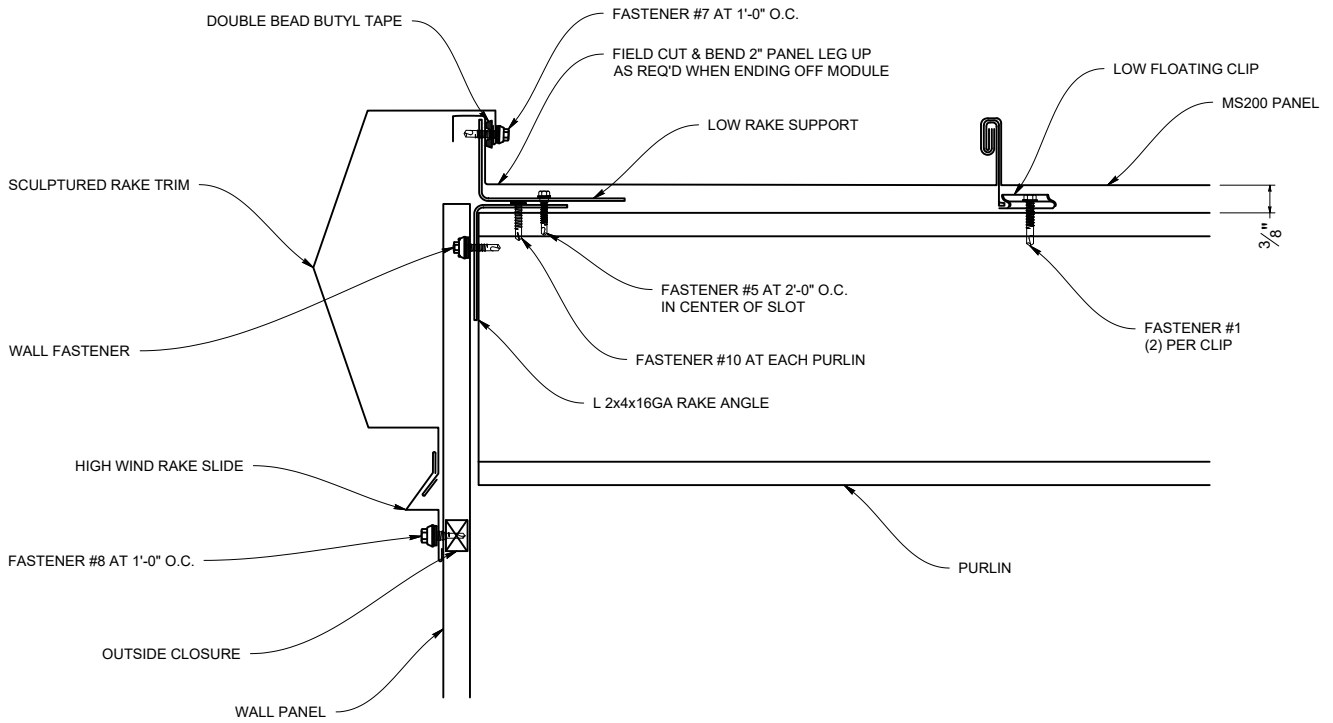



**OPEN FRAMING  
RAKE WITH CLEAT**

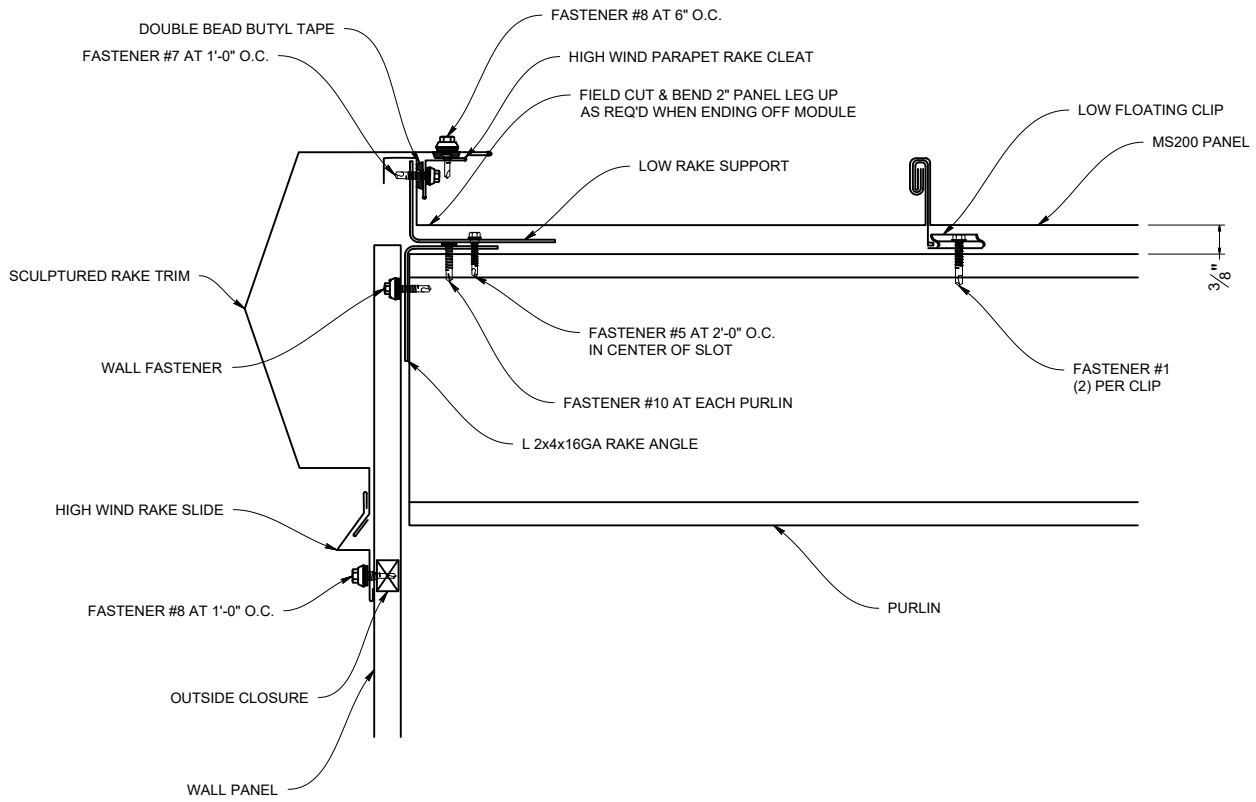

## OPEN FRAMING PARAPET RAKE

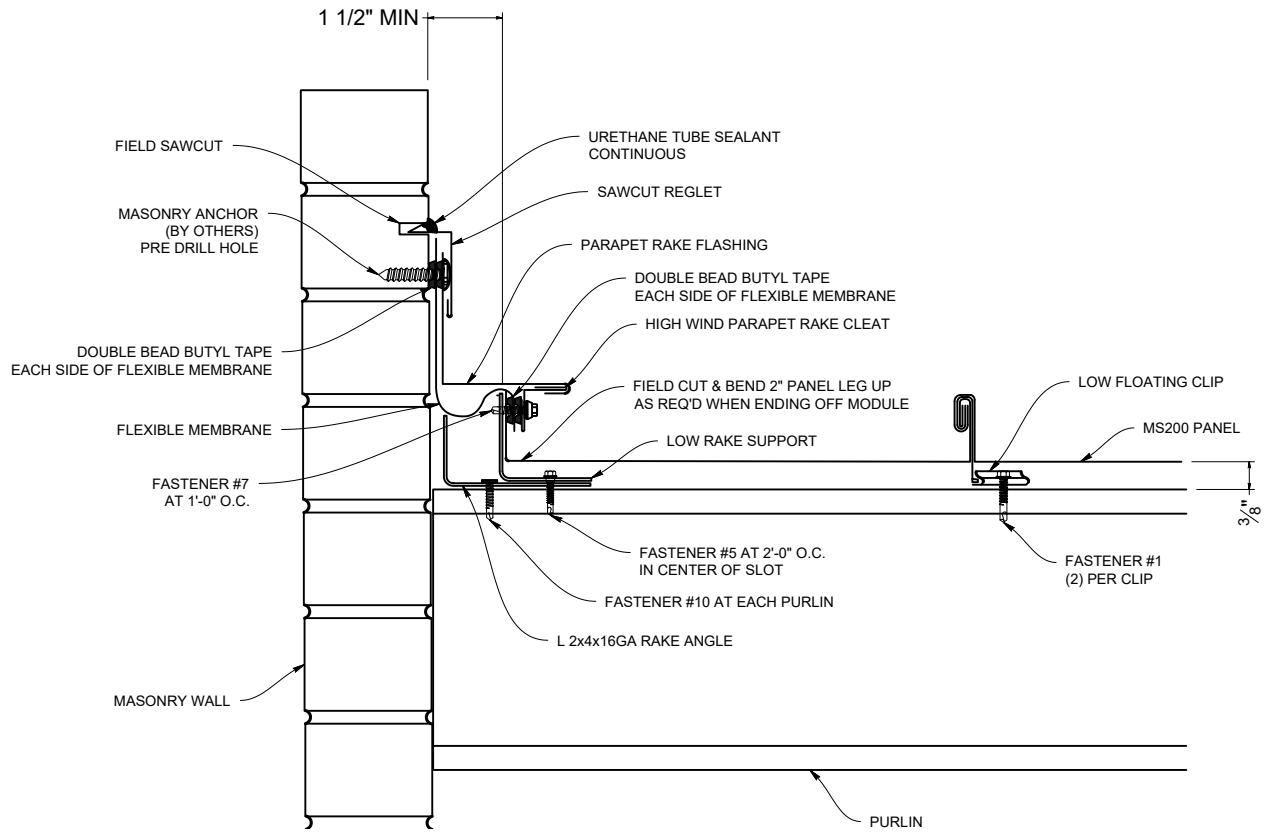

**OPEN FRAMING  
FLOATING HIGH SIDE EAVES**

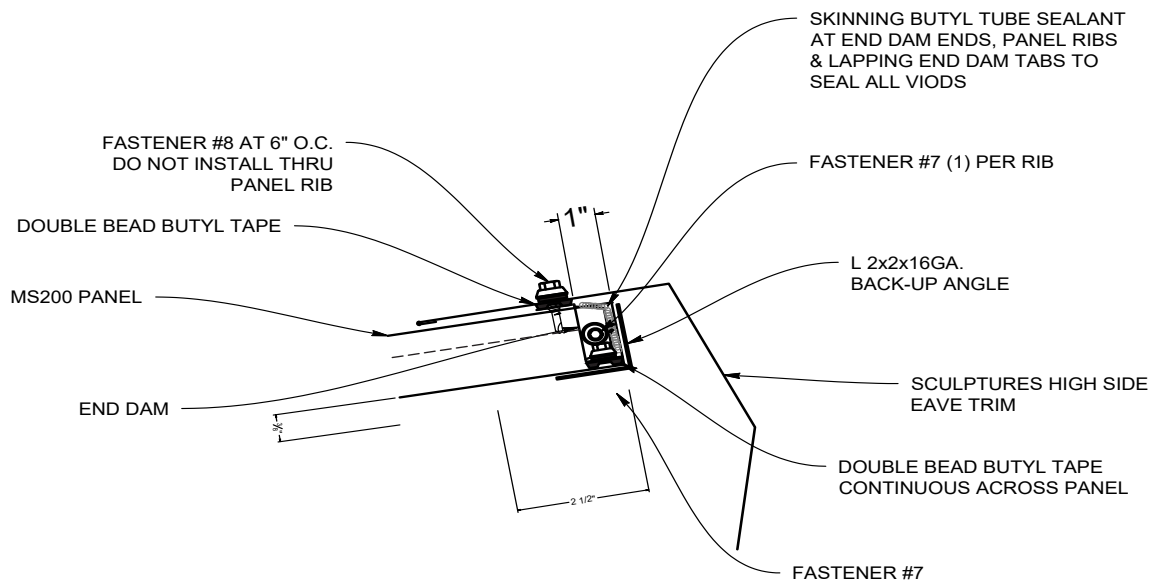
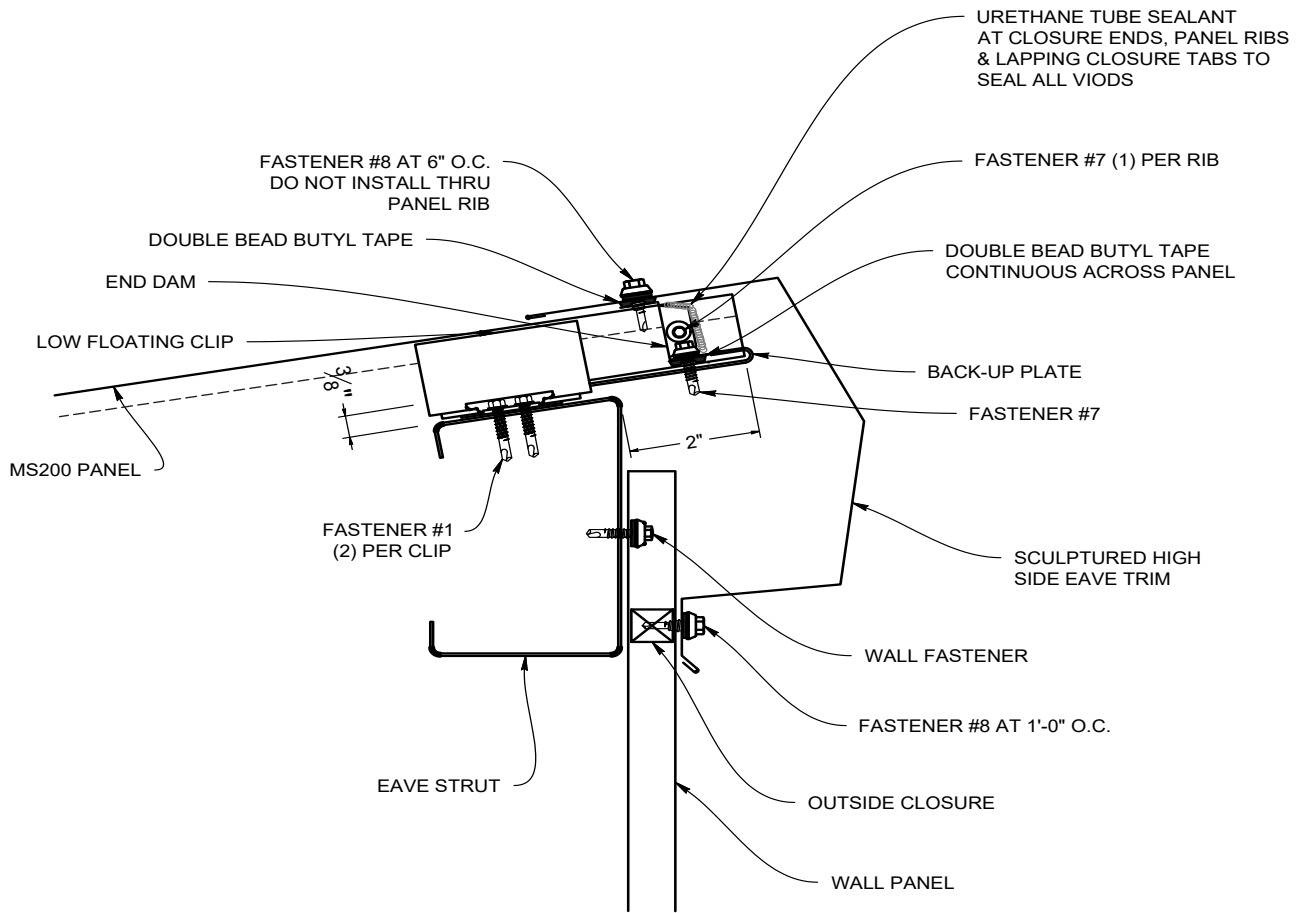

## OPEN FRAMING PARAPET FLOATING HIGH SIDE EAVE

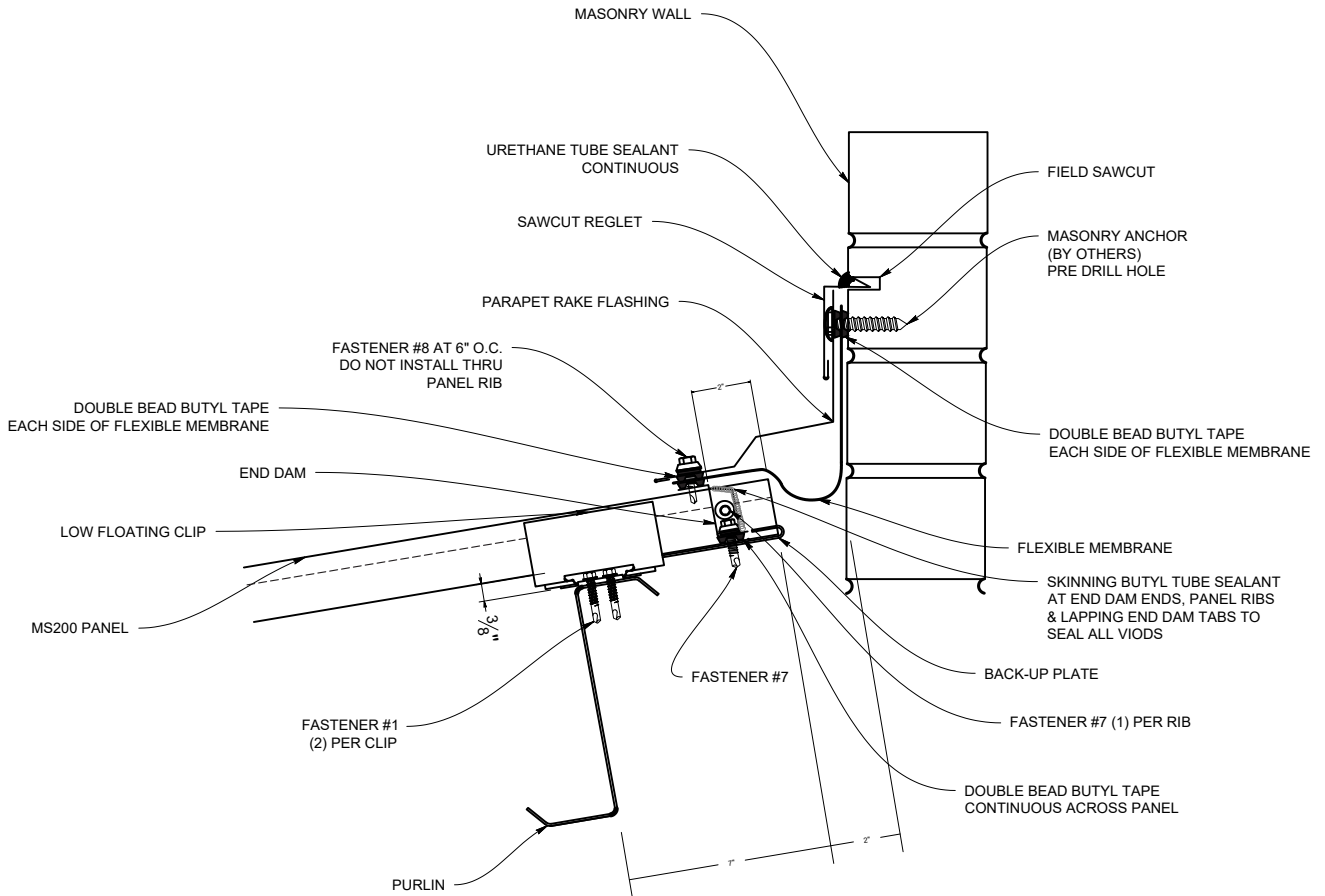

Customer Name: \_\_\_\_\_ Job Name: \_\_\_\_\_

Gauge: \_\_\_\_\_ Color: \_\_\_\_\_

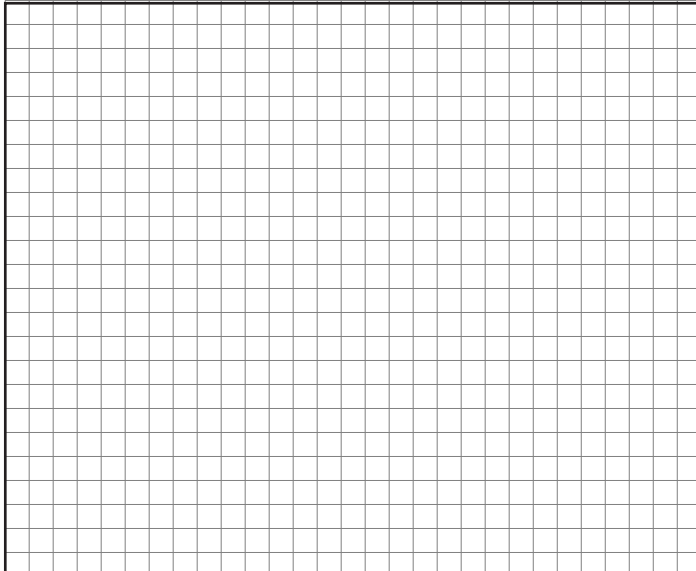
		
Dwg #:	Pitch:	# of Pieces:
Description: _____		
Hems: <input type="checkbox"/> Open <input type="checkbox"/> Closed <input type="checkbox"/> Slightly Open		

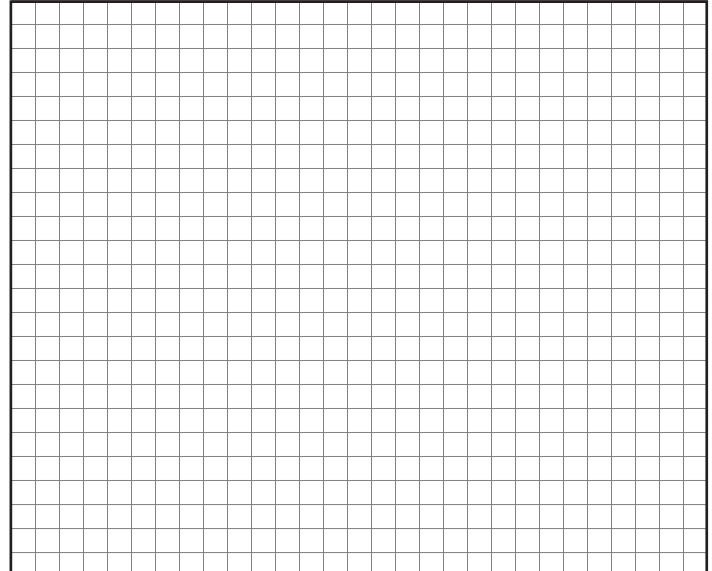
		
Dwg #:	Pitch:	# of Pieces:
Description: _____		
Hems: <input type="checkbox"/> Open <input type="checkbox"/> Closed <input type="checkbox"/> Slightly Open		

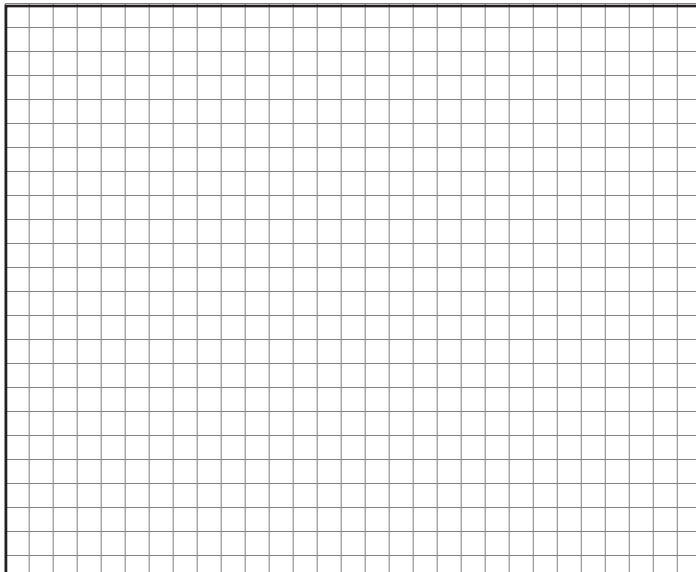
		
Dwg #:	Pitch:	# of Pieces:
Description: _____		
Hems: <input type="checkbox"/> Open <input type="checkbox"/> Closed <input type="checkbox"/> Slightly Open		

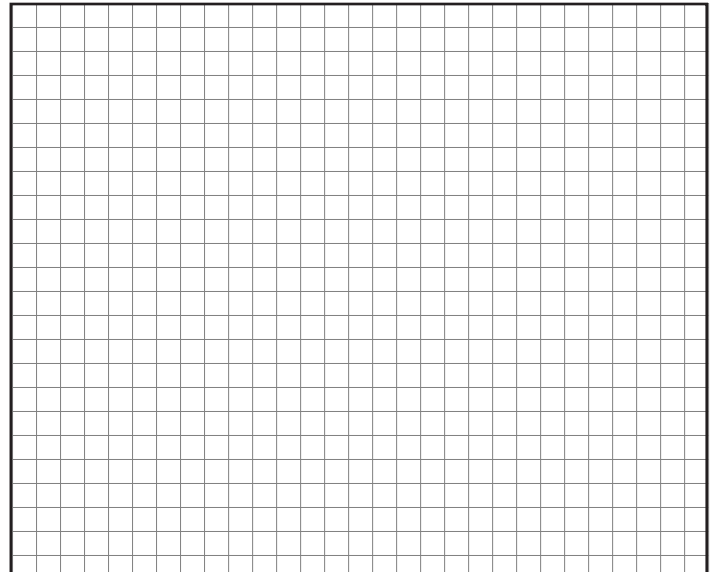
		
Dwg #:	Pitch:	# of Pieces:
Description: _____		
Hems: <input type="checkbox"/> Open <input type="checkbox"/> Closed <input type="checkbox"/> Slightly Open		

**Please provide a drawing for each flashing with precise measurements and angles**  
**Fax to: 503-581-6877**







---

**METAL PRODUCTS**

---

**QUALITY PRODUCTS  
EXCEPTIONAL SERVICE**

---

**SALEM BRANCH**

4566 Ridge Dr. NE  
Salem, OR 97301

Office: 503-581-8338  
Toll Free: 1-800-574-1388  
Fax: 503-581-6877

**SACRAMENTO BRANCH**

5711 Perrin Ave  
McClellan, CA 95652

Office: 916-318-8844  
Toll Free: 1-800-574-1388  
Fax: 916-993-4123

**WOODINVILLE BRANCH**

5927 234th St. SE  
Woodinville, WA 98072

Office: 425-485-3003  
Toll Free: 855-334-8558  
Fax: 425-485-2710

**AUBURN BRANCH**

710 A. St. NW Suite 101  
Auburn, WA 98002

Office: 206-900-9923  
Toll Free: 1-800-574-1388  
Fax: 253-804-3545

**RIVERSIDE BRANCH**

4880 Felspar St.  
Riverside, CA 92509

Office: 323-407-7457  
Toll Free: 1-877-504-1594