



Versa-Span™ Installation Guide - WeatherTight Warranty Details

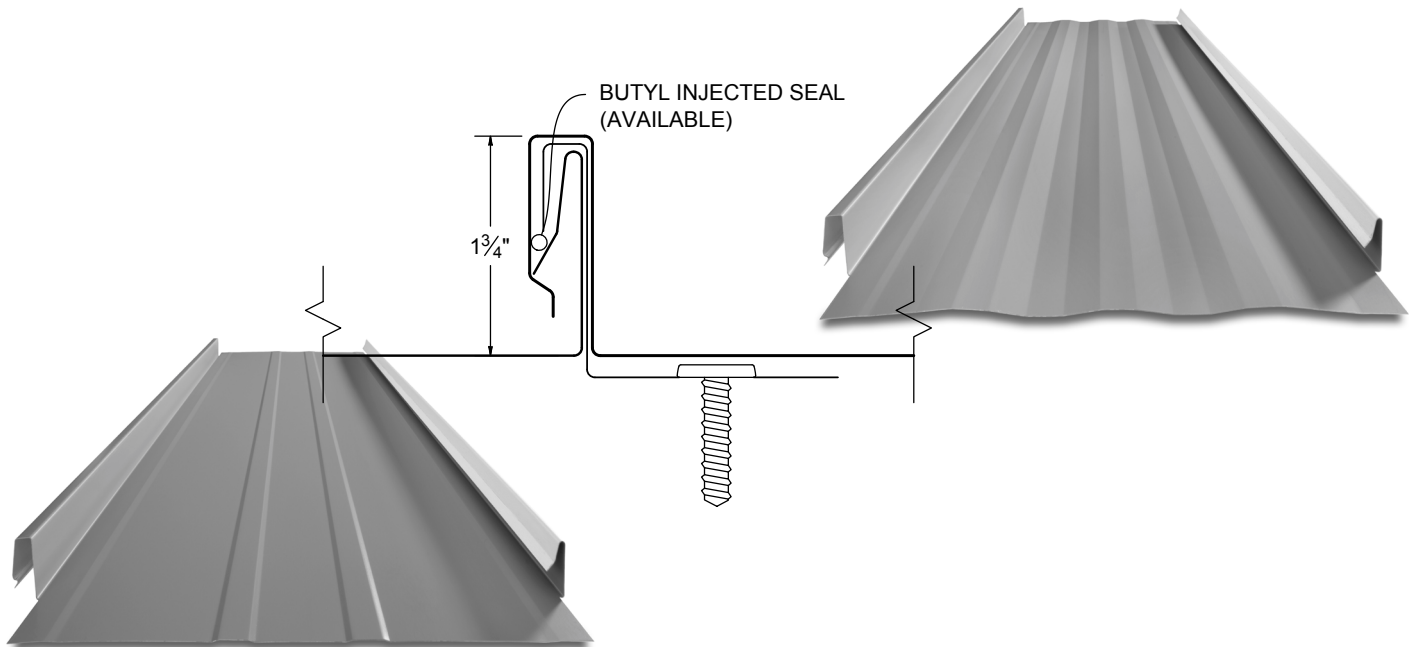



Table of Contents

Panel Specifications	2-3
Taylor Delivery Fleet	4
Delivery, Will Call & Loading	5
Notes To Designer/Installer	6-8
Standard Eave	9
Hook Eave	10
Gutter / Hook Eave	11
Standard Ridge	12
Ridge Full Vented	13
End Dam Attachment	14
Valley	15
Valley – Low Slope	16
Standard Gable	17
Alternate Gable	18
Sidewall	19
Peak Flashing (R.E.C.)	20
Vented Peak Flashing (R.E.C.)	21
Pitch Change	22
Endwall	23
Vented Endwall	24
Saw Cut Endwall	25
Curb Back Pan / Cricket Isometric Details	26-28
Curb Sidewall	29
Curb Endwall	30
Curb/Pan Cricket	31
Eave to Gable Transition	32-34
Pipe Penetration – on Plate	35
Pipe Penetration – on Rib	36-37
Pipe Penetration – on Pan	38
Flashing Selection	39-42



KEY FEATURES

- 12", 14", 16" & 18" coverage options
- 24, 22 gauge Tru-Gauge™ and .032" Aluminum
- Floating clip system: allows for expansion/contraction of panels in longer lengths
- 1-3/4" vertical rib, factory notching available
- Factory injected Butyl sealant available with testing
- Structural panel that will span up to 4'
- Concealed fasteners: fasteners cannot leak
- Manufactured in Sacramento, CA & Salem, OR
-  - Code compliance UL Evaluation Report UL ER 25913-01
- UL 580 Class 90 Wind Uplift rated, UL 790 Class A Fire rated and UL 2218 Class 4 Impact (hail) rated
- UL Construction No. 254, 255, 261, 303, 342, 343, 414, 436, 445, 447, 448, 486, 508, 508A, 543, & 544
- ASTM E283 - Air infiltration (walls)
ASTM E331 - Water infiltration (walls)
ASTM E1592-Structural uniform static air pressure
ASTM 1646- Water infiltration (roof)
ASTM 1680- Air infiltration (roof)
- Weather tightness warranty available
(Contact TMP representative for details)
- 2:12 minimum pitch recommended
(For lower pitches, please inquire)
- Standard panel lengths 5' to 60' - not notched
Standard panel lengths 1' to 60' - notched
(For longer panels, please inquire)
- Onsite roll forming available for longer panels
- Panel options: Striations, Accent Ribs, and Flat Pan
- Retro-fit systems available

PANEL PROFILES

12", 14" 16" & 18" coverage options

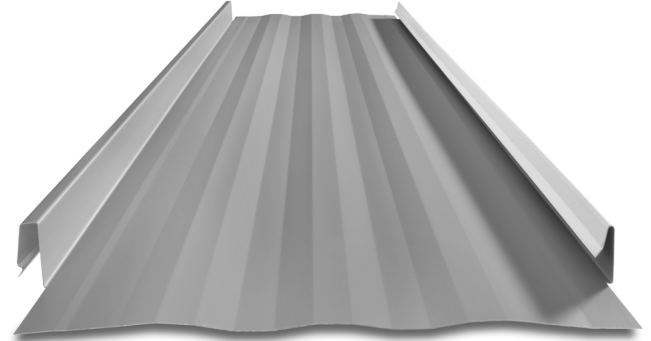

STRIATIONS

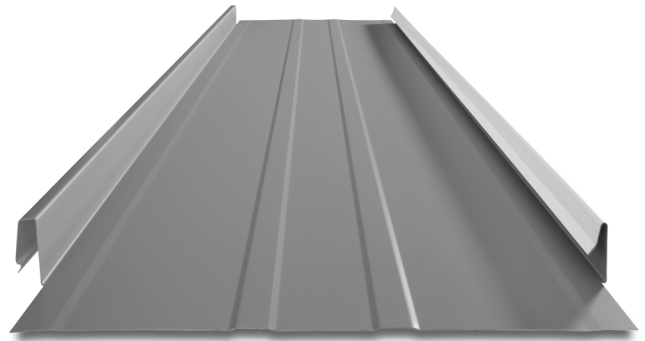

ACCENT RIBS 2 Accent ribs for 12" to 14" panel
3 Accent ribs for 16" & 18" panel



FLAT PAN

SEAM DETAIL

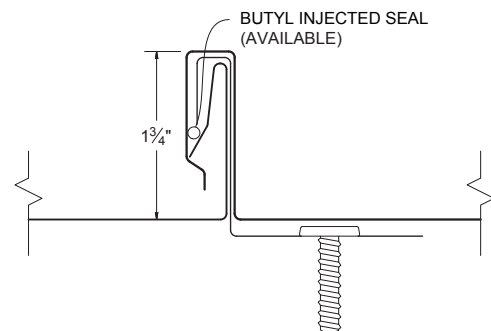

MATERIAL SPECIFICATIONS

- 24 gauge Kynar 500® Painted Steel .0236" (Thickness prior to painting) G-90 Galvanized or AZ-50
- 24 and 22 gauge bare Zincolume® Plus AZ-55 (No finish warranty – 25 yr. perforation warranty)
- ▲ 22 gauge Kynar 500® Painted Steel .029" (Thickness prior to painting) G-90 Galvanized or AZ-50
- ◆ .032" Kynar 500® Painted Aluminum
- 22 gauge Rusteel Plus™ (A606)
- 16 and 20 ounce Copper (Please inquire)
- Kynar 500® and substrate testing data available (See website)
- "Oil Canning" is an inherent characteristic of roof and wall products, and not a defect, which is not a cause for panel rejection

KEY FEATURES

- 21 Standard Colors, 5 Metallic Colors and 4 Specialized Materials
- Kynar 500® Paint System - the ultimate in exterior durability and color retention
- "Cool" color pigments are specially designed to reflect infrared light, reducing heat gain to dwelling, and conform with ENERGY STAR® criteria
- Superior quality, two coat, 70% resin finish, applied at a 1 mil. thickness
- 40 year residential paint warranty
- 20 and 30 year commercial paint warranty: Contact TMP for warranty specifications

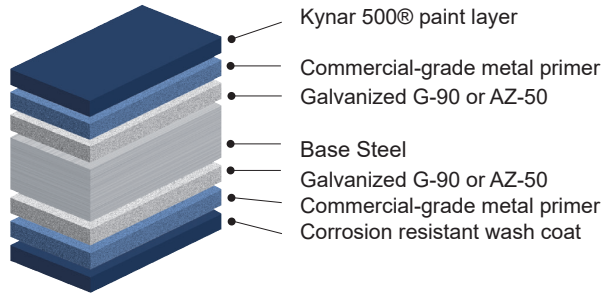

40-Year Residential/20 and 30 Year Commercial Manufacturer's Limited Warranty

STANDARD COOL KYNAR 500® COLORS

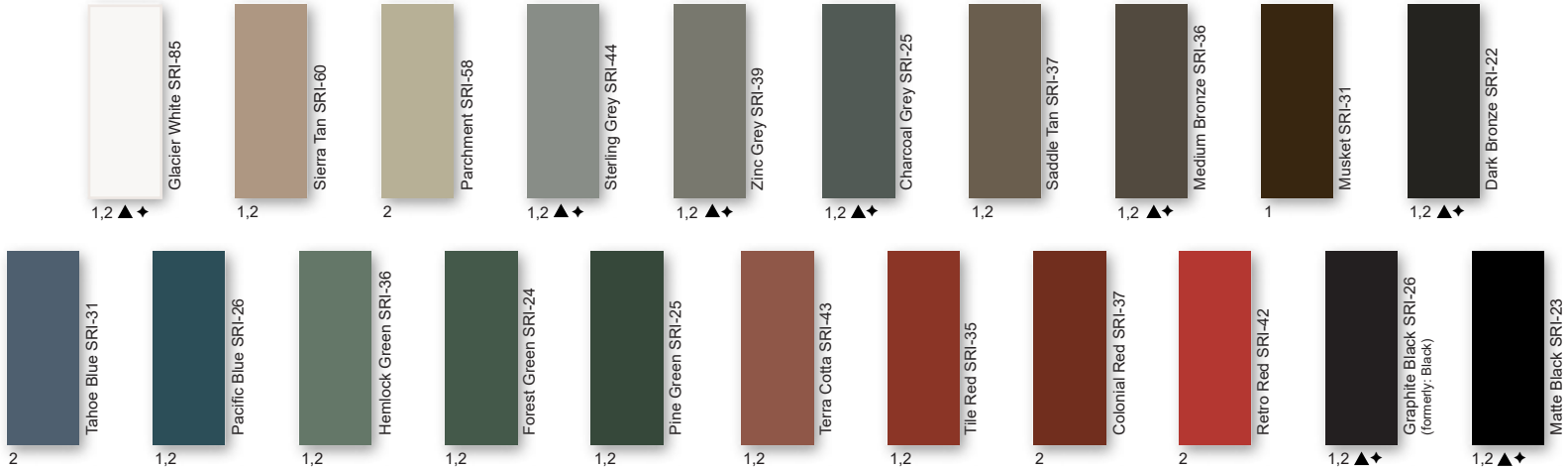

PREMIUM METALLIC COOL KYNAR® COLORS

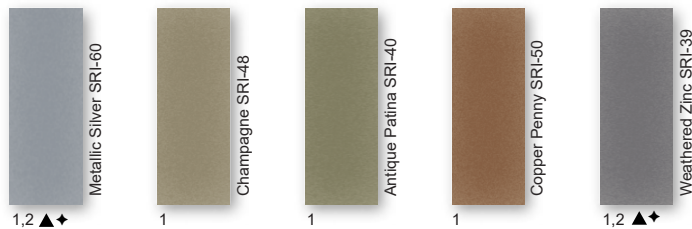

SPECIALIZED MATERIAL

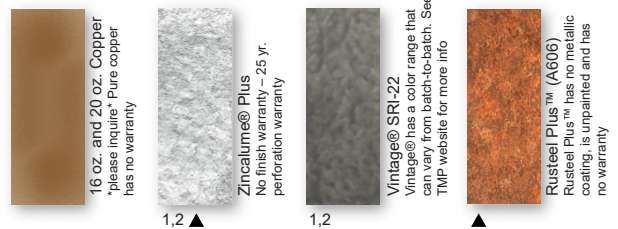

These printed chips provide a close representation of the colors.

Metal samples are available upon request. Coatings are low gloss 10-15% sheen. SRI = Solar Reflective Index. SRI values listed above are in accordance with ASTM E 1980 and are based on actual testing. ***Oil canning is not a cause for material rejection***

Standard Panel Weight				
Width	Gauge	Color	LBS SQFT	LBS LF
14"	24	1	1.36	1.65
18"	24	2	1.28	1.93
18"	22	▲	1.61	2.42
Inquire	.032 Alum	◆	0.6	0.9



Taylor Delivery Fleet



Delivery Fleet

Taylor Metal Products prides itself with quick lead times delivered with our fleet of semi trucks. Our fleet of trucks are owned and operated by TMP. All of our drivers are Taylor Metal Products employees, so when your truck rolls in to deliver, you are dealing with Taylor Metal Products.

Expect consistent and exceptional service with short lead times. The inhouse fleet allows for efficient and cost-effective delivery.



Mounted on the rear of a carrier vehicle, the truck-mounted "piggy-back" forklift will accompany you right to your place of use, opening up unprecedented possibilities in terms of transportation. It can travel sideways, carrying panels up to 40' long, allowing delivery in locations that would typically be considered impossible to reach.

Save time and effort while avoiding potential loading and transport issues; have experienced TMP personnel deliver and unload your order.



Delivery

We will make every attempt to deliver material to the desired location. We may be unable to gain access on tight corners or steep terrain. If the site is deemed inaccessible by our driver, the customer may choose an alternate delivery site within a reasonable proximity. If we are unable to make the alternate delivery, additional charges may be assessed.

The customer is responsible for:

- Determining adequate access for delivery ahead of time.
- Meeting the delivery at the agreed upon time.
- Providing adequate resources (1-4 people as needed) for off loading materials.
- **A charge of \$100 per hour may be added for deliveries that go beyond their allotted time**
- Check the shipment at the time of delivery.
- Verify material quantities against the shipping/packing list.
- Note any damage or discrepancies upon the paper work at the time of delivery and notify Taylor Metal Products within 48 hours of delivery.

Delivery times are usually scheduled one day in advance. Taylor Metal Products will make every effort to make the delivery at the scheduled time. Please be aware that there may be conditions beyond our control such as traffic, mechanical failures, road closures, etc. which may affect our schedule.

Will Call/Loading

Flatbed trailers and trucks are best suited to transport metal roofing materials. These can be loaded from the side with a forklift and tied down in a safe and secure manner.

We are not able to load materials onto vehicles and/or trailers which are not suitable or may be hazardous to load. Please be aware that if we find a vehicle to be inappropriate, we reserve the right to refuse to load your order.

Unacceptable examples include: boat trailers, vans, buses, motor homes, campers and box trailers. Pickup racks which do not have sufficient supports for the weight or are not long enough to support bundles are also unacceptable.

Taylor Metal Products is **not** responsible to tie down loads nor do we provide any tie down materials. Please bring tie downs to secure your load (string or twine are **not** acceptable for this purpose).

Consider having your order delivered on one of our trucks with a piggy back forklift.



Notes to Designer/Installer

Taylor Metal Products is providing the following details as an aid in design. The details in this guide are not inclusive to all design situations. The designer/installer is responsible for modifications and should take into consideration all aspects of the project including climate conditions, such as, snow and wind, as well as, building code requirements, building design, building usage and maintenance requirements.

Installation should be performed only by qualified installers familiar with metal roofing systems and industry standards. For details not shown in this guide, refer to the Sheet Metal and Air Conditioning Contractors National Association (SMACNA) architectural sheet metal manual for proper design. For manufacturer's weather tightness warranties – all details must be preapproved by Taylor Metal Products technical representative.

The Standard gauge for all products in this guide is 24 gauge and the standard finish is Kynar 500®. We recommend specifying all flashings be the same gauge, color, and finish as the panels to ensure long-term durability and color match.

Substrates

Details in the manual are all shown over solid substrate. **Versa-Span™** can be used over spaced purlins. For solid substrate, **Taylor Metal Products** recommends 5/8" plywood or metal decking. Contact a TMP representative with questions about panel attachment to varying substrates.

Underlayment

For roofs with pitches below 3:12, High Temp Ice and Water shield underlayment must be installed across the entire surface (projects with manufacturer's weathertightness warranties require the TMP private label product). For pitches steeper than (or equal to) 3:12, High Temp Ice and Water is necessary at all perimeter locations, eave, ridge, valley, hips, sidewall, endwall, prow and penetrations. The remaining of the roof's field areas can then be covered with approved synthetic felt. If local codes or specifications require a Class A fire rated assembly, Polystick XFR or Titanium FR (both products are distributed by TMP) must be installed over the entire roof with combustible decks.

Follow manufactures instructions carefully for all underlayment installation.

Drag Load Requirements

All panels must be pinned at one end to resist the drag load caused by snow loads, live loads, and the weight of the panel. Drag load is a function of roof slope, actual load and length of panels. Contact **Taylor Metal Products** for specific drag load requirements.

Ventilation/Insulation

It is the responsibility of the designer to determine the material types needed to control condensation and to insulate and ventilate the roof system. Applications over rigid insulation may require blocking for solid attachment and framing the perimeter for installation of perimeter flashings.

Oil Canning

Flat metal surfaces will display waviness commonly referred to as “oil canning.” Oil canning is caused by a variety of conditions. Steel mill tolerances, variations in or uneven substrates and roofing underlayments. Oil canning is a characteristic of metal roofing, not a defect and is not a cause for rejection. **Taylor Metal Products** offers **Versa-Span™** with striations or accent ribs to help minimize oil canning.

Thermal Movement

The Panels and the flashings must be allowed to expand and contract, especially with longer length panels. The panel may need to have a slight gap where the panel hooks the offset cleat to allow for thermal movement of the panels.

Snow Design

The following details do not address all conditions for snow environments. Consult with the designers, engineers, and others for acceptable details to accommodate your project and climate conditions. When possible gutters, valleys, pitch changes or other penetrations should be minimized in snow areas.

All roof penetrations should be located as close to the ridge or “pin point” top of roof. Snow country requires special designs for valleys to accommodate accumulation of snow and ice from uphill panels. Roof design should be considered in snow areas. Roof design should help resist the melting and freezing of snow and ice.

A fit for purpose roof design has the greatest impact on maintaining a damage free roof system in snow areas. Please contact a Taylor Metal Products representative for assistance in detail designs and appropriate panel selection for specific climate and building conditions.

Handling / Storage & Safety

Handle materials with care when off-loading or moving materials to avoid damage to panels or flashings. Long panels may require two or more pick-up points, properly spaced to avoid damaging panels. Plan ahead; contact Taylor Metal Products for recommendations on handling/hoisting long panels.

Store the panels, flashings and accessories in a dry, well ventilated area, off the ground. If covering, allow ventilation around panels. Elevate one end of bundle to allow drainage of wet materials.

Wear clean, soft-soled shoes when walking on roofing panels to avoid damage to the painted finish.

Take care that sand, gravel, dirt, etc. sticking to your shoes is not carried onto the roof, scratching or otherwise damaging the finish on the roofing material. Walking on asphalt impregnated felt paper, especially on a hot day, can cause the asphalt to stick to your shoes and be tracked on to the roofing material.

Take care when painting to avoid getting over spray on the roofing material. Remember that wind can carry paint particles some distance. Over spray can cause the finish of the roofing material to look dull and may void your warranty.

Secure materials, especially when leaving the site, on the ground or roof to prevent winds from moving the materials. Wind-blown materials may cause damage to the material, property or persons.

Always use proper safety equipment and attire to minimize risk of cuts or other injuries.

Do not walk on panels that have not been completely installed.

Do not walk on major ribs of panels.

Metal roofs that are wet or dusty can be extremely slippery. Wear soft soled shoes and a safety harness to minimize risk of falling.

Avoid installing metal panels in windy conditions.

Safety considerations are the responsibility of the installer and his crew. Be sure to **use common sense** and generally accepted safety practices when installing roofing materials.

STANDARD EAVE DETAIL

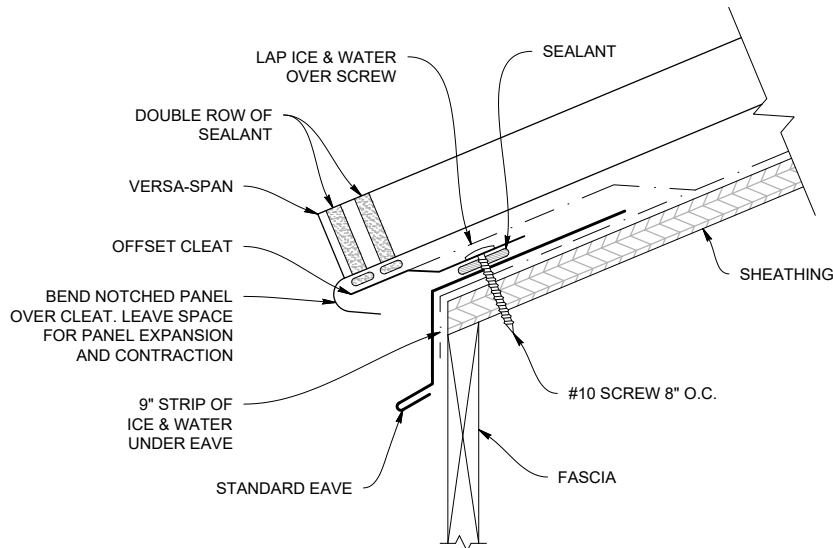

STANDARD EAVE (VSES)

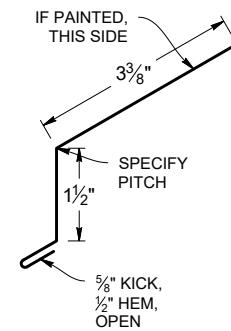

OFFSET CLEAT (VSOC)

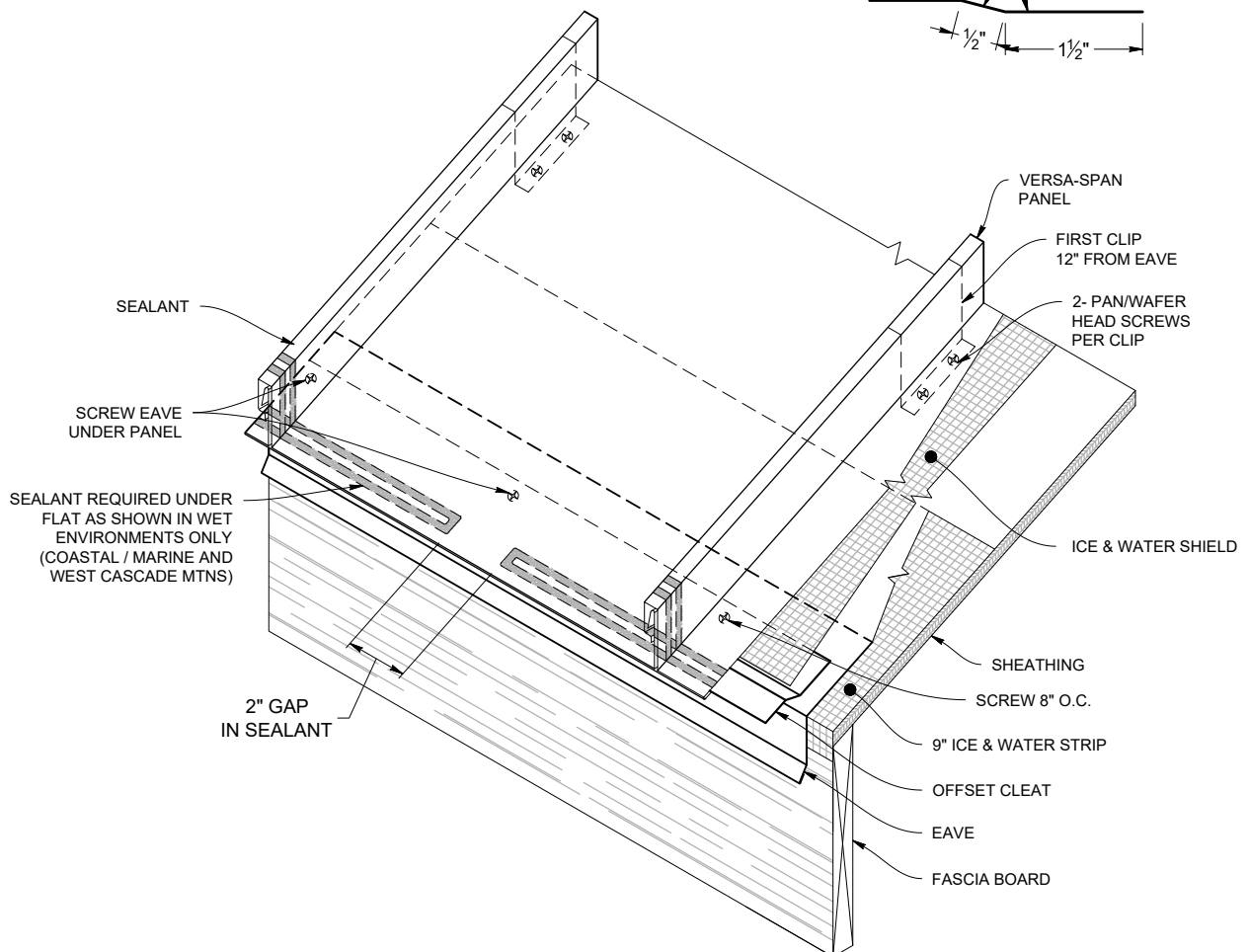
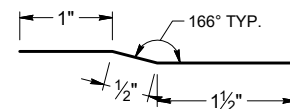

Note: All screws must be fastened into solid substrate.
Flashing must be lapped 4" with 3 rows of sealant.

Hook Eave

HOOK EAVE DETAIL

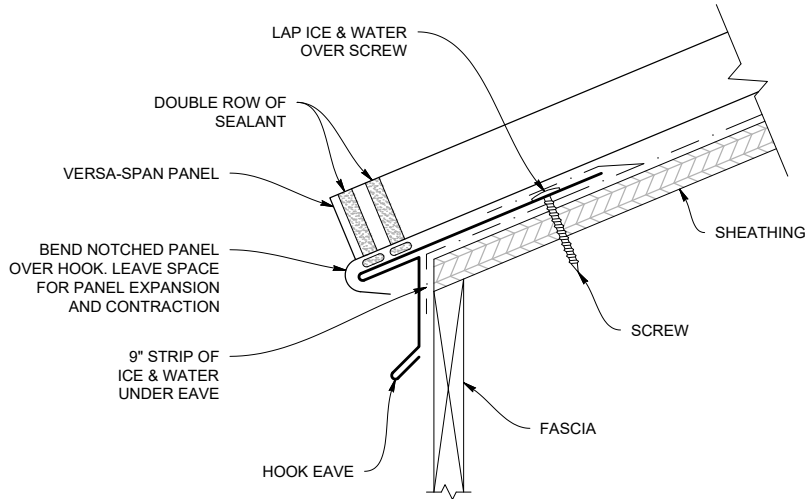

HOOK EAVE (VSEH)

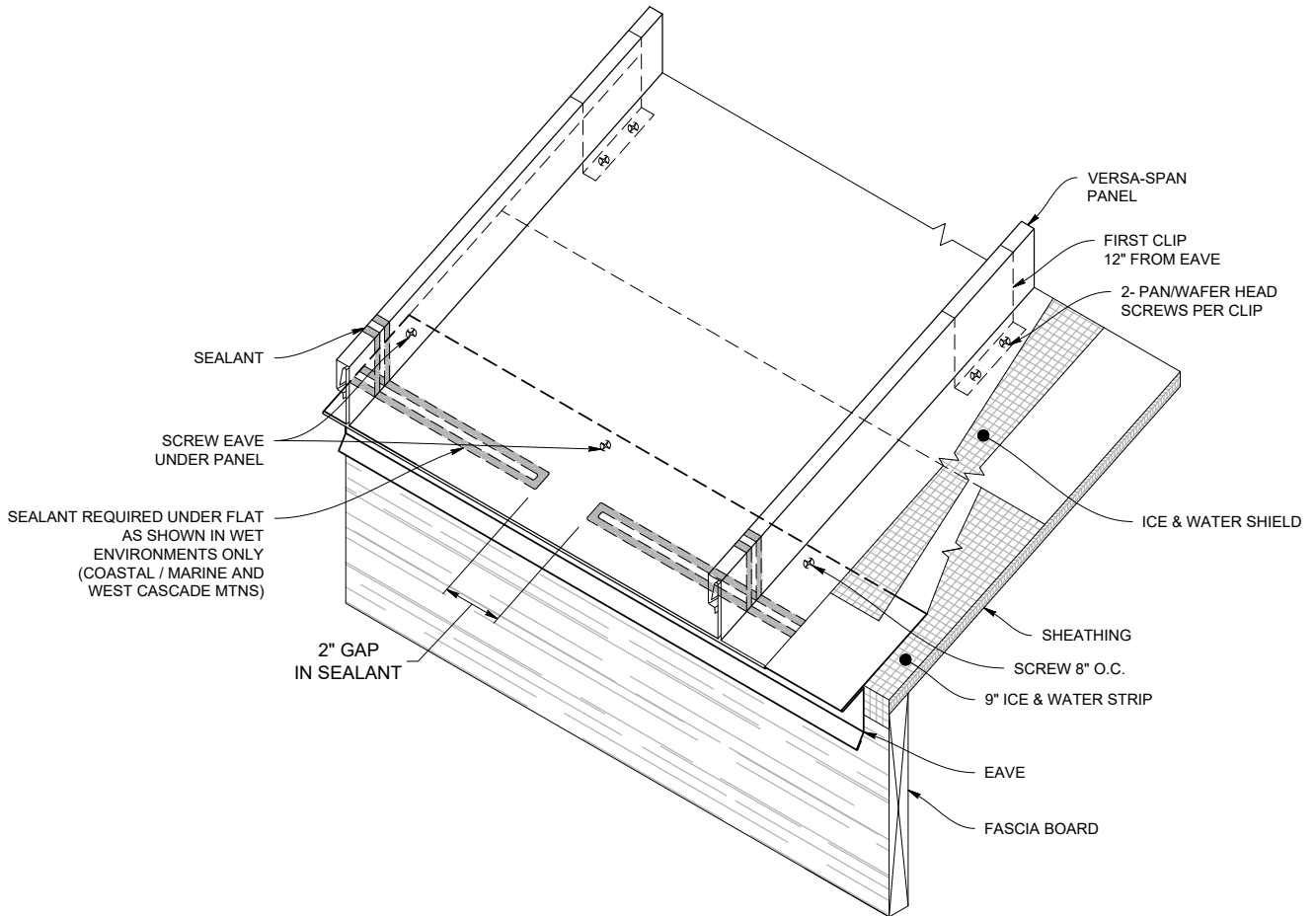
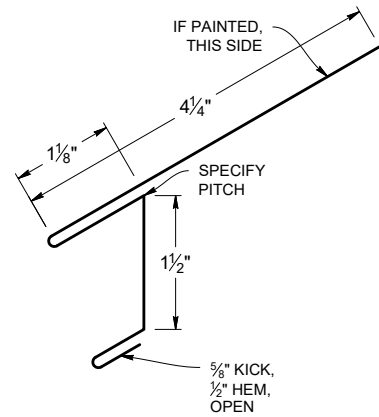

Note: All screws must be fastened into solid substrate.
Flashing must be lapped 4" with 3 rows of sealant.

HOOK EAVE WITH GUTTER DETAIL

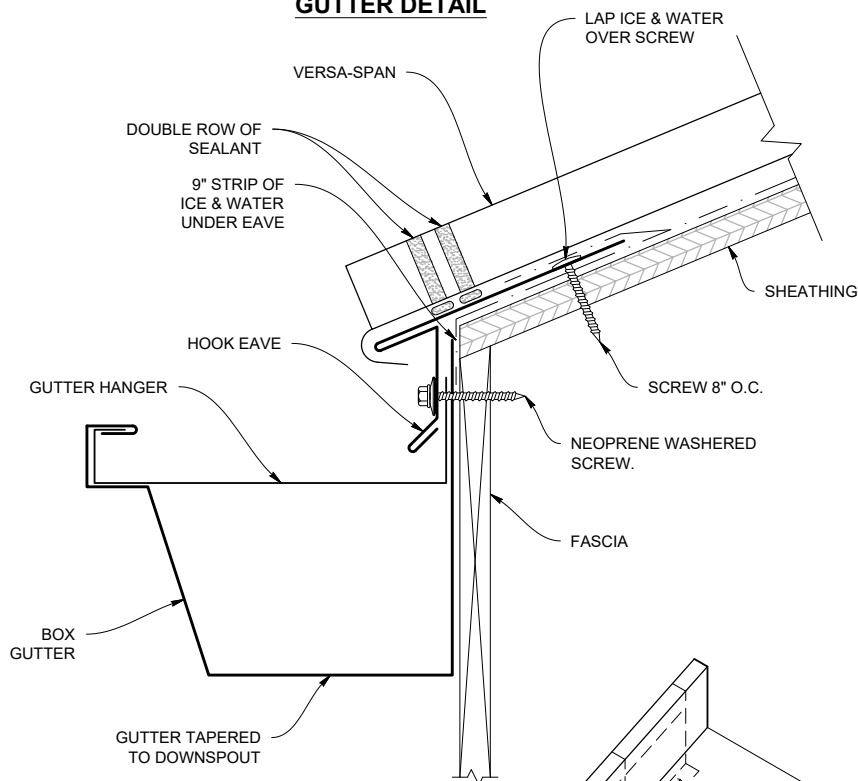

BOX GUTTER (VSBG)

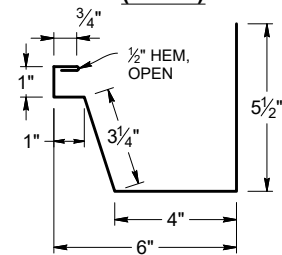

HOOK EAVE (VSEH)

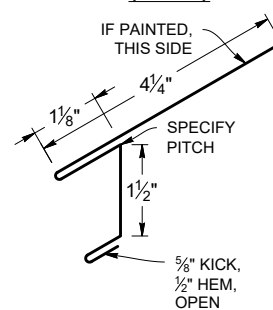

BOX GUTTER HANGER (AGH6)

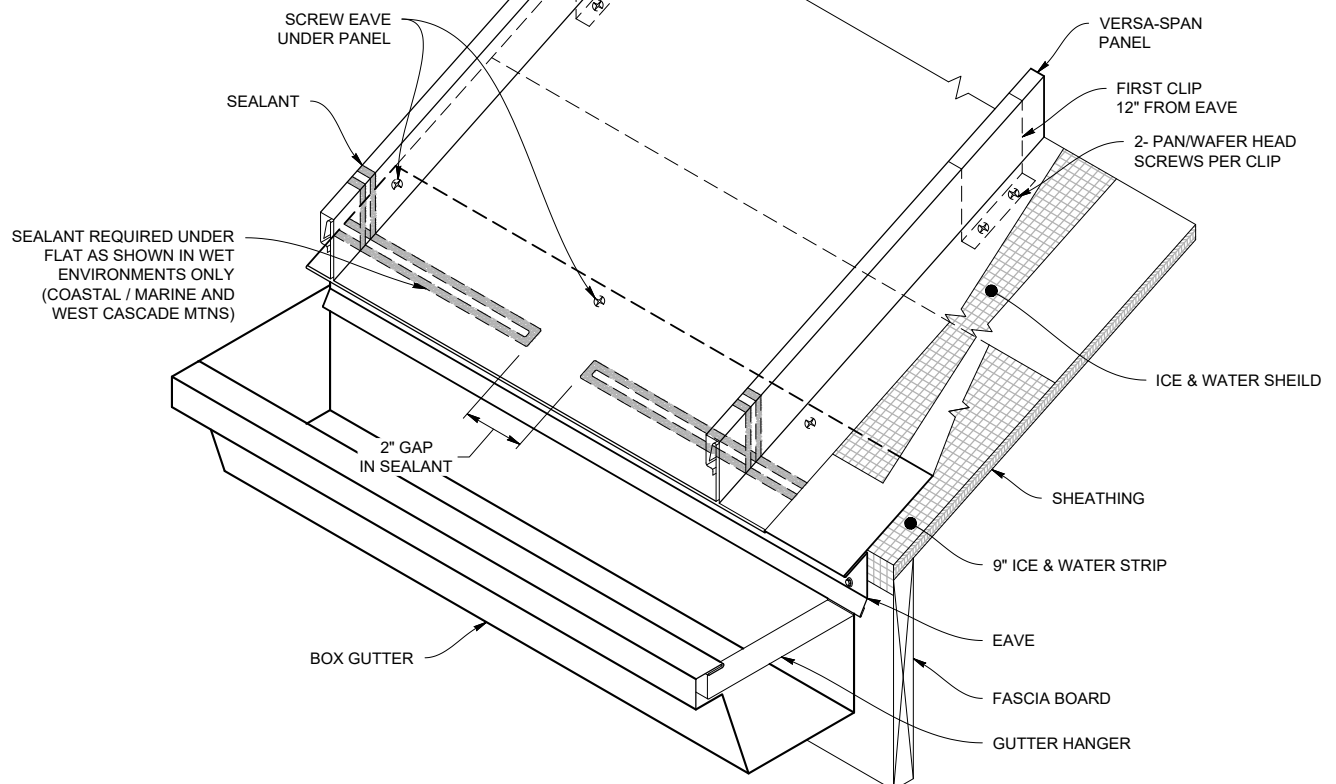

Note: All screws must be fastened into solid substrate.
Flashing must be lapped 4" with 3 rows of sealant.

Standard Ridge

STANDARD RIDGE DETAIL

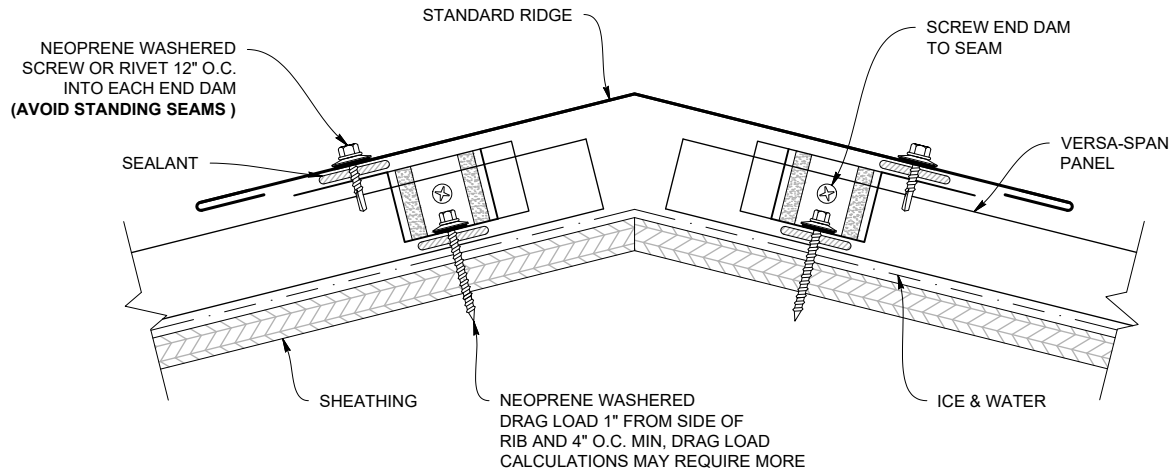

STANDARD RIDGE (VRS)

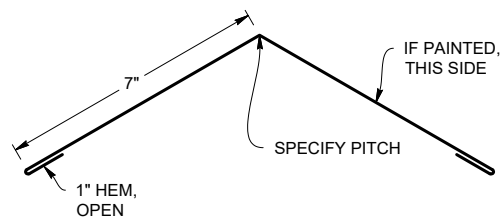

RIDGE LAP

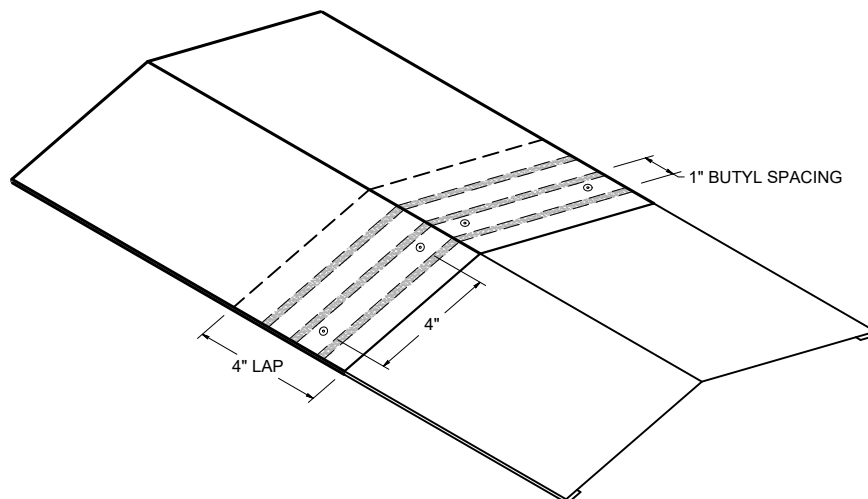

Note: All screws must be fastened into solid substrate.
Flashing must be lapped 4" with 3 rows of sealant.

WT RIDGE VENTED DETAIL

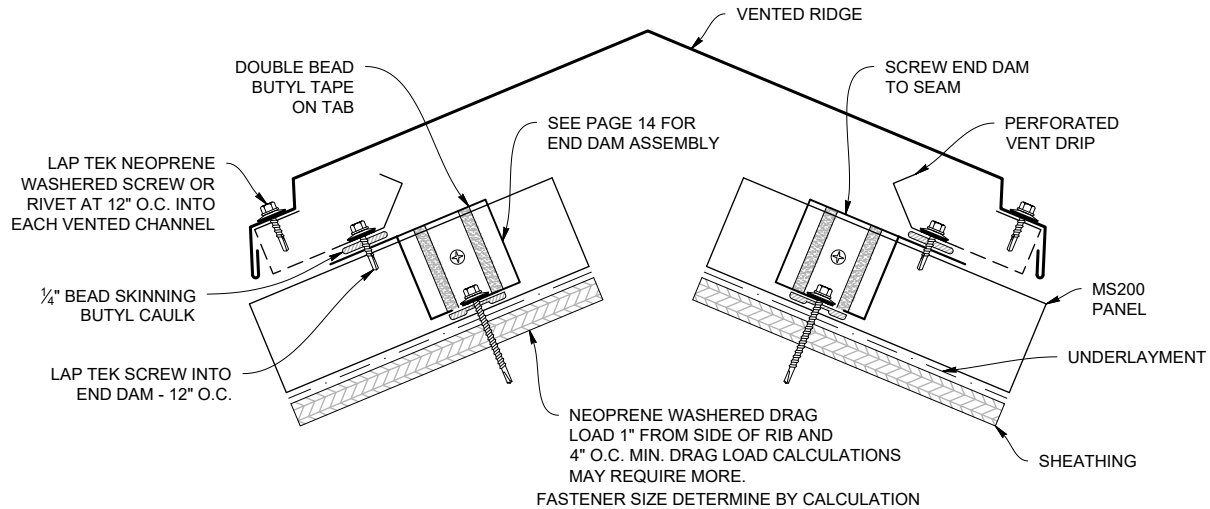

WT RIDGE VENTED (VSWTRFV)

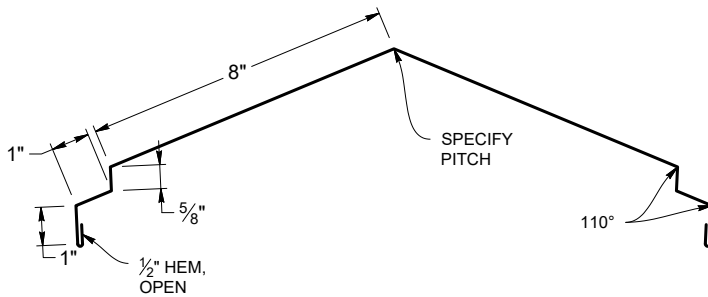

PERFORATED VENT DRIP (VSPVD)

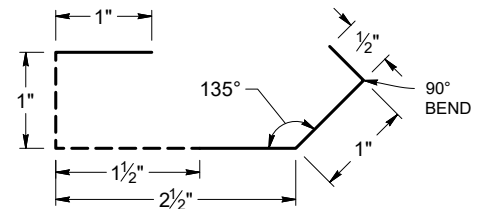

RIDGE LAP

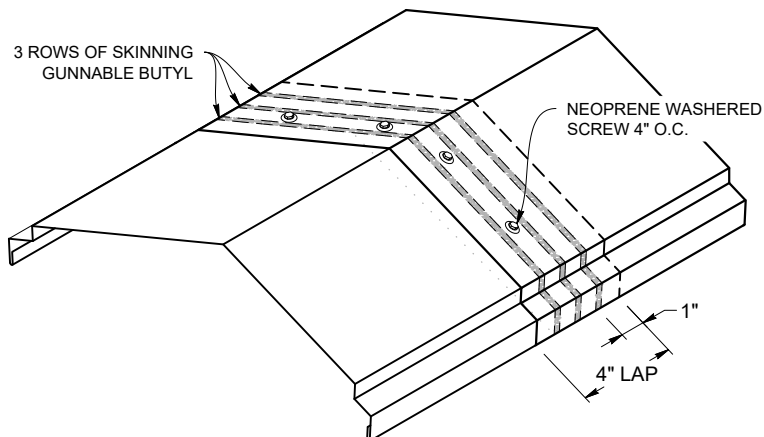

Note: All screws must be fastened into solid substrate.
Flashing must be lapped 4" with 3 rows of sealant.

End Dam Attachment

END DAM ATTACHMENT APPLICATION

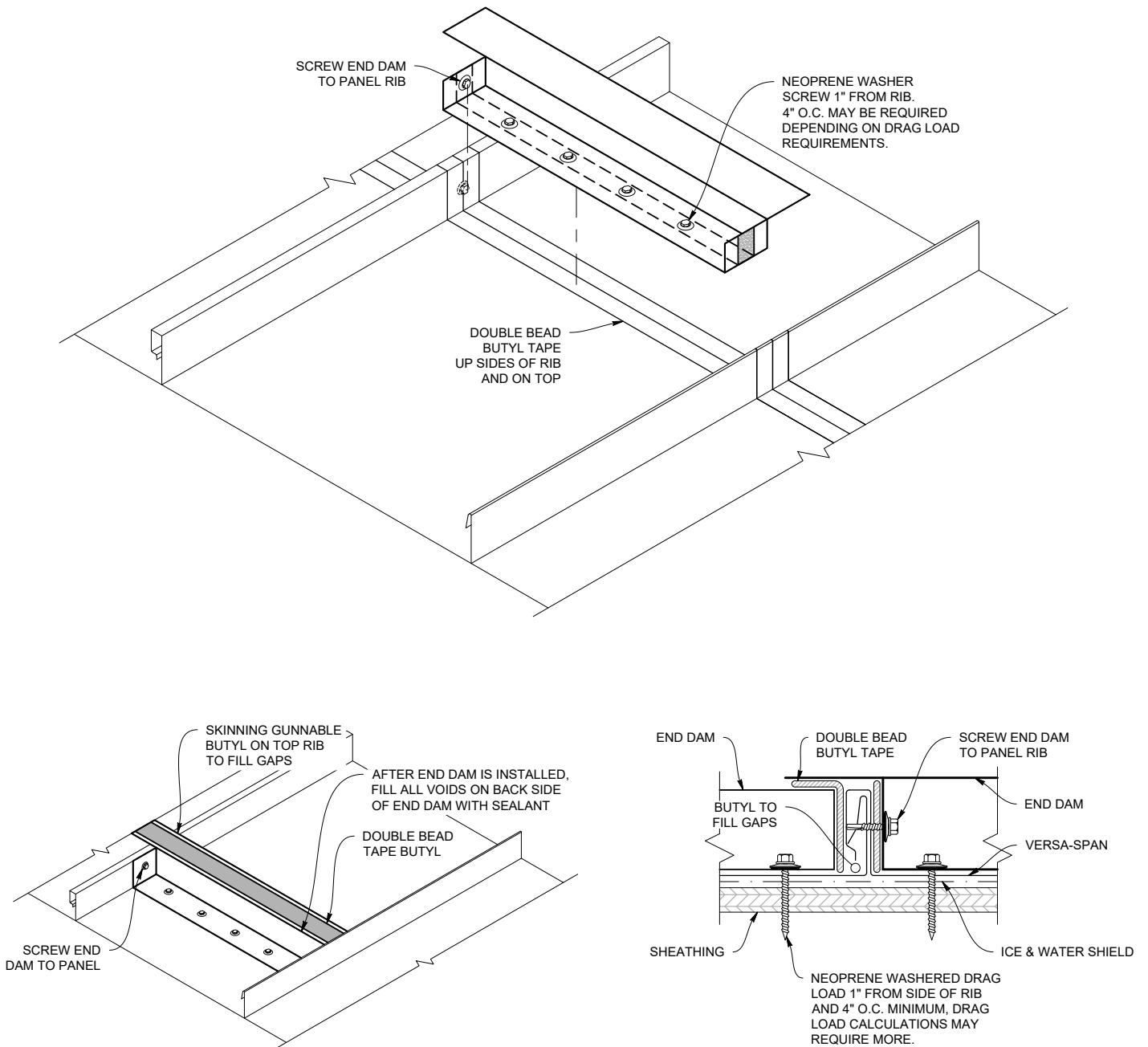

Note: All screws must be fastened into solid substrate.
Flashing must be lapped 4" with 3 rows of sealant.

**VALLEY 24" FLASHING
(VSVF)**

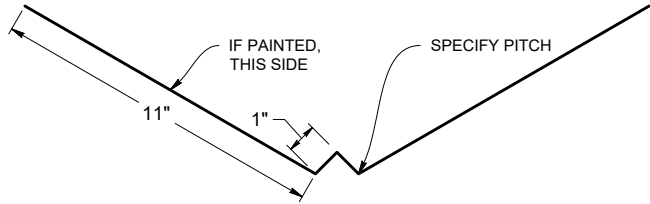

**OFFSET CLEAT
(VSOC)**

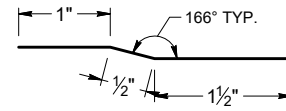

**VALLEY 24" DETAIL
(2:12 or Greater Pitch)**

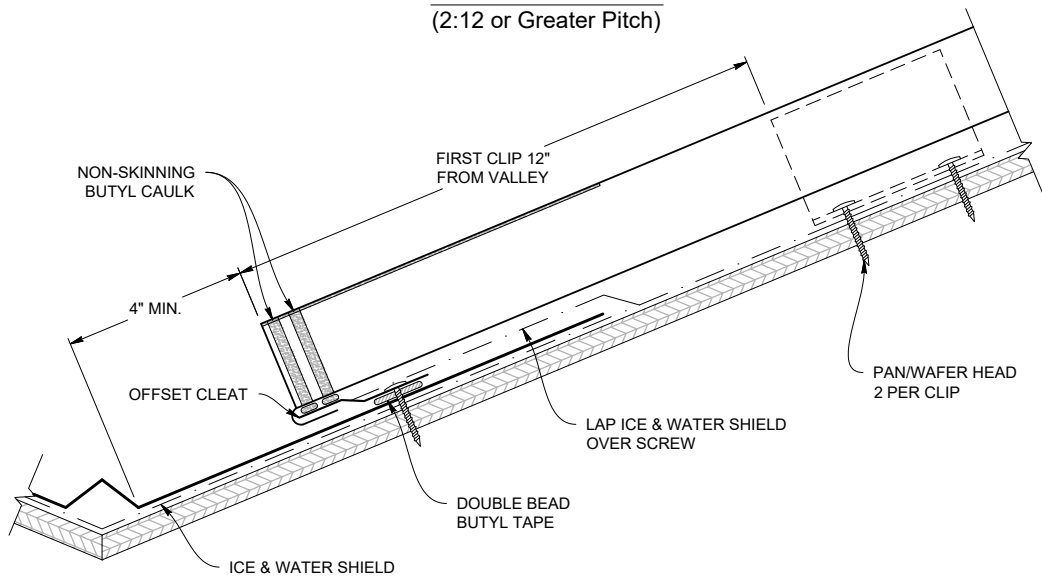

**VALLEY LAP
(2:12 or Greater Pitch)**

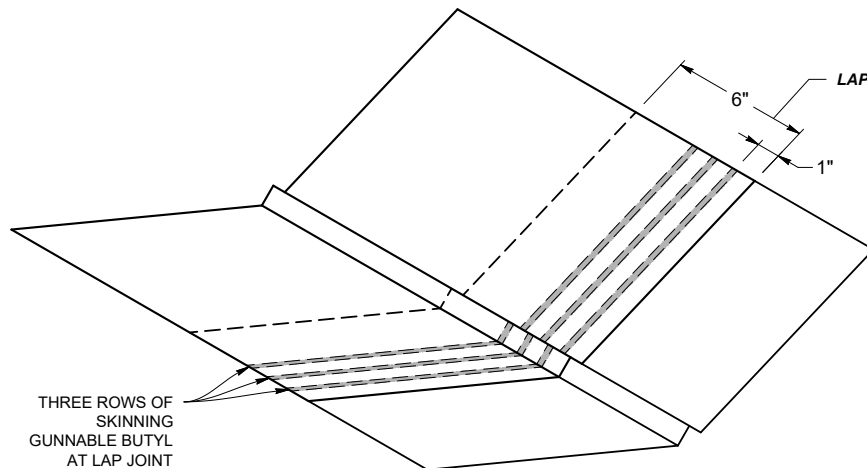

Note: All screws must be fastened into solid substrate.
Flashing must be lapped 4" with 3 rows of sealant.

Valley - Low Slope

Pitch Less than 2:12

LOW SLOPE VALLEY DETAIL

(Less Than 2:12 Pitch - Not Recommended)

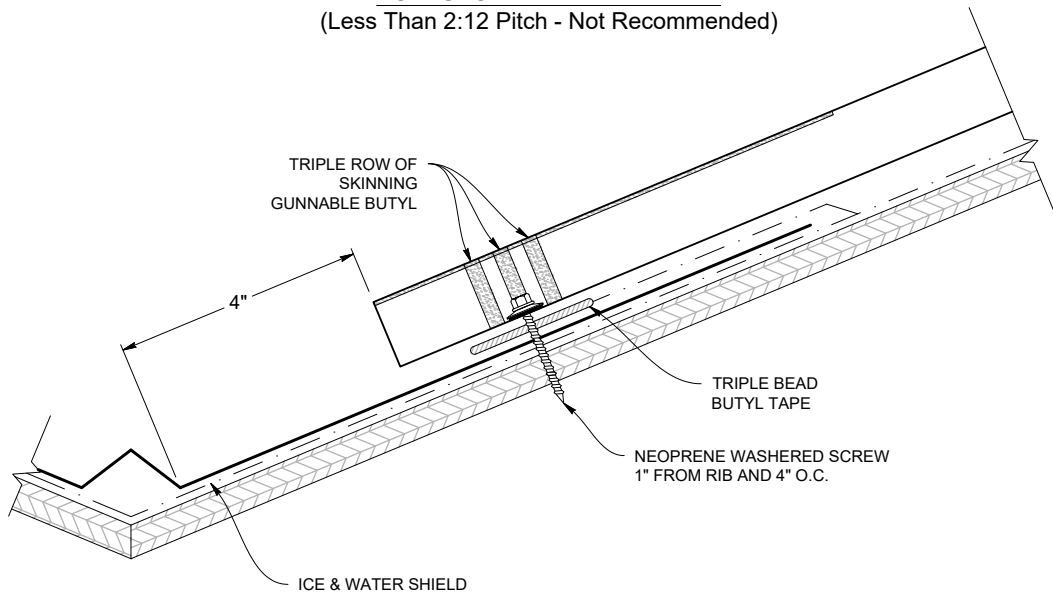

VALLEY FLASHING (VSVF)

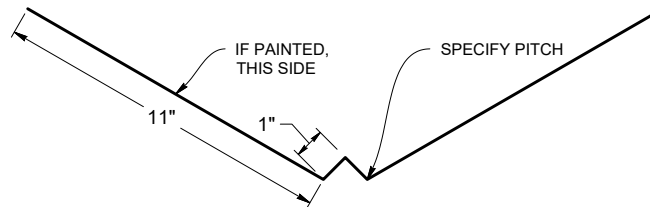

LOW SLOPE VALLEY LAP

(Less Than 2:12 Pitch - Not Recommended)

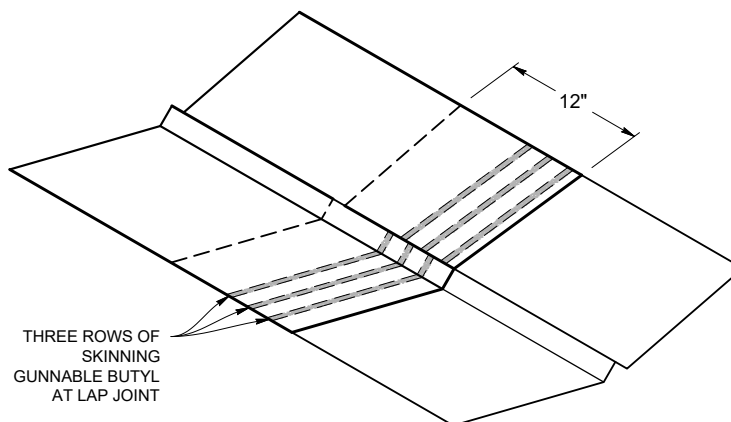

Note: All screws must be fastened into solid substrate.
Flashing must be lapped 4" with 3 rows of sealant.

STANDARD GABLE DETAIL

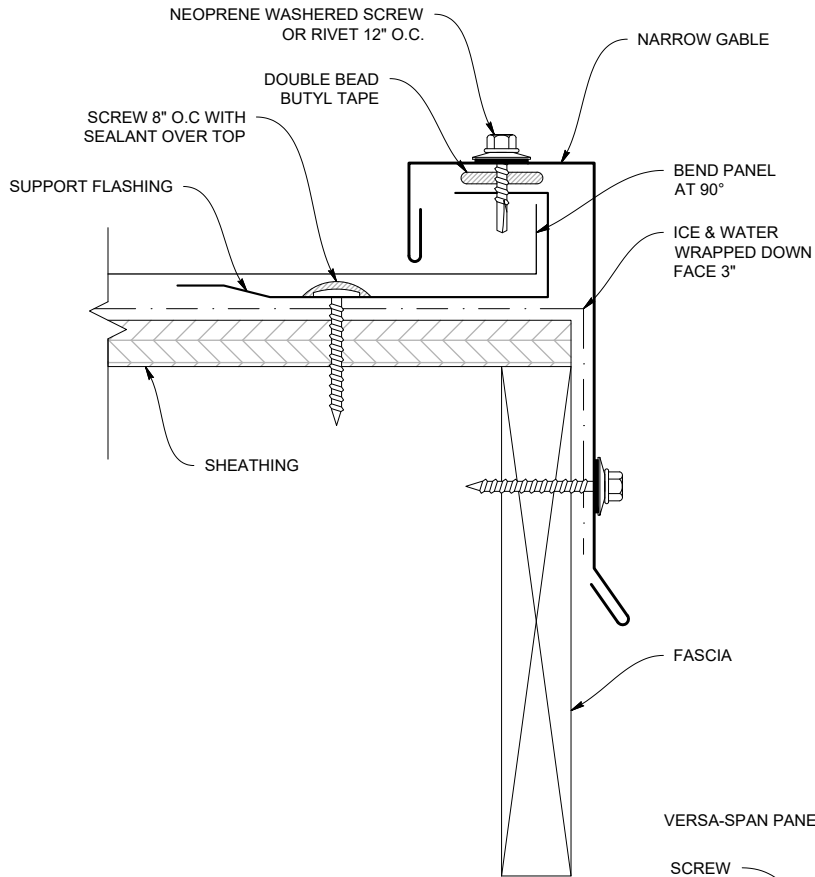

STANDARD GABLE (VSGS)

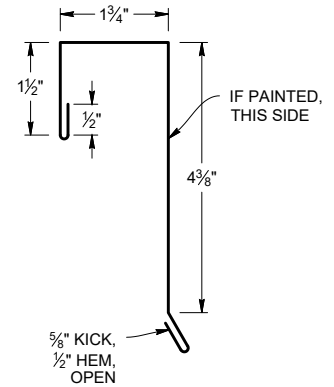

SUPPORT FLASHING (VSSF)

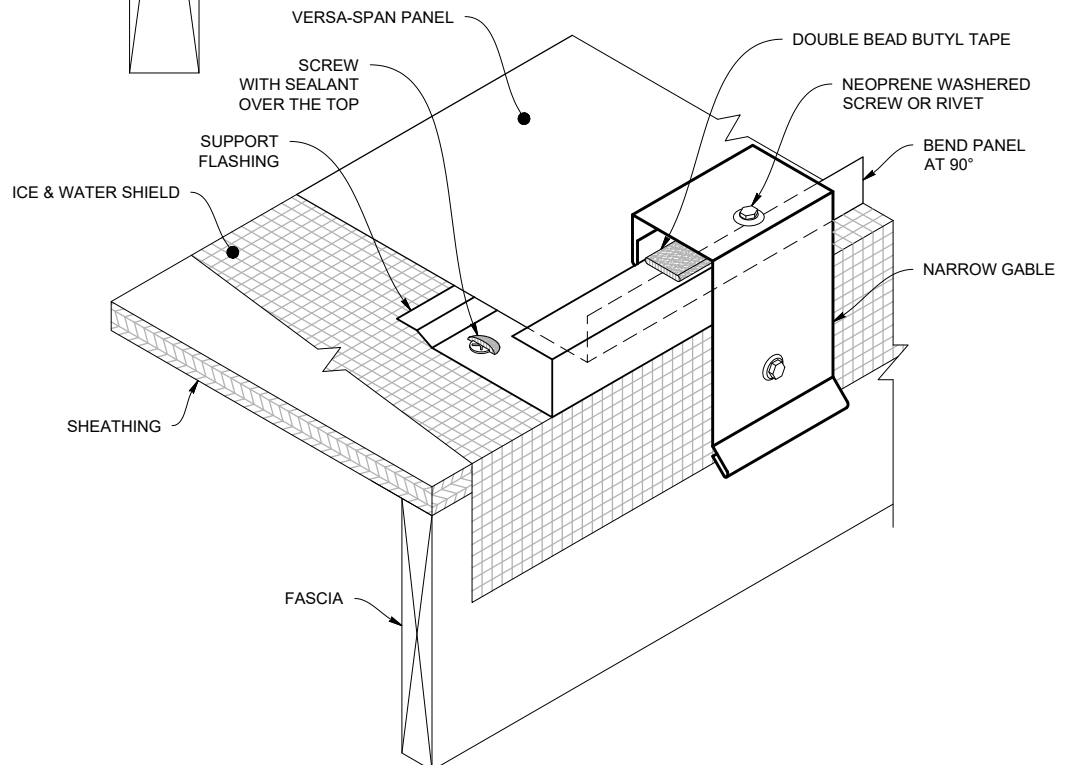
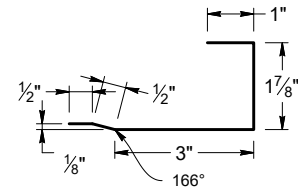

Note: All screws must be fastened into solid substrate.
Flashing must be lapped 4" with 3 rows of sealant.

Alternate Gable

ALTERNATE GABLE DETAIL

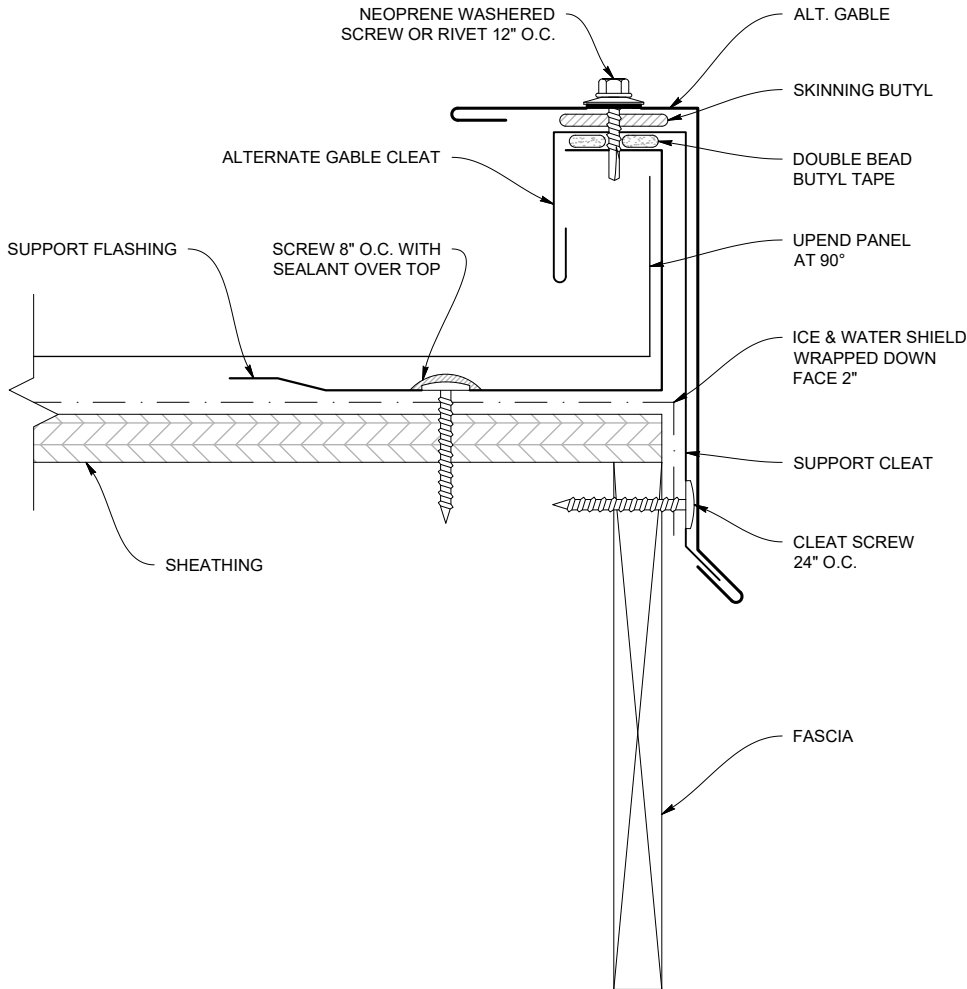

ALTERNATE GABLE (VSAG)

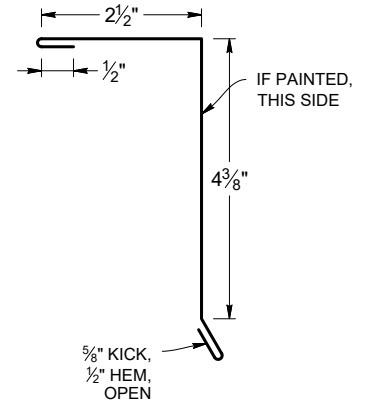

ALTERNATE GABLE CLEAT (VSAGC)

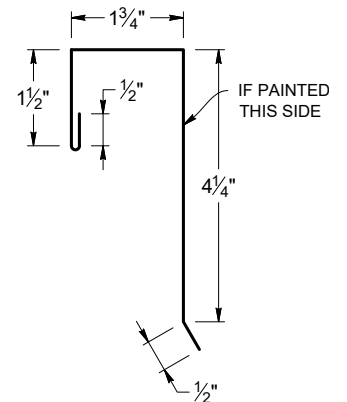

SUPPORT FLASHING (VSSF)

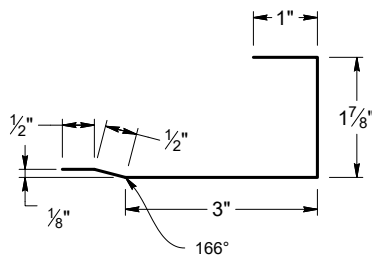

Note: All screws must be fastened into solid substrate.
Flashing must be lapped 4" with 3 rows of sealant.

SIDEWALL DETAIL

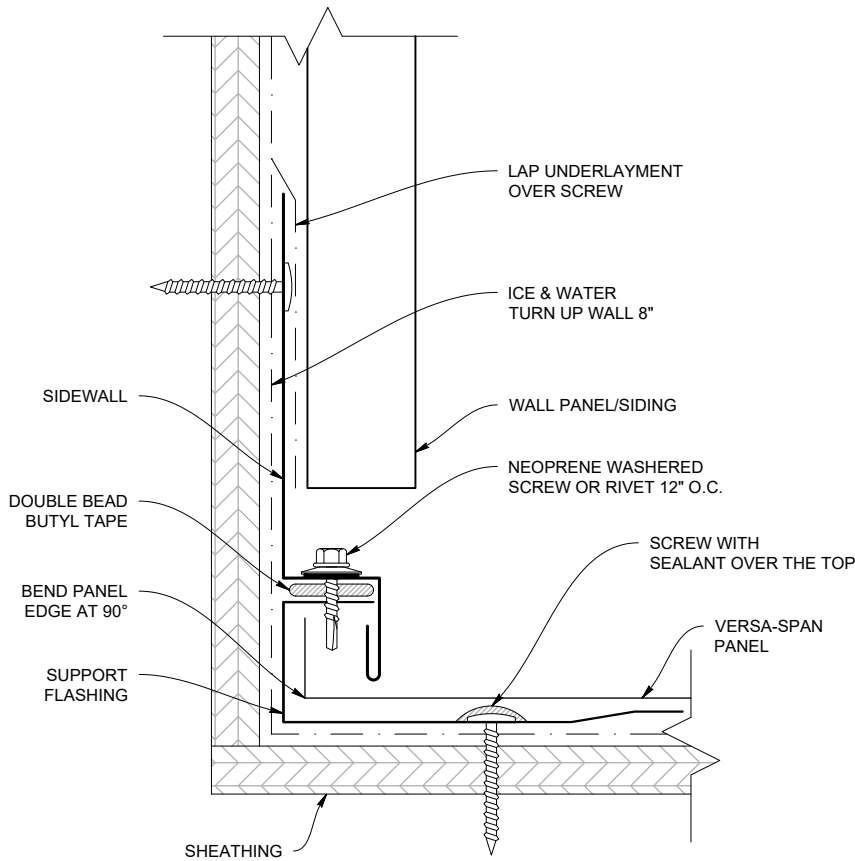

SIDEWALL (VSSW)

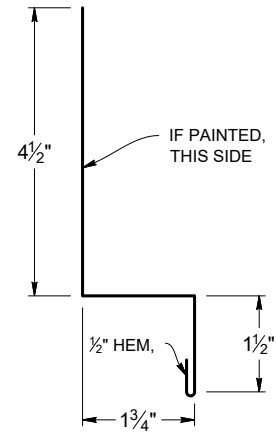

SUPPORT FLASHING (VSSF)

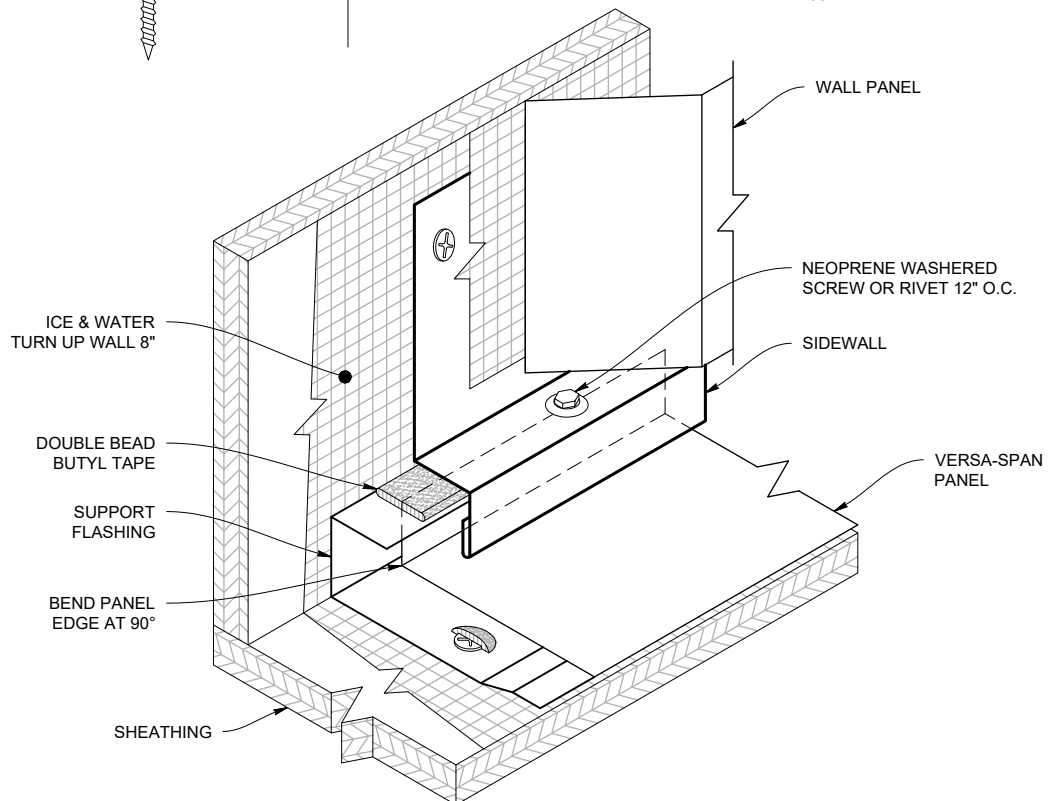
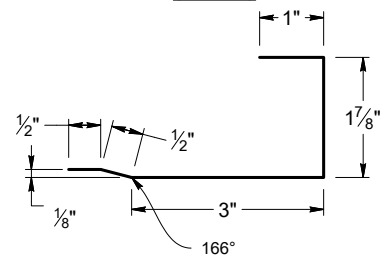

Note: All screws must be fastened into solid substrate.
Flashing must be lapped 4" with 3 rows of sealant.

Peak Flashing

(Ridge End Cap)

PEAK FLASHING DETAIL (Ridge End Cap)

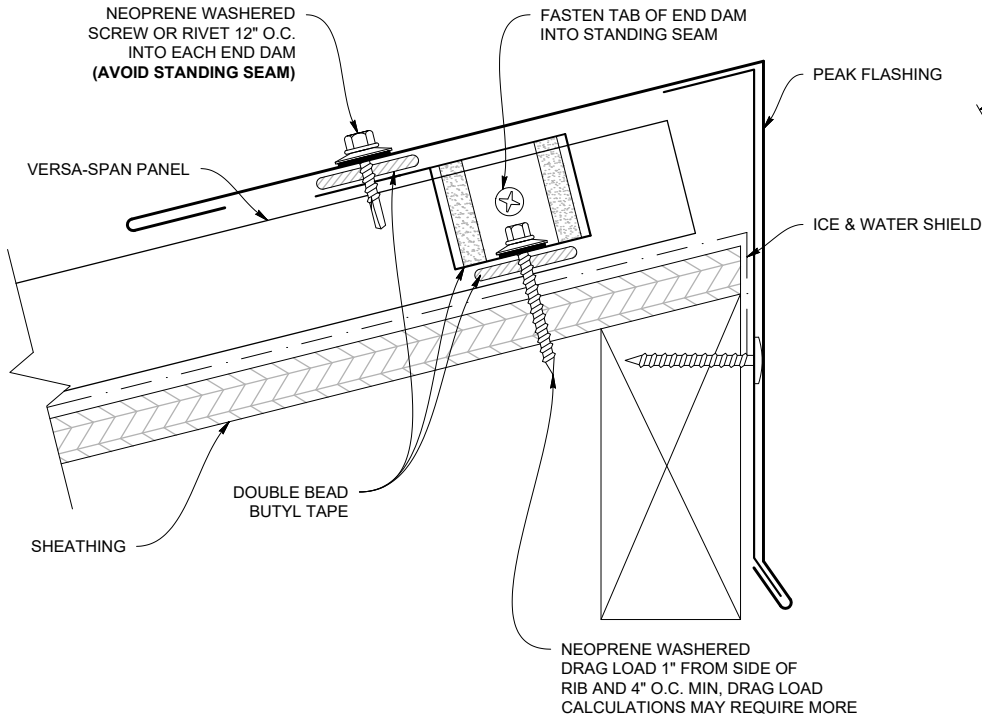

PEAK FLASHING (Ridge End Cap) (VSREC)

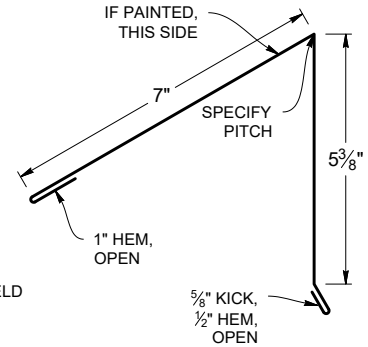

PEAK CLEAT (VSRECC)

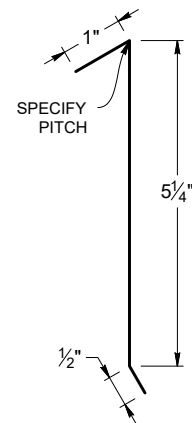

PEAK FLASHING LAP

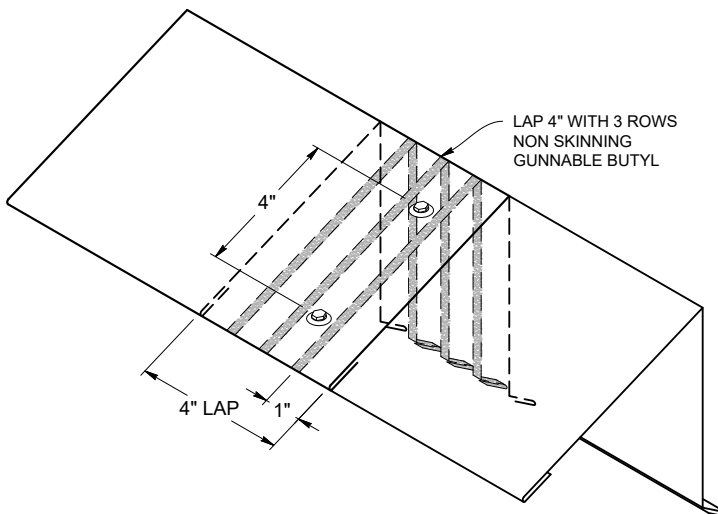

Note: All screws must be fastened into solid substrate. Flashing must be lapped 4" with 3 rows of sealant.

WT VENTED PEAK FLASHING DETAIL (Ridge End Cap)

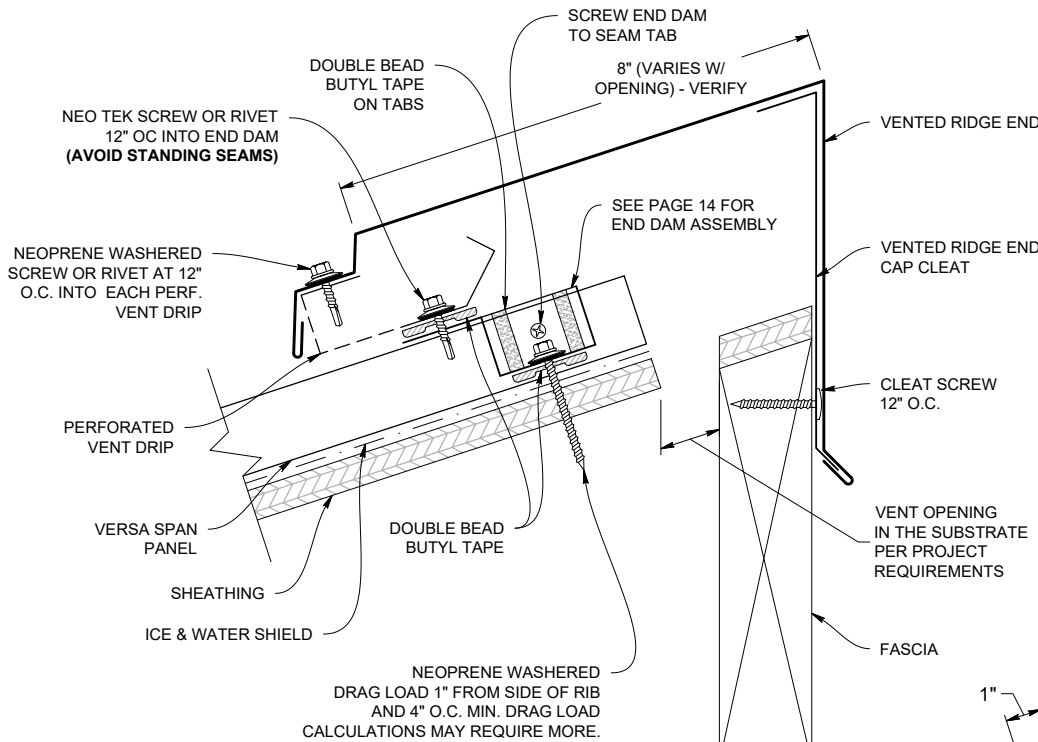

VENTED PEAK CLEAT (VSVRECC)

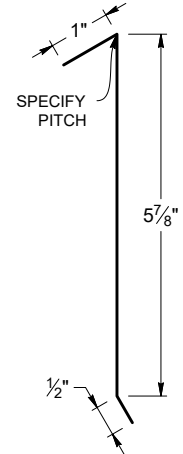

WT VENTED PEAK FLASHING (VSWTREC V)

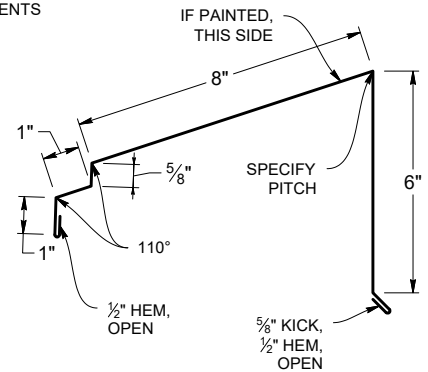

VENTED PEAK FLASHING LAP

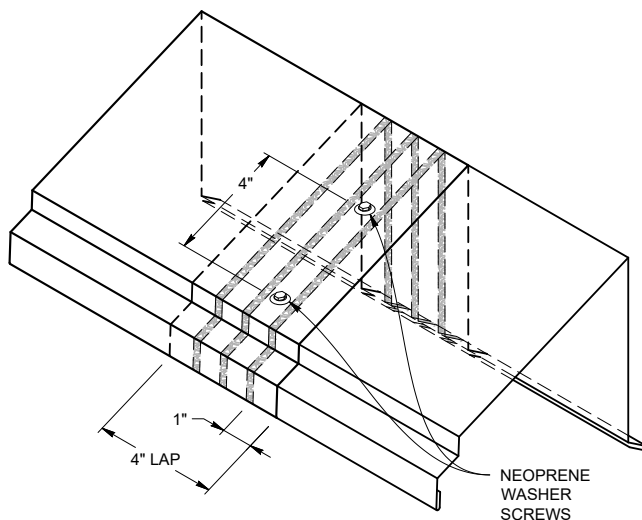

PERFORATED VENT DRIP (VSPVD)

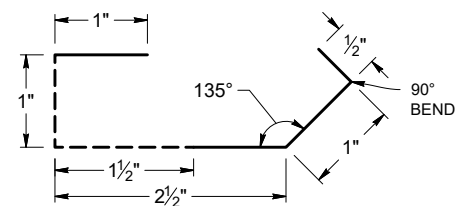

Note: All screws must be fastened into solid substrate. Flashing must be lapped 4" with 3 rows of sealant.

Pitch Change

PITCH CHANGE DETAIL

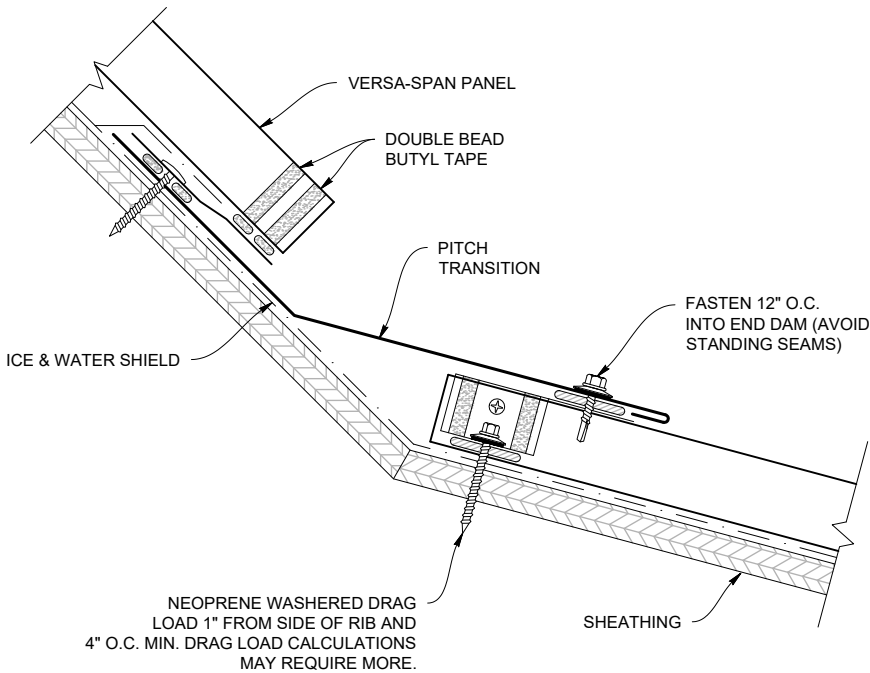

INSIDE PITCH CHANGE FLASHING (SLPCIN)

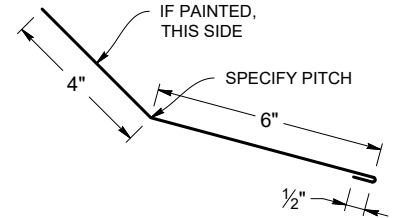

OFFSET CLEAT (VSOC)

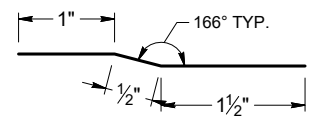

PITCH CHANGE LAP

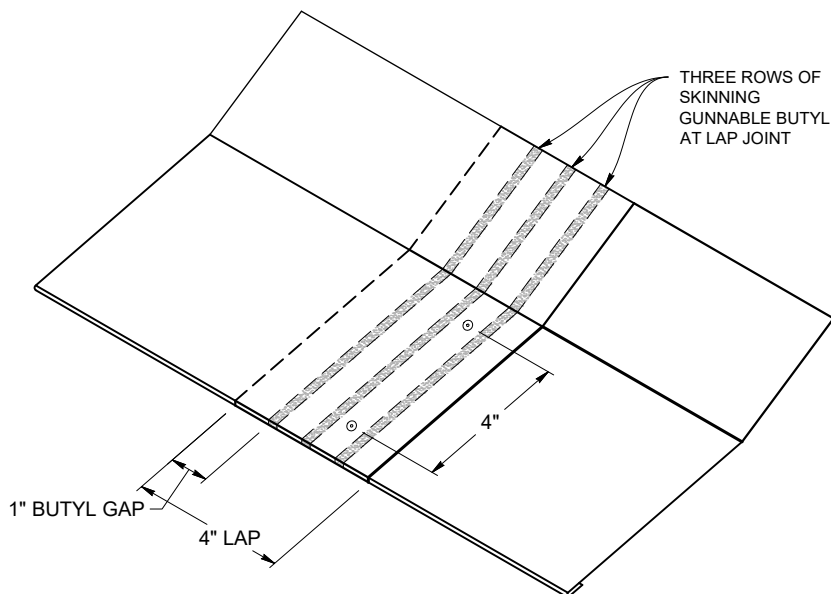

Note: All screws must be fastened into solid substrate.
Flashing must be lapped 4" with 3 rows of sealant.

ENDWALL DETAIL

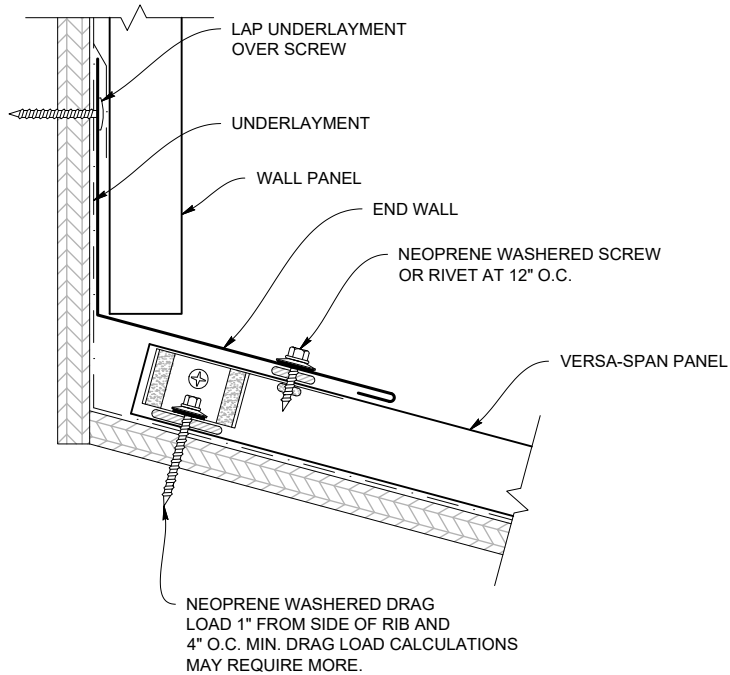

ENDWALL FLASHING (VSEW)

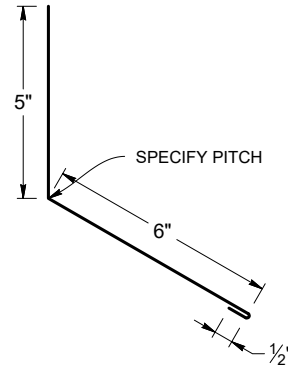

ENDWALL LAP

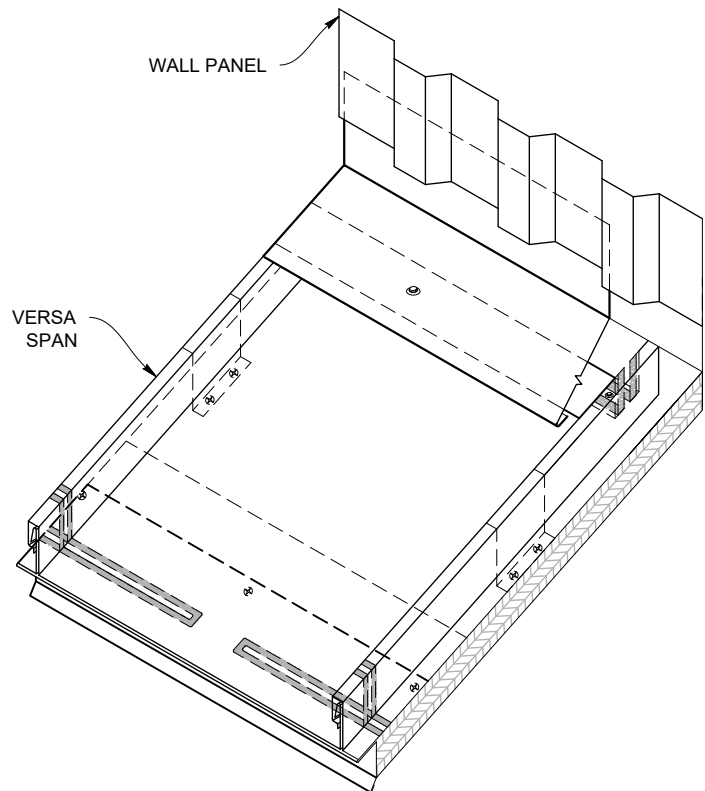
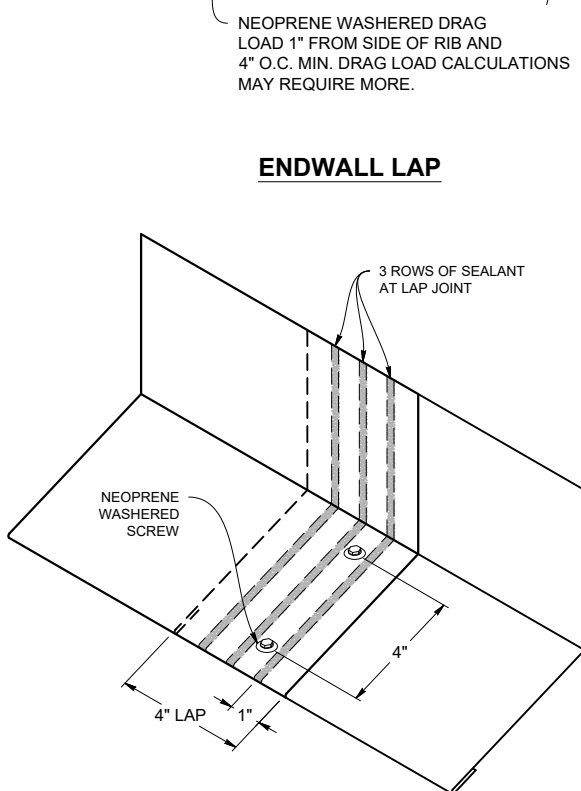

Note: All screws must be fastened into solid substrate.
Flashing must be lapped 4" with 3 rows of sealant.

Vented Endwall

WT VENTED ENDWALL DETAIL

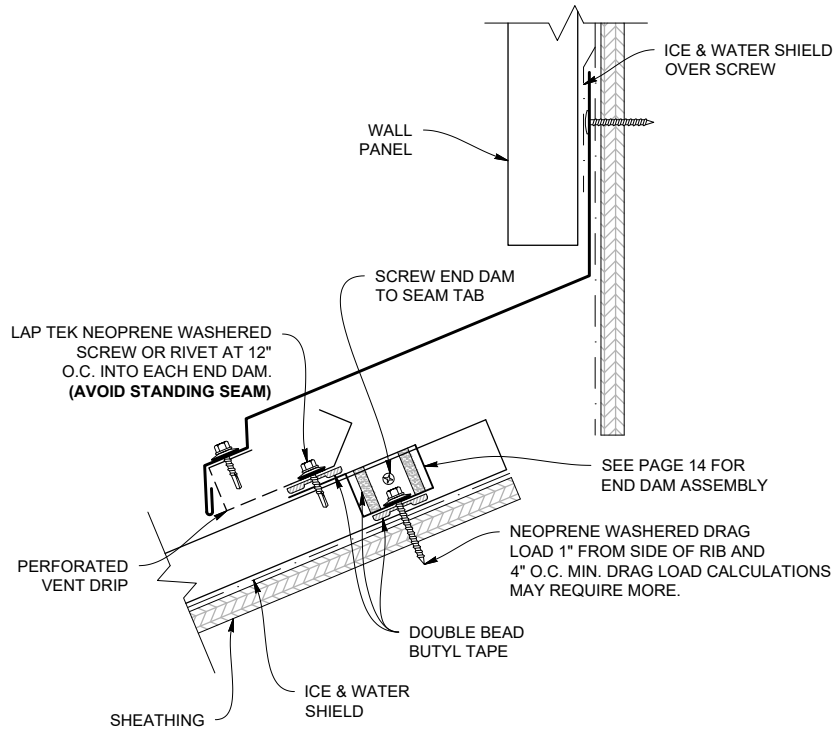

WT VENTED ENDWALL FLASHING (VSWTEWV)

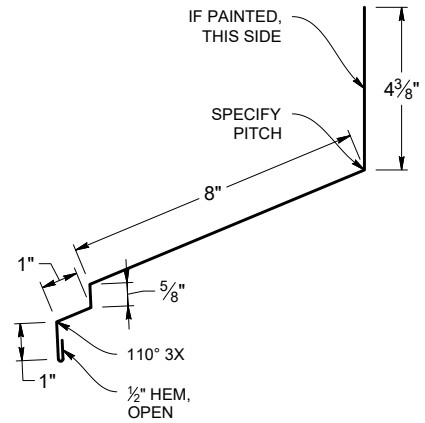

PERFORATED VENT DRIP (VSPVD)

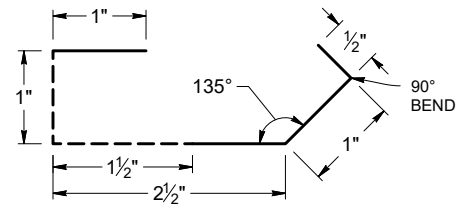

VENTED ENDWALL LAP

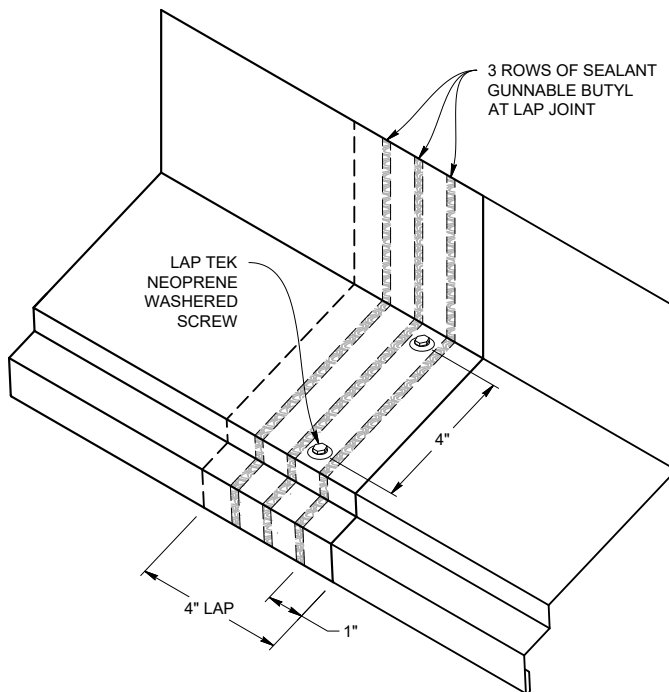

Note: All screws must be fastened into solid substrate.
Flashing must be lapped 4" with 3 rows of sealant.

SAW CUT ENDWALL DETAIL

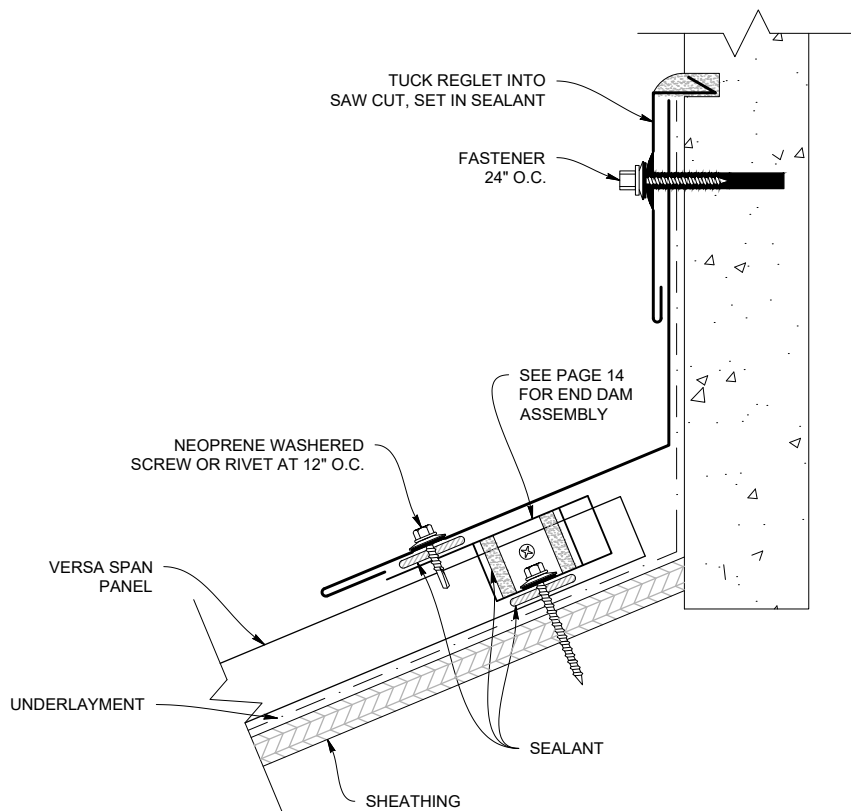

ENDWALL FLASHING (VSEWV)

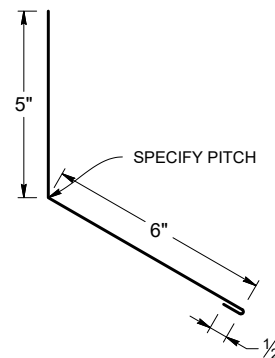

ENDWALL LAP

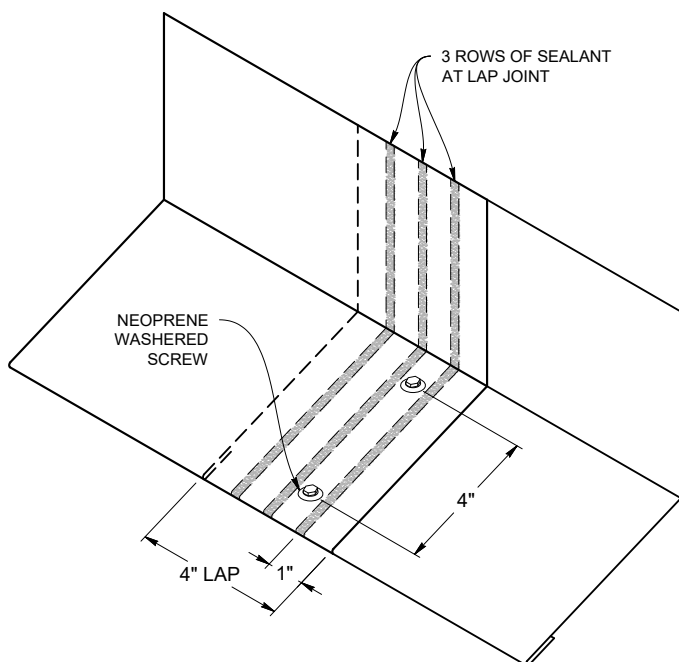

REGLET (VSRF)

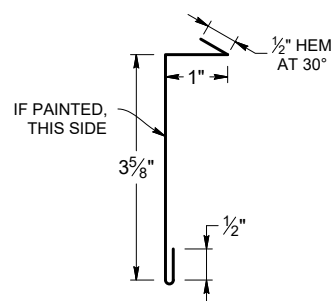

Note: All screws must be fastened into solid substrate.
Flashing must be lapped 4" with 3 rows of sealant.

Curb Back Pan/Cricket

STEP 1

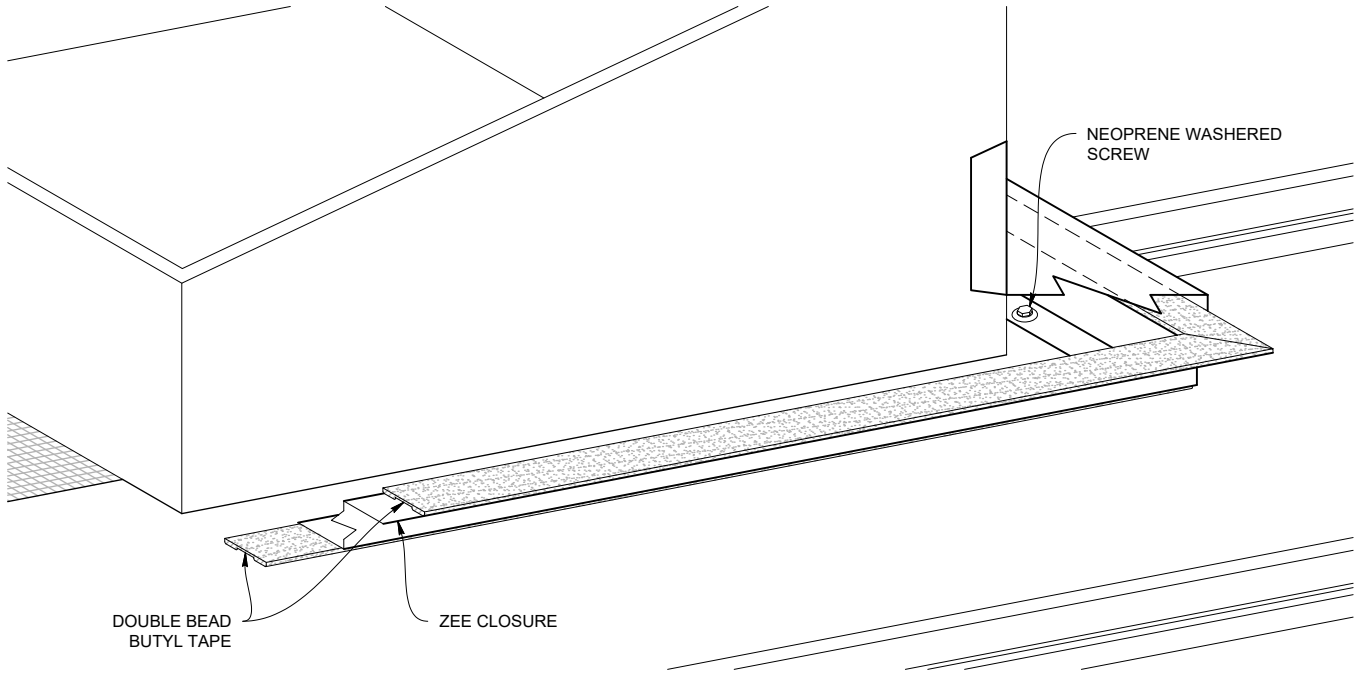

STEP 2

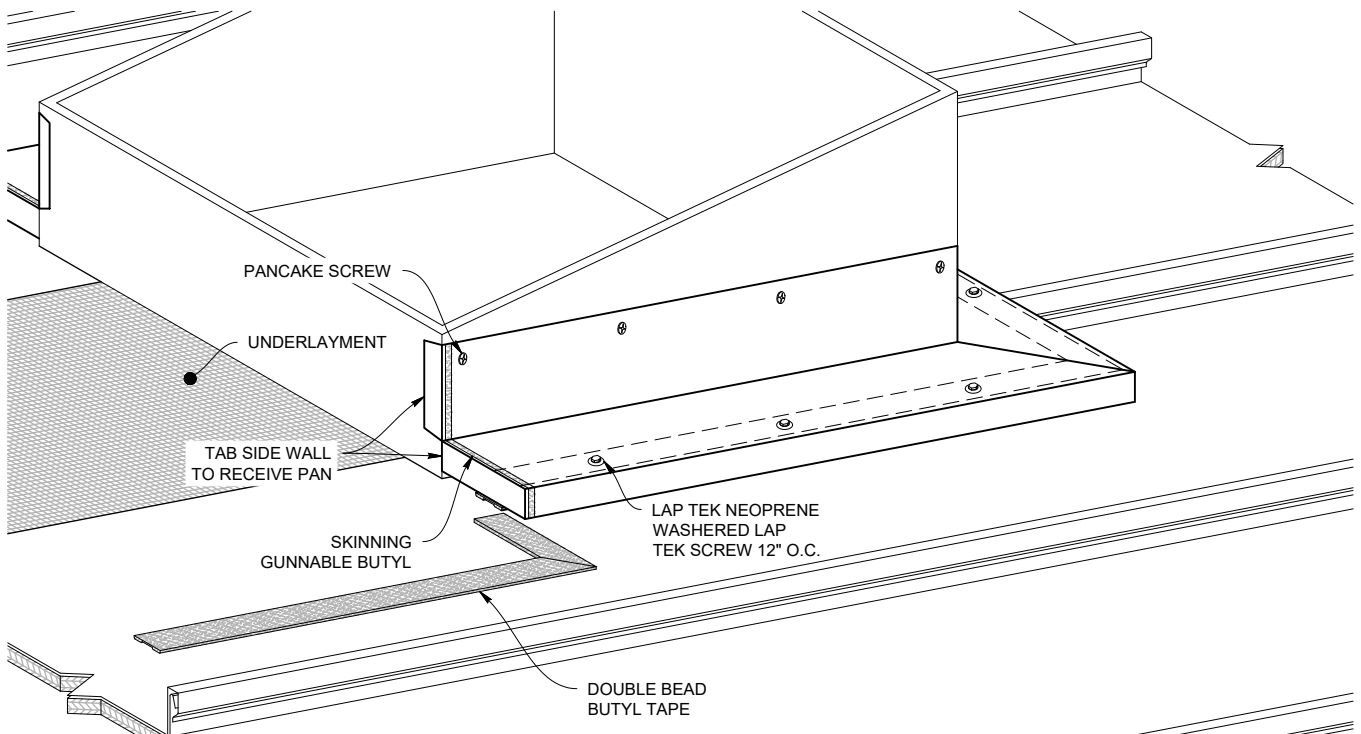

Note: All screws must be fastened into solid substrate.
Flashing must be lapped 4" with 3 rows of sealant.

STEP 3

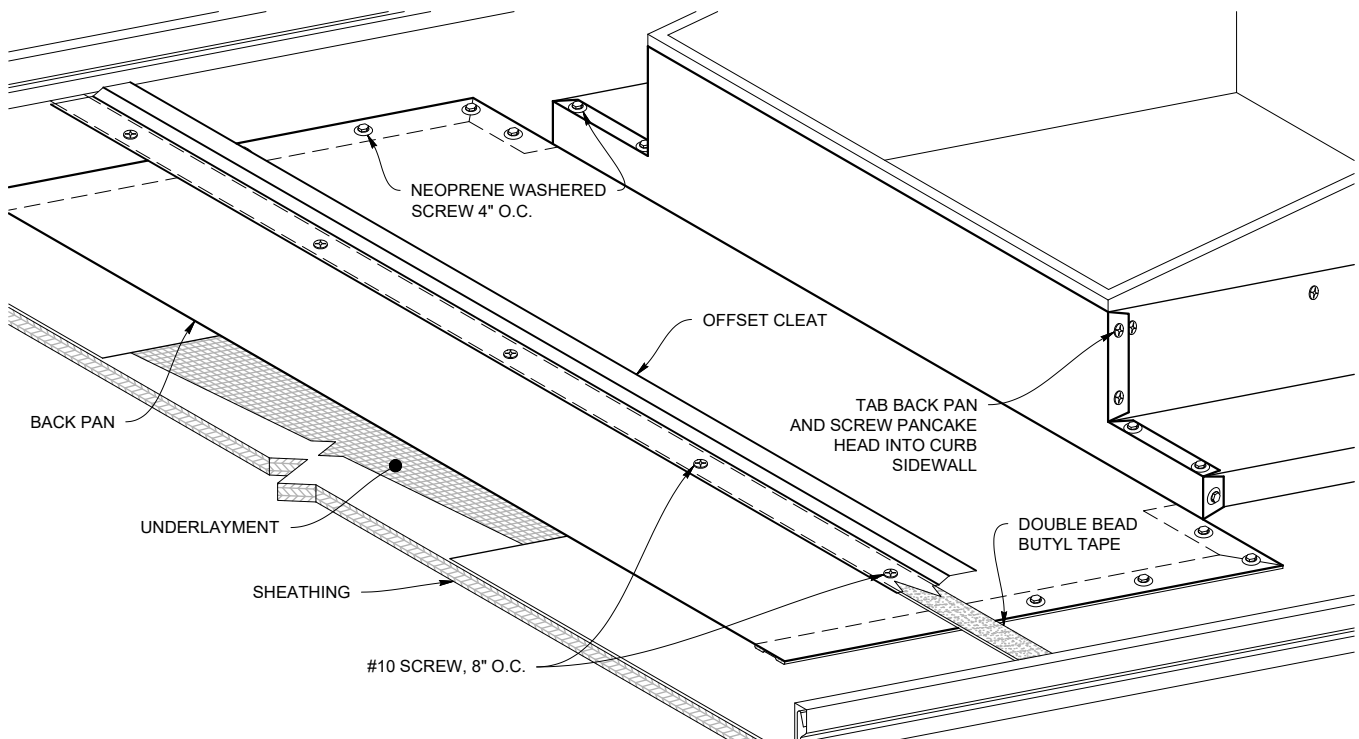

STEP 4

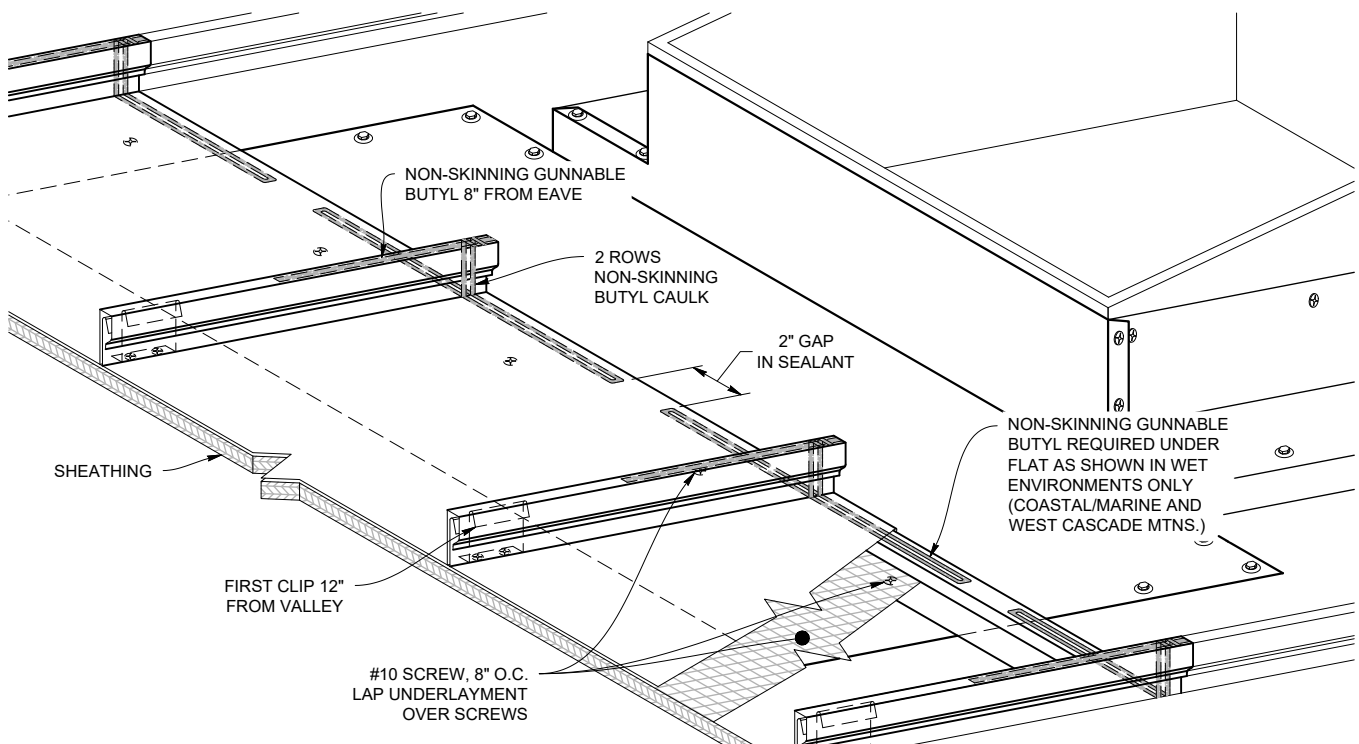

Note: All screws must be fastened into solid substrate.
Flashing must be lapped 4" with 3 rows of sealant.

Curb Back Pan/Cricket

STEP 5

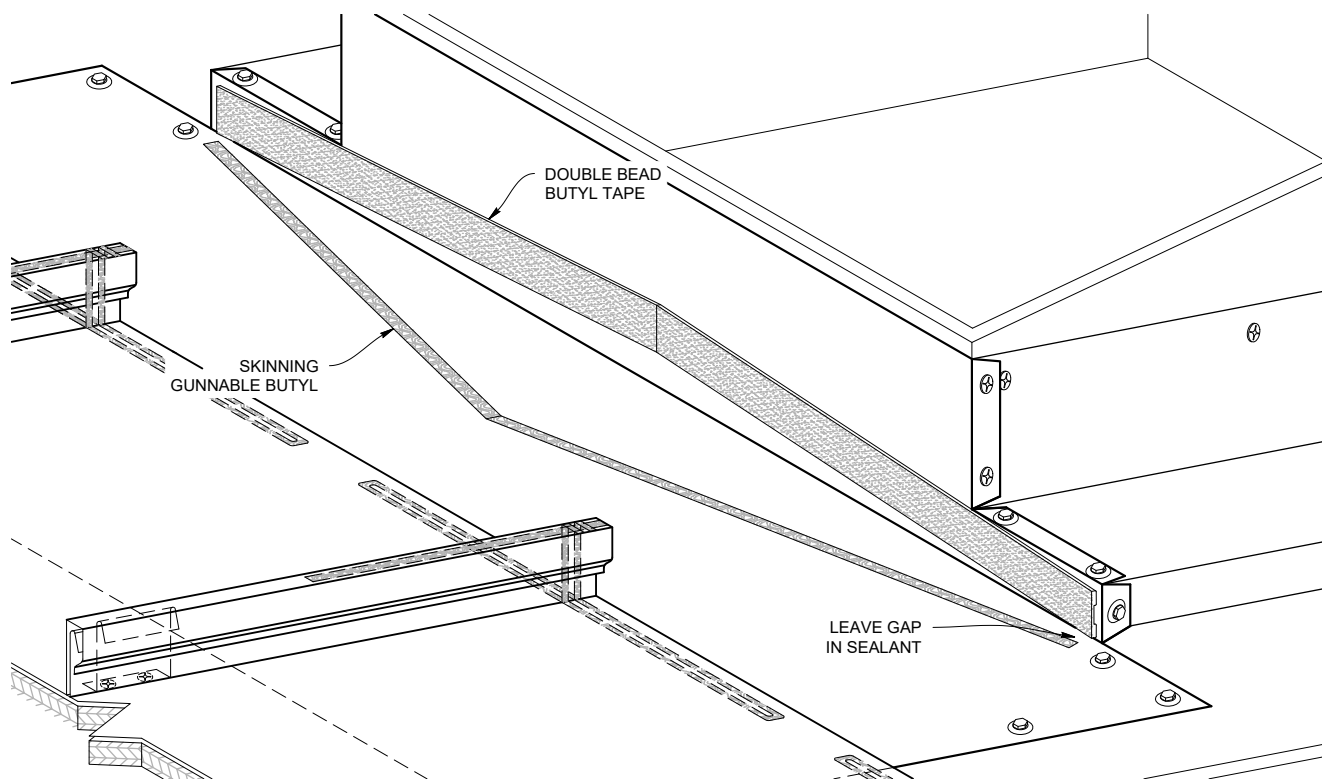

STEP 6

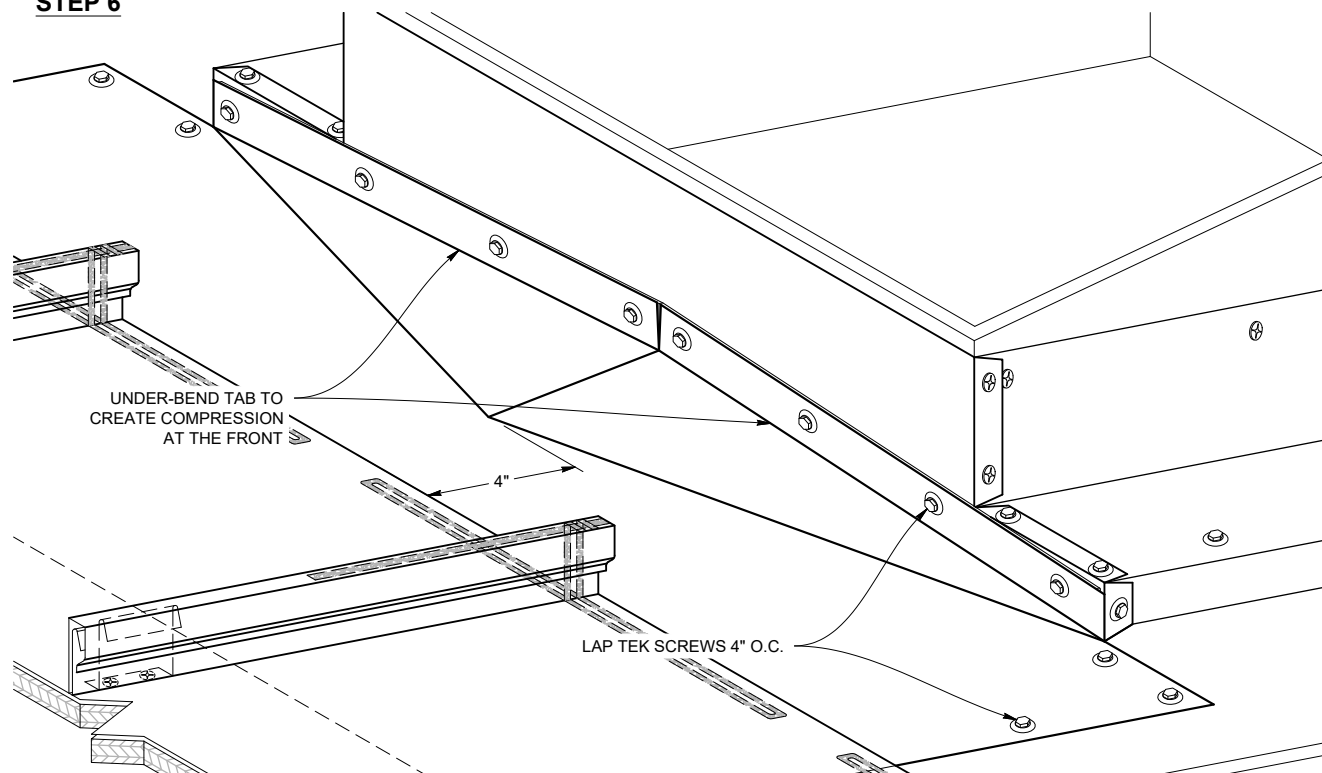

Note: All screws must be fastened into solid substrate.
Flashing must be lapped 4" with 3 rows of sealant.

CURB SIDEWALL DETAIL

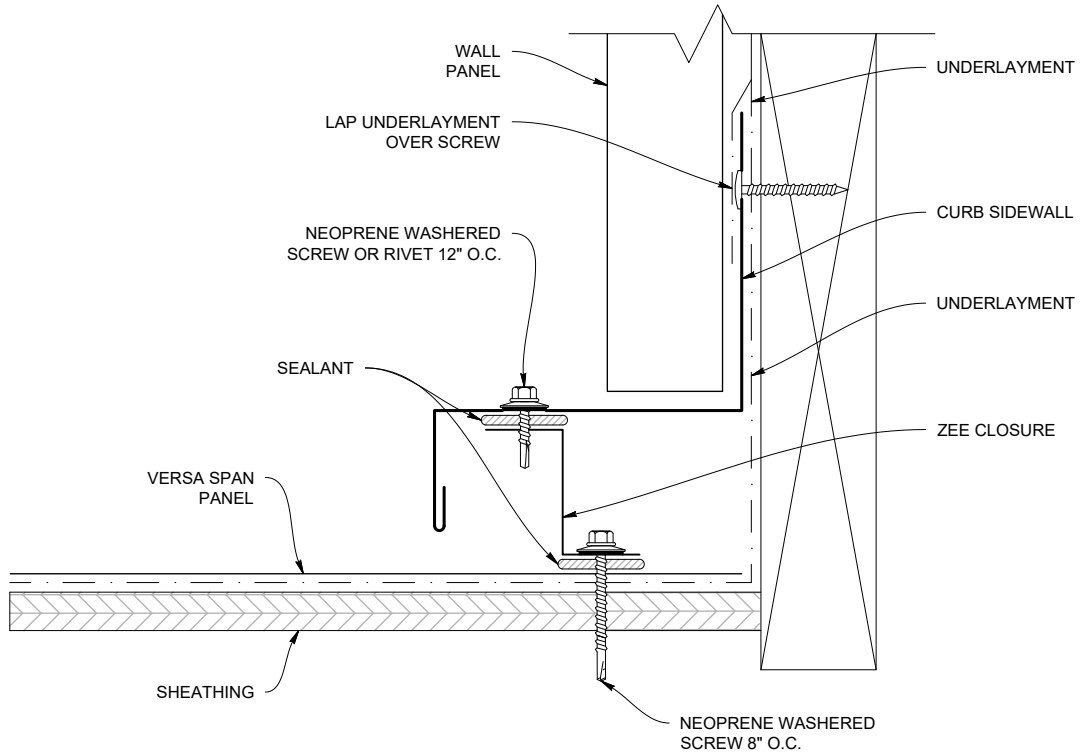

ZEE CLOSURE (VSZC)

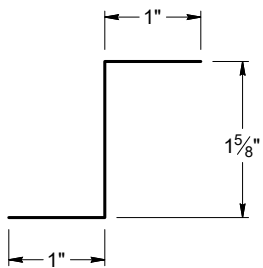

CURB SIDEWALL (VSCSW)

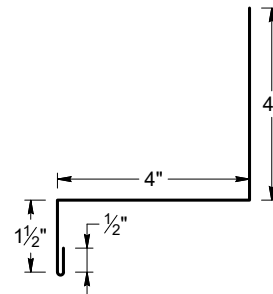

Note: All screws must be fastened into solid substrate.
Flashing must be lapped 4" with 3 rows of sealant.

Curb Endwall

CURB ENDWALL DETAIL

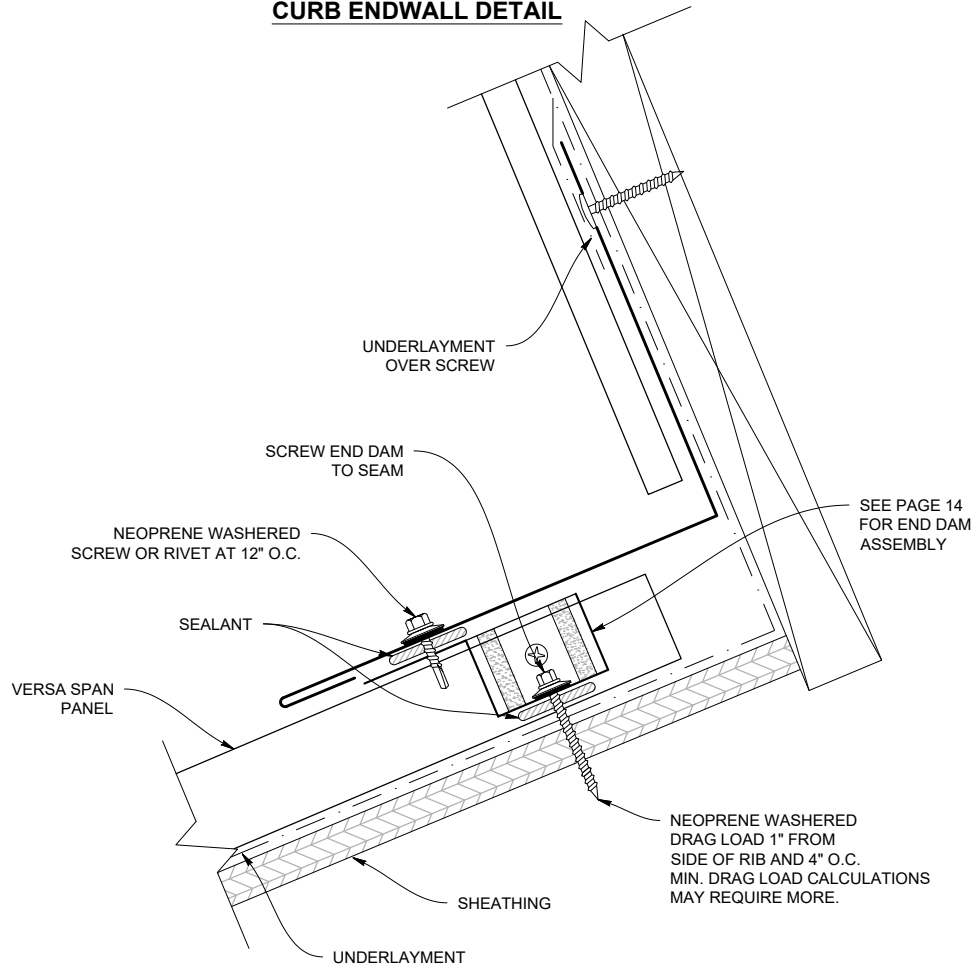

ENDWALL DETAIL

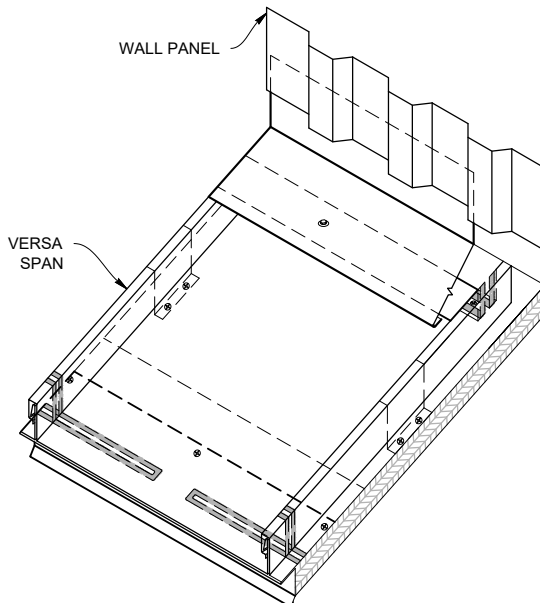

CURB SIDEWALL (VSCSW)

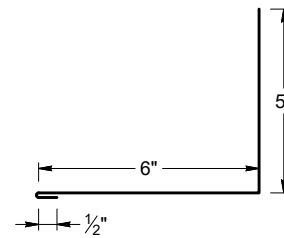

Note: All screws must be fastened into solid substrate.
Flashing must be lapped 4" with 3 rows of sealant.

CURB BACK PAN / CRICKET DETAIL (2:12 Pitch or Greater)

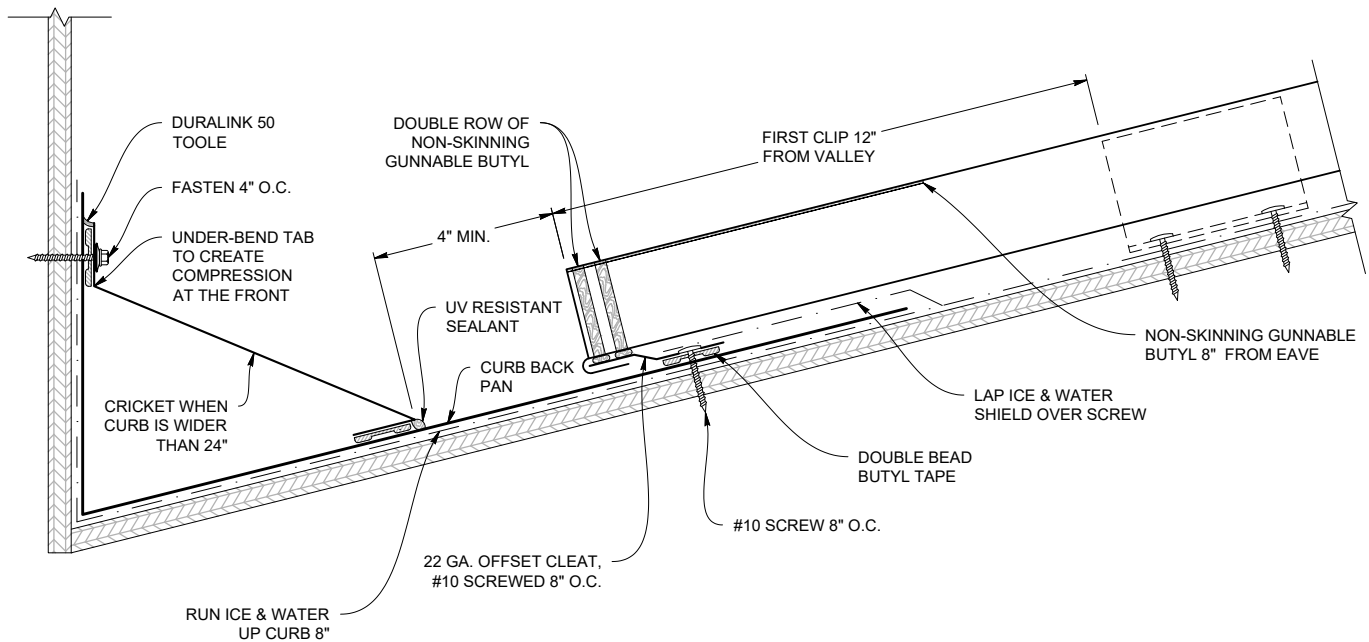

CURB BACK PAN / CRICKET DETAIL (Less Than 2:12 Pitch - Not recommended)

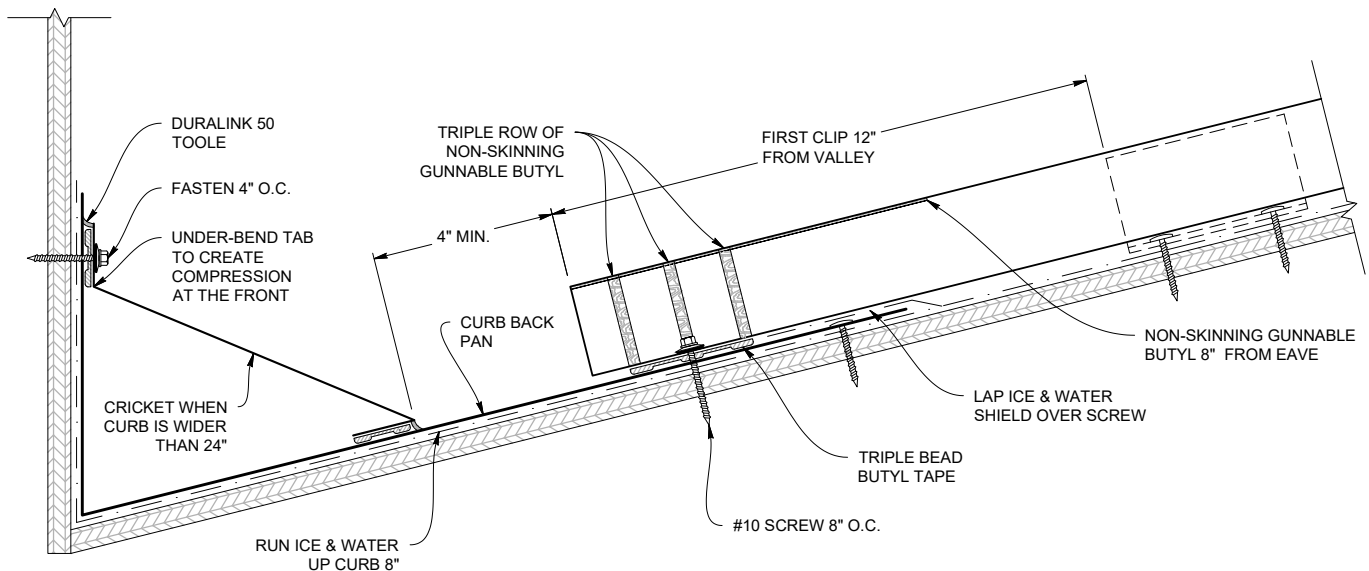

Note: All screws must be fastened into solid substrate.
Flashing must be lapped 4" with 3 rows of sealant.

Eave to Gable Transition

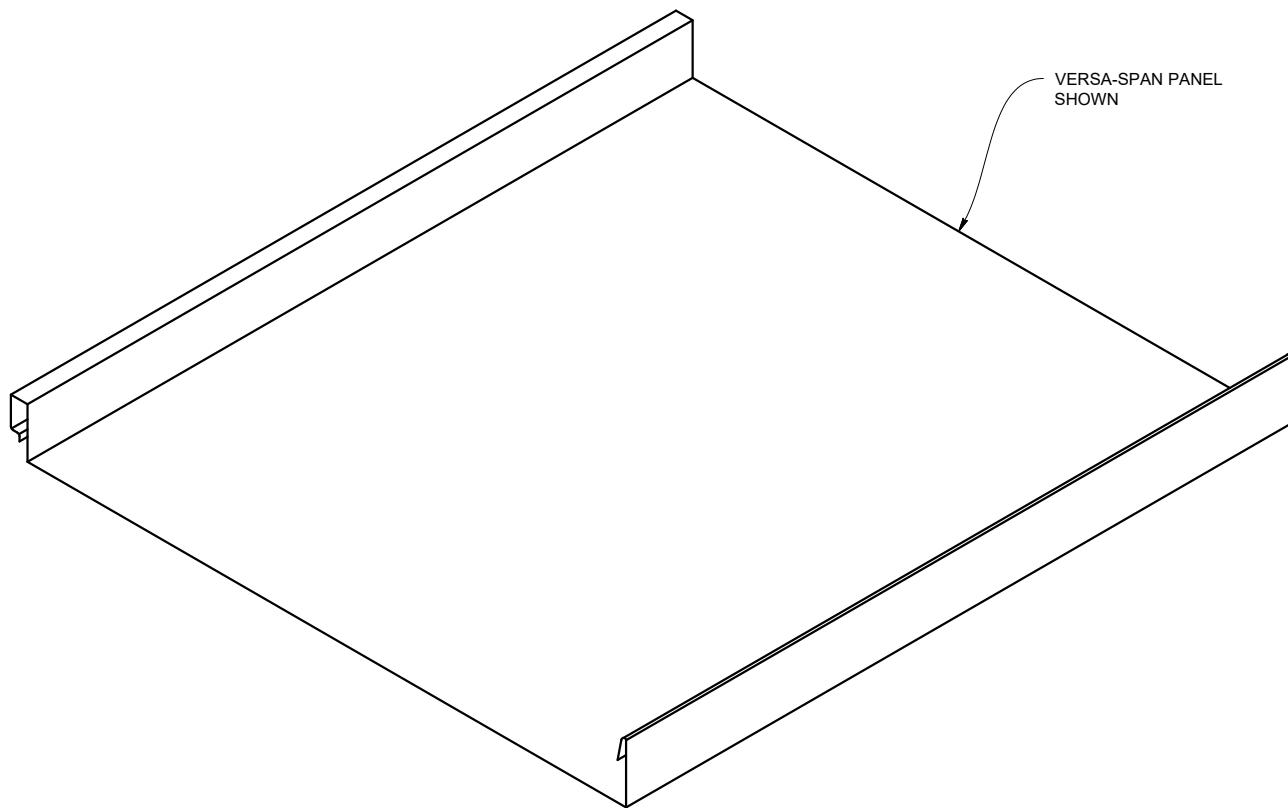

STEP 1

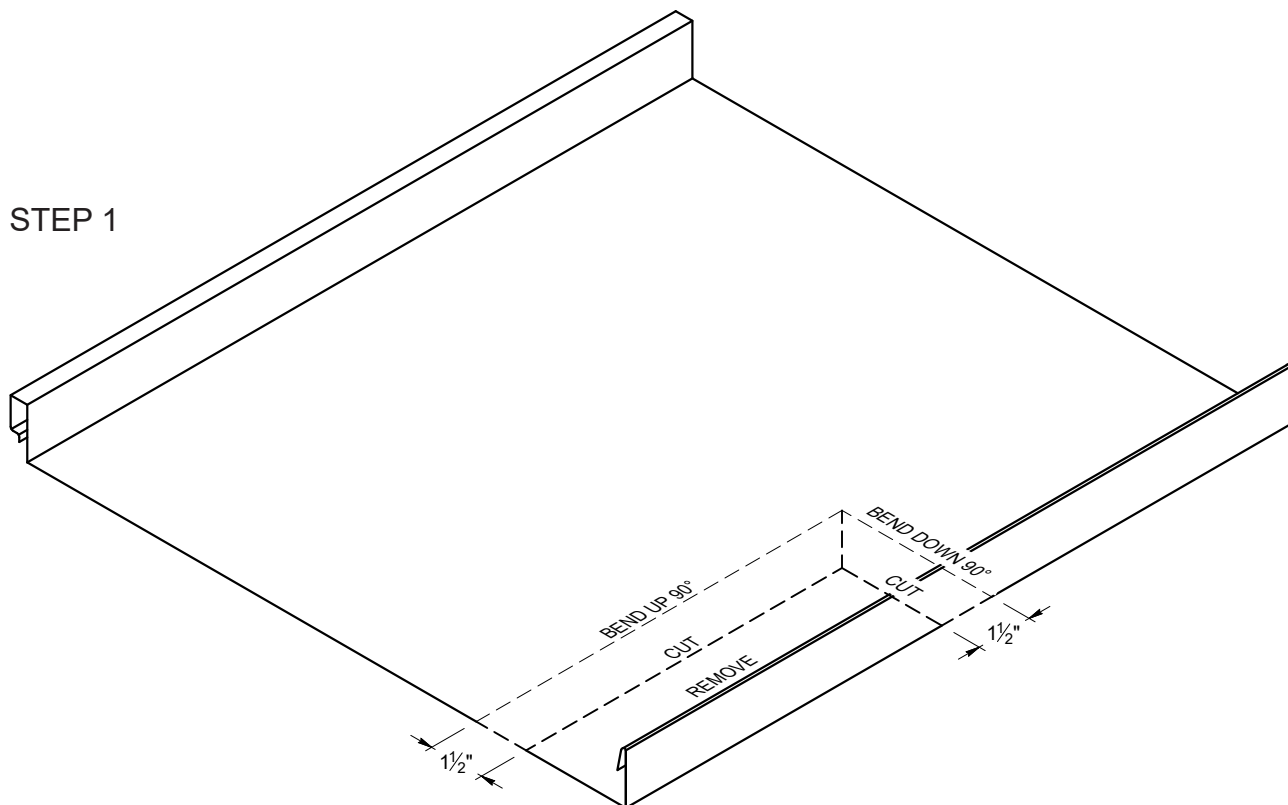

Note: All screws must be fastened into solid substrate.
Flashing must be lapped 4" with 3 rows of sealant.

STEP 2

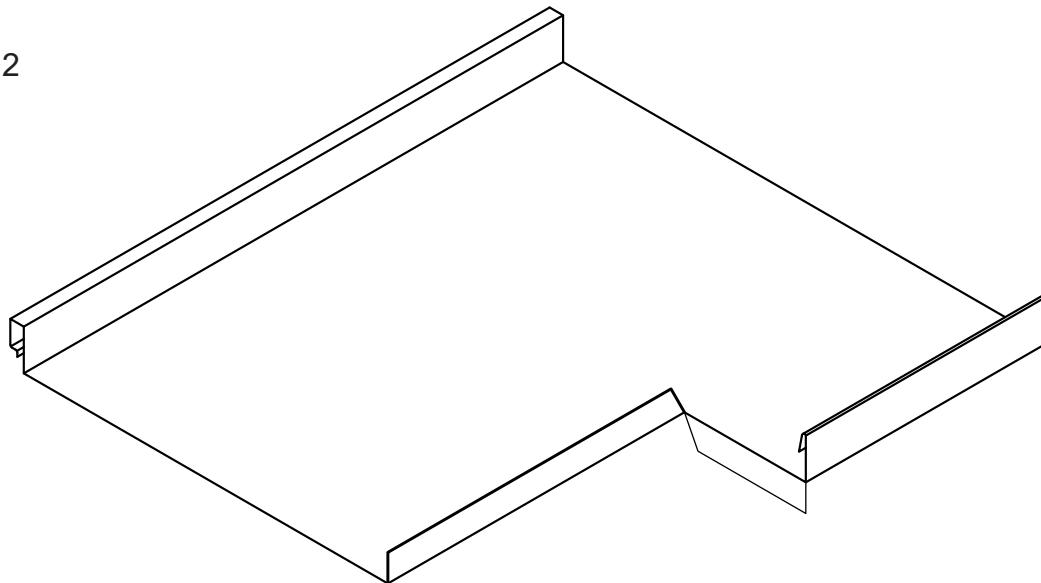

STEP 3

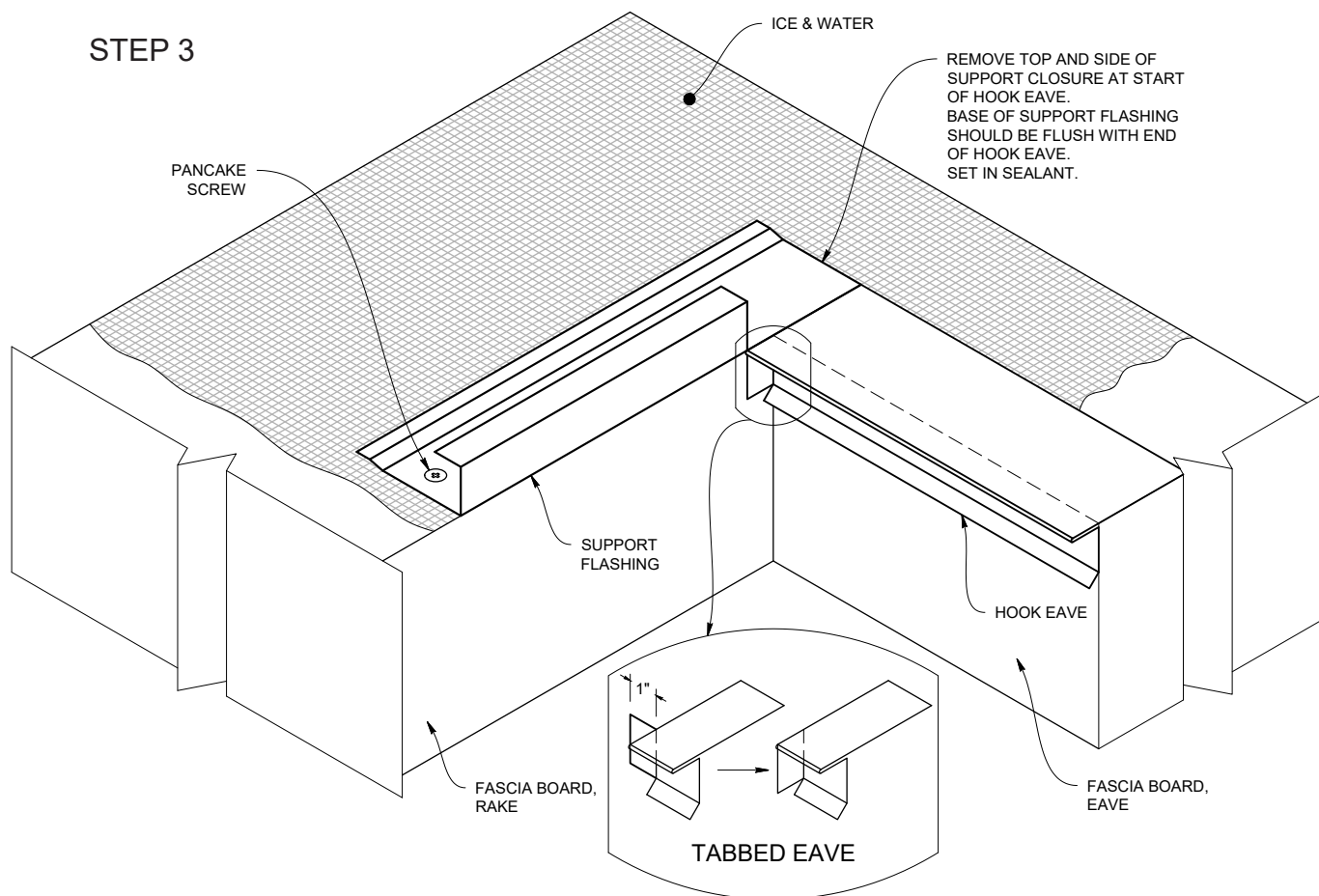

Note: All screws must be fastened into solid substrate.
Flashing must be lapped 4" with 3 rows of sealant.

Eave to Gable Transition

STEP 4

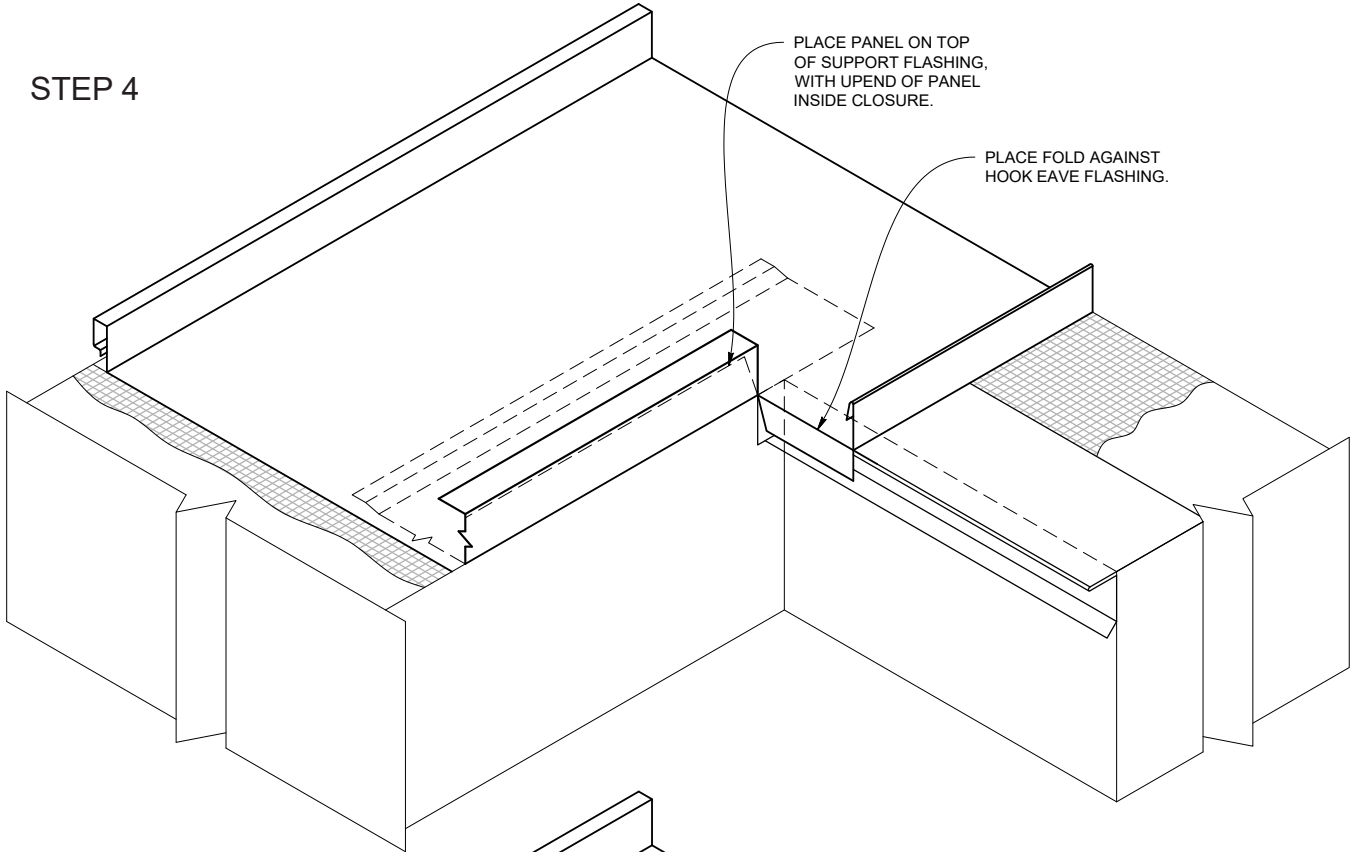

STEP 5

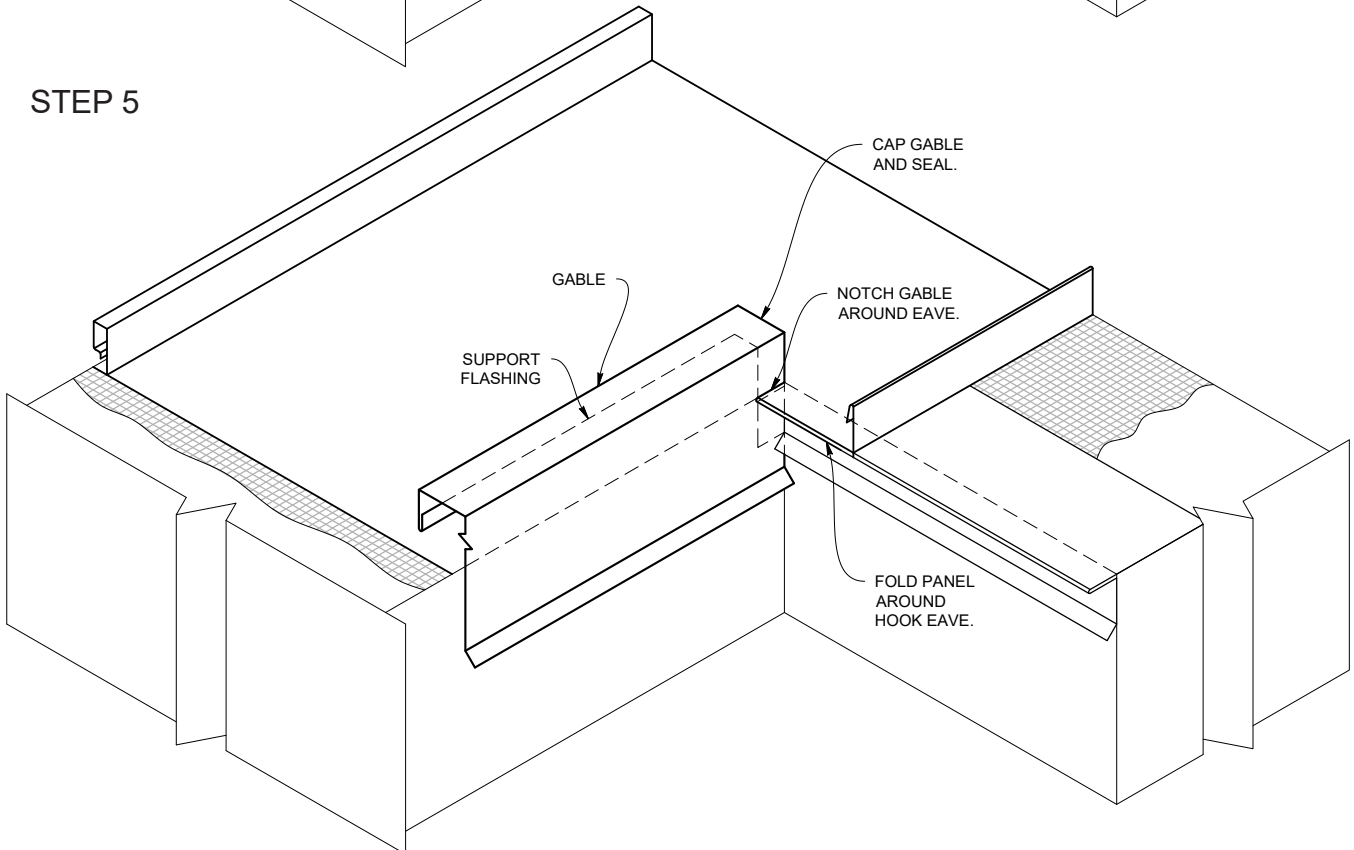

Note: All screws must be fastened into solid substrate.
Flashing must be lapped 4" with 3 rows of sealant.

FOR PIPES LOCATED OVER 20' FROM PIN POINT

(Allows panel and pipe flashing to move with temperature change.)

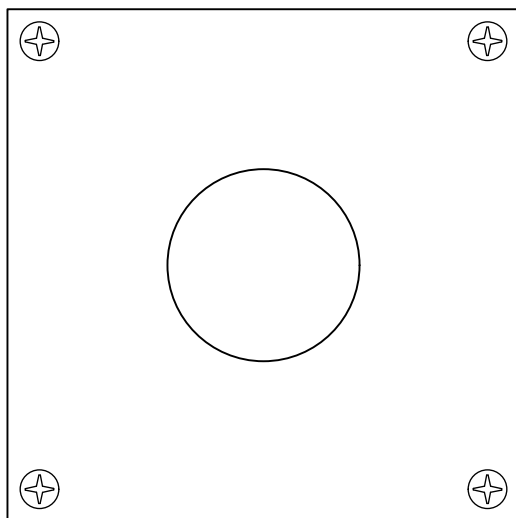
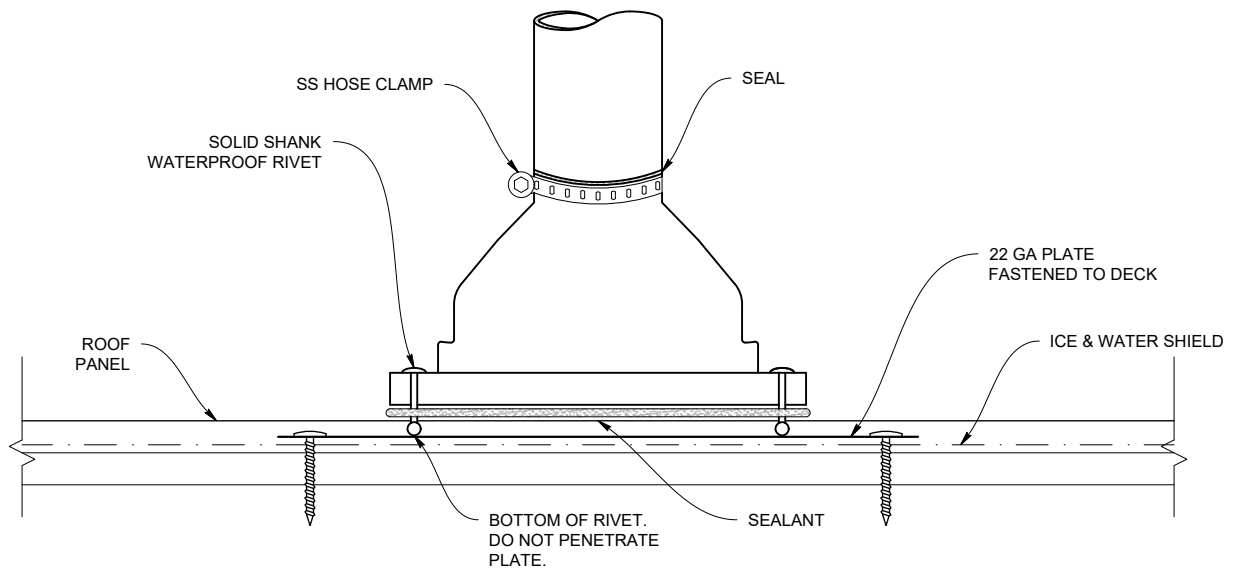

SINGLE 22 GAUGE PLATE

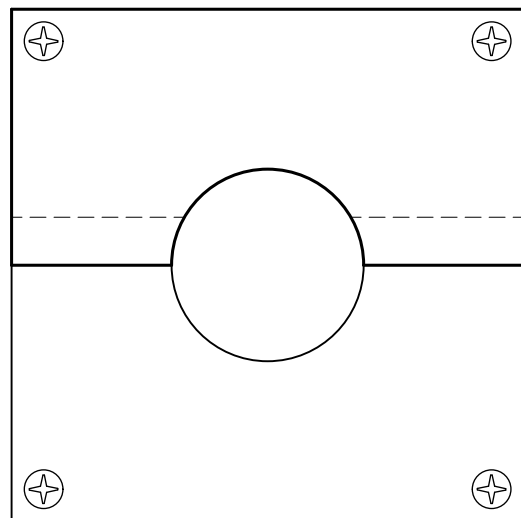

TWO OVERLAPPING 22 GAUGE PLATES

Note: All screws must be fastened into solid substrate.
Flashing must be lapped 4" with 3 rows of sealant.

Pipe Penetration - on Rib

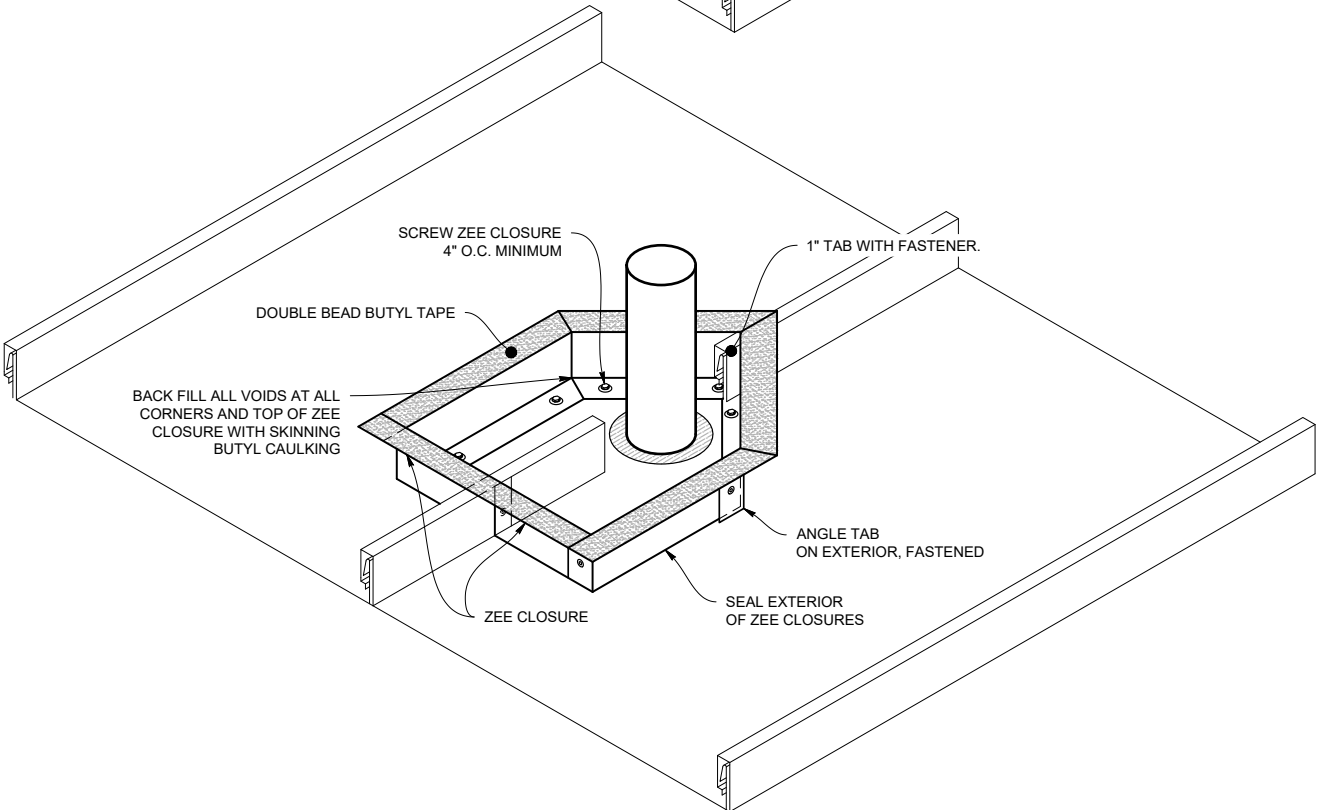
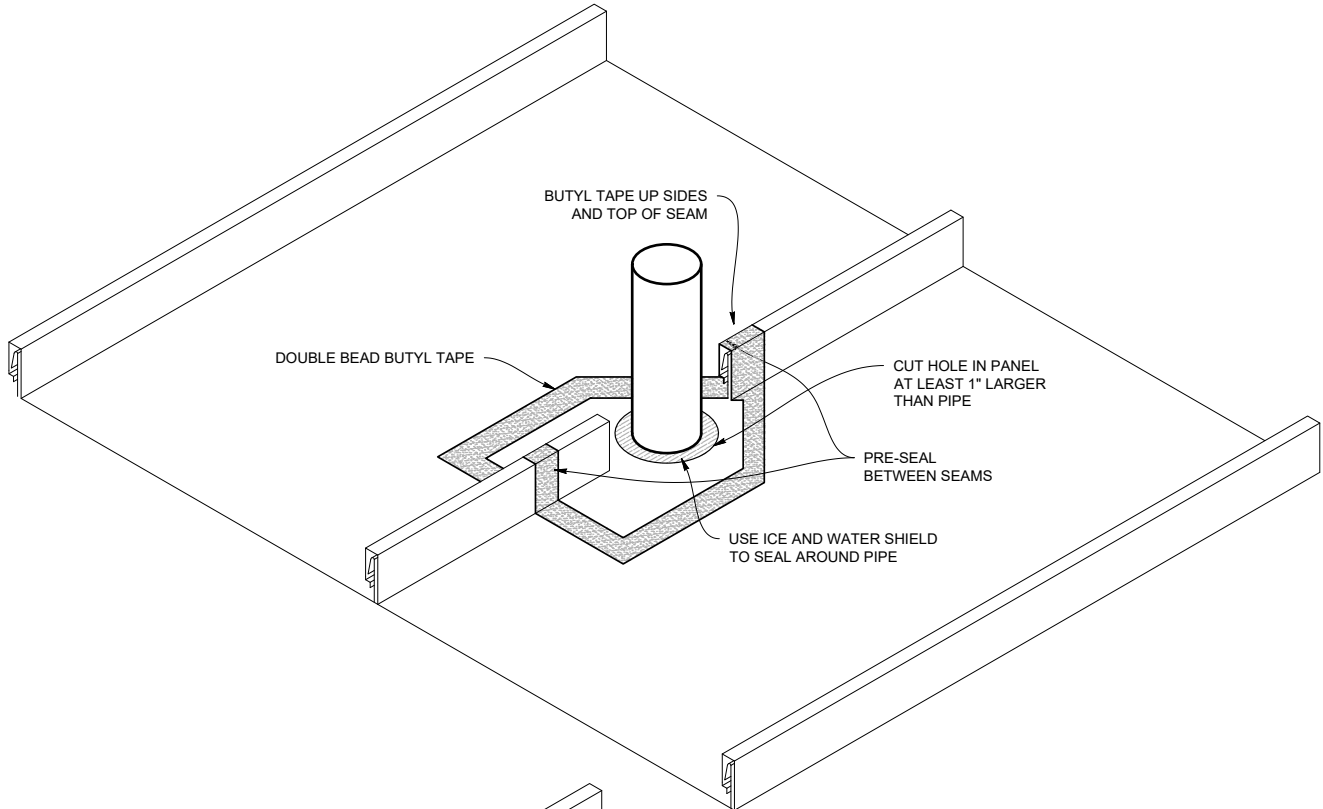

Note: All screws must be fastened into solid substrate.
Flashing must be lapped 4" with 3 rows of sealant.

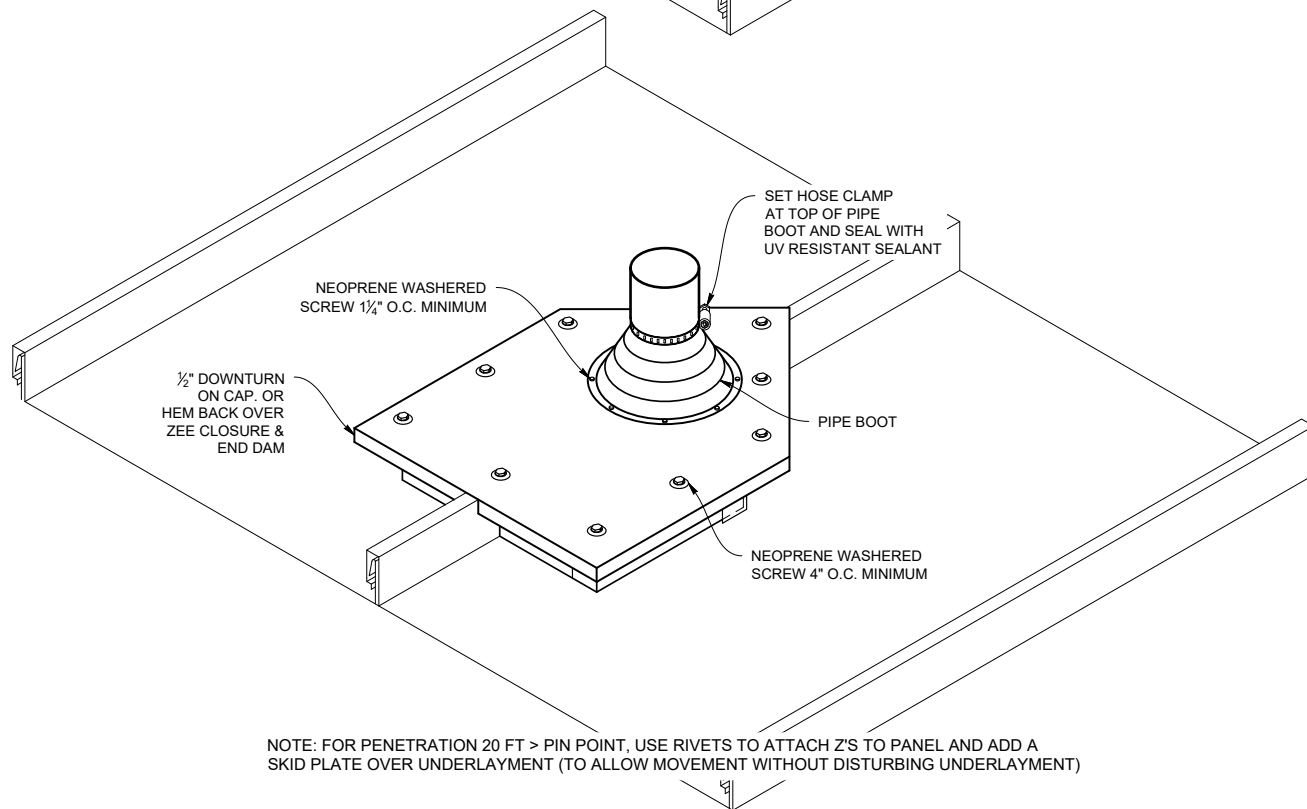
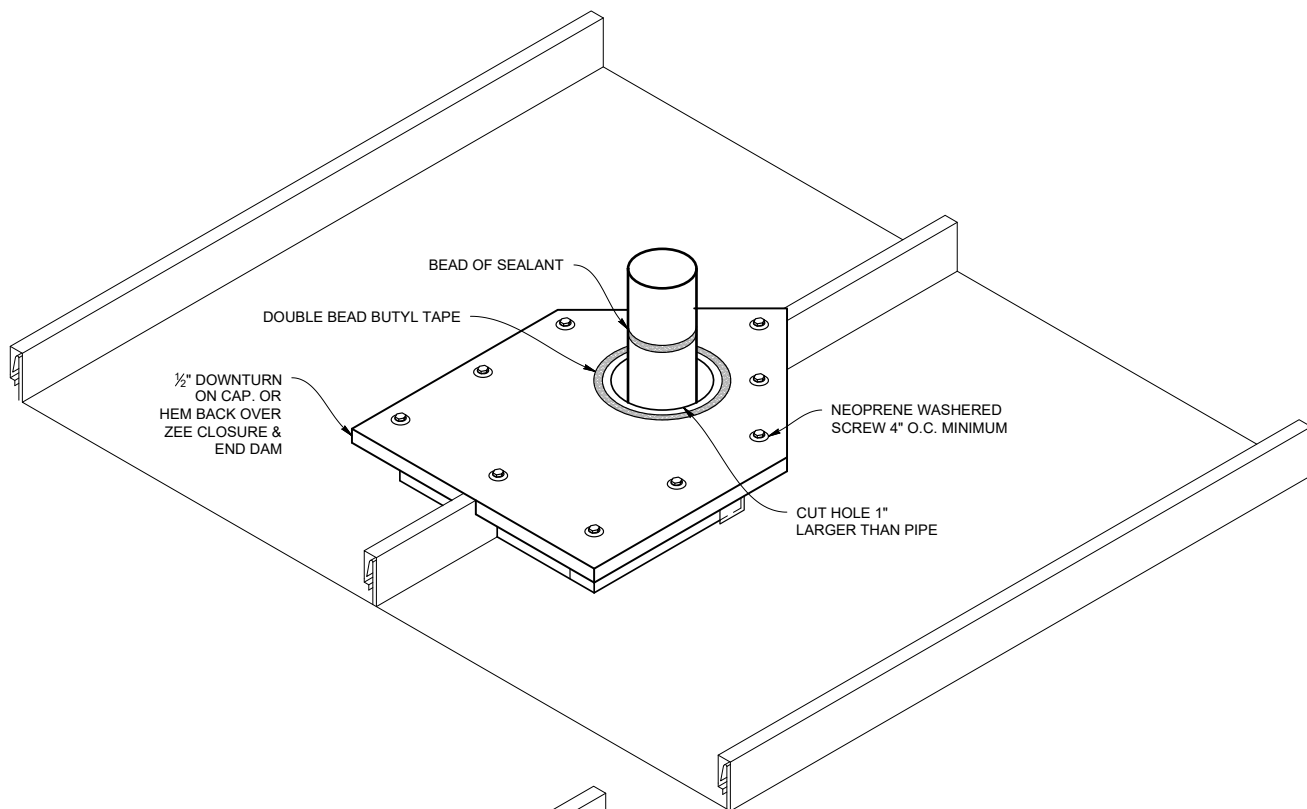

NOTE: FOR PENETRATION 20 FT > PIN POINT, USE RIVETS TO ATTACH Z'S TO PANEL AND ADD A SKID PLATE OVER UNDERLAYMENT (TO ALLOW MOVEMENT WITHOUT DISTURBING UNDERLAYMENT)

Note: All screws must be fastened into solid substrate.
Flashing must be lapped 4" with 3 rows of sealant.

Pipe Penetration - on Pan

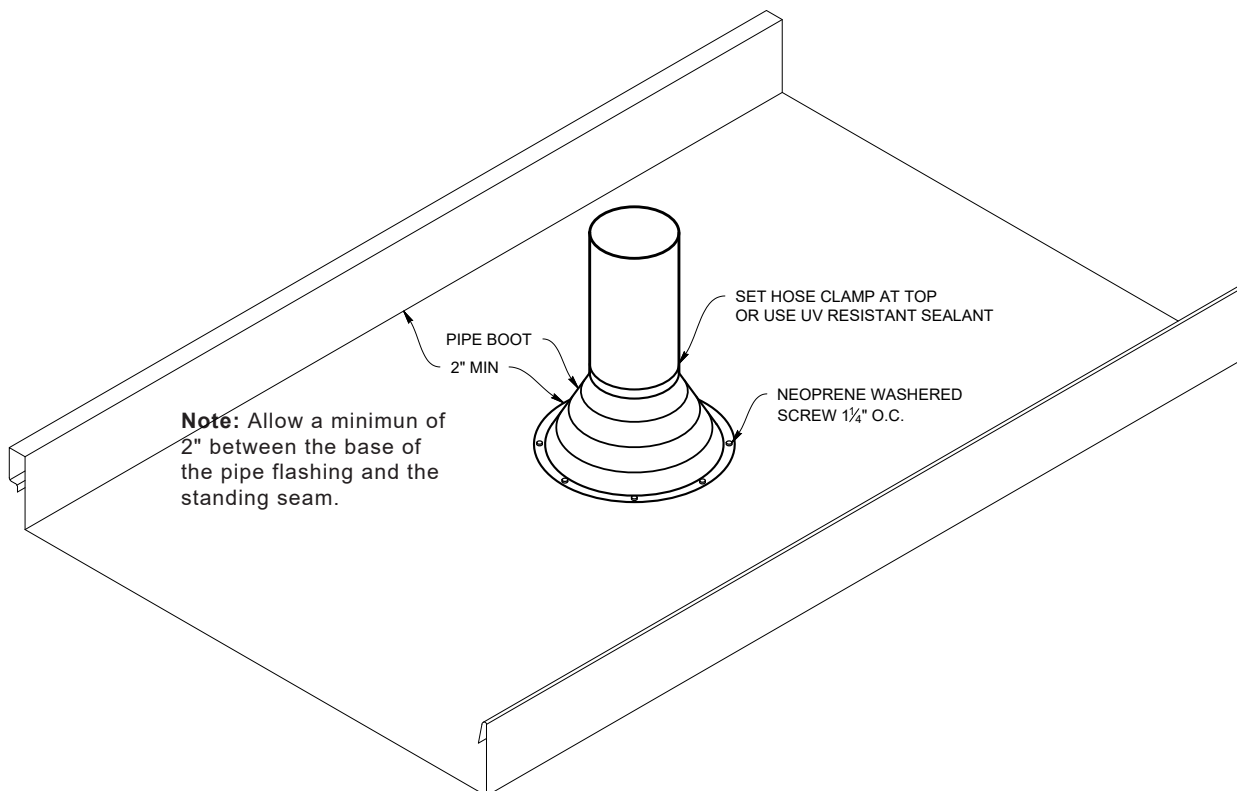
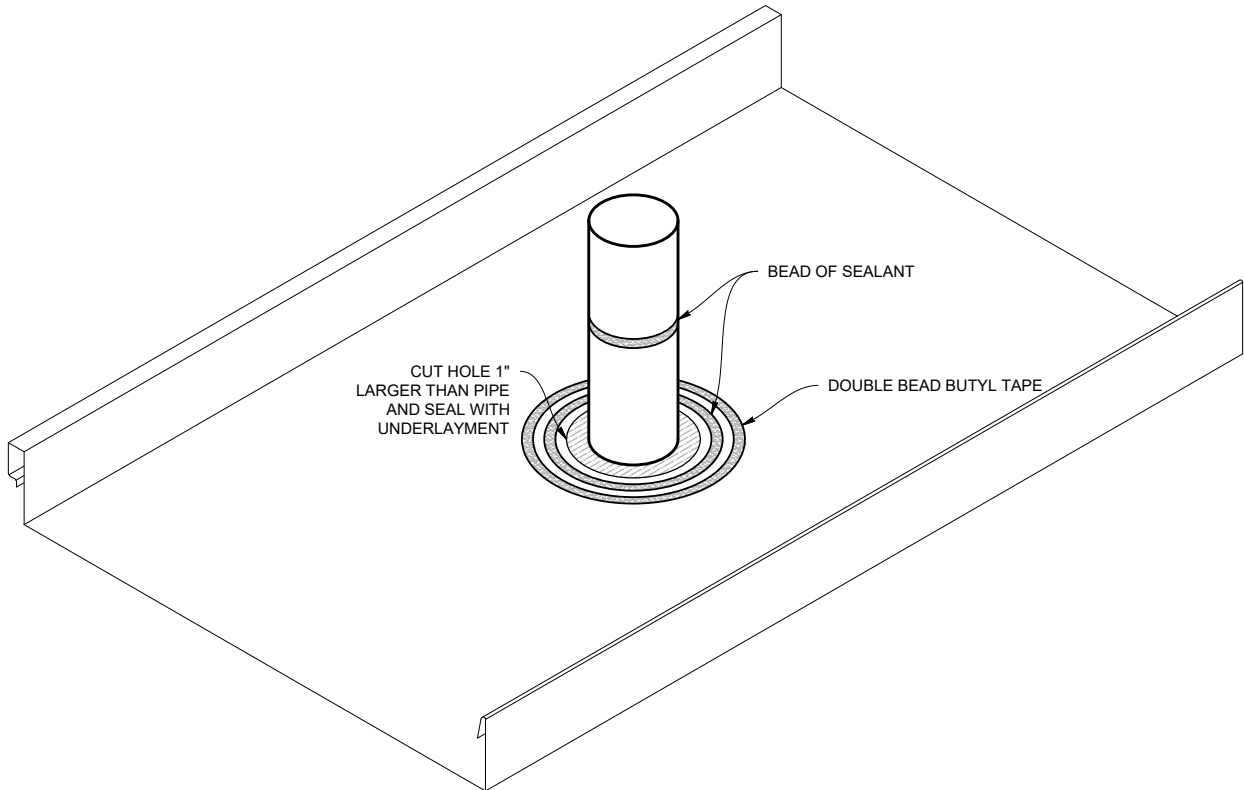

Note: All screws must be fastened into solid substrate.
Flashing must be lapped 4" with 3 rows of sealant.

EAVE STANDARD
(VSES)

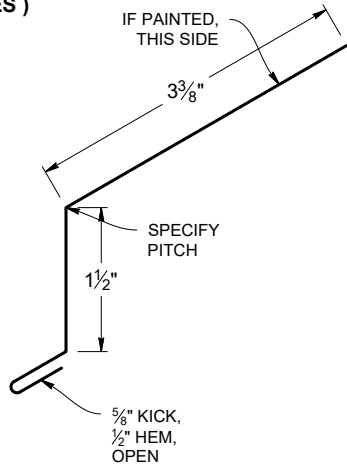

SCALE 1:2 S.O. 6" WEIGHT: 4.9 LBS.

EAVE HOOK
(VSEH)

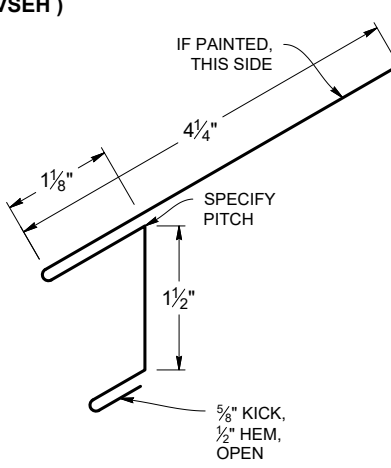

SCALE 1:2 S.O. 8" WEIGHT: 6.5 LBS.

OFFSET CLEAT
(VSOC)

NON-VISIBLE / SUB-FLASHINGS ARE NOT PROVIDED IN SPECIFIC COLORS UNLESS SPECIFIED

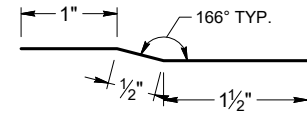

SCALE 1:2 S.O. 3" WEIGHT: 2.5 LBS.

GUTTER HANGER
(AGH6)

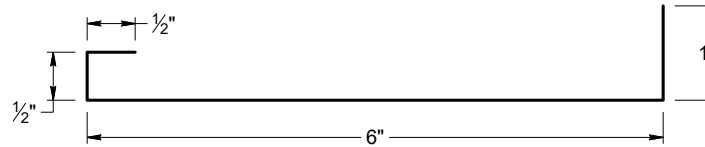

S.O. 8"

WEIGHT: 6.5 LBS.

SCALE 1:2

BOX GUTTER
(VSBG)

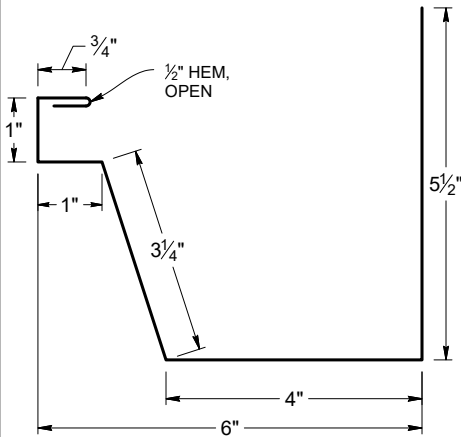

SCALE 1:3 S.O. 16" WEIGHT: 13.1 LBS.

STANDARD GABLE
(VSGS)

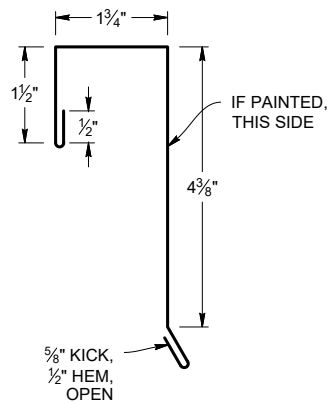

SCALE 1:3 S.O. 9.25" WEIGHT: 7.5 LBS.

GABLE SUPPORT CLEAT
(VSGC)

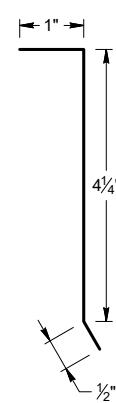

SCALE 1:3 S.O. 5.75" WEIGHT: 4.7 LBS.

<p>ALTERNATE GABLE (VSAG)</p> <p>IF PAINTED, THIS SIDE</p> <p>5/8" KICK, 1/2" HEM, OPEN</p> <p>SCALE 1:3 S.O. 8.5" WEIGHT: 7 LBS.</p>	<p>ALTERNATE GABLE CLEAT (VSAGC)</p> <p>IF PAINTED, THIS SIDE</p> <p>*FOR USE WITH ALTERNATE GABLE ONLY</p> <p>SCALE 1:3 S.O. 8.625" WEIGHT: 7 LBS.</p>	<p>SUPPORT FLASHING (VSSF)</p> <p>NON-VISIBLE / SUB-FLASHINGS ARE NOT PROVIDED IN SPECIFIC COLORS UNLESS SPECIFIED</p> <p>SCALE 1:3 S.O. 6.875" WEIGHT: 5.6 LBS.</p>
<p>PEAK FLASHING (RIDGE END CAP) (VSREC)</p> <p>IF PAINTED, THIS SIDE</p> <p>SPECIFY PITCH</p> <p>1" HEM, OPEN</p> <p>5/8" KICK, 1/2" HEM, OPEN</p> <p>SCALE 1:4 S.O. 14.5" WEIGHT: 11.8 LBS.</p>	<p>WT VENTED PEAK FLASHING (VSWTREC)</p> <p>IF PAINTED, THIS SIDE</p> <p>SPECIFY PITCH</p> <p>110°</p> <p>1" HEM, OPEN</p> <p>5/8" KICK, 1/2" HEM, OPEN</p> <p>SCALE 1:4 S.O. 18.25" WEIGHT: 14.85 LBS.</p>	<p>PEAK CLEAT / VENTED PEAK CLEAT (VSRECC / VSVRECC)</p> <p>NON-VISIBLE / SUB-FLASHINGS ARE NOT PROVIDED IN SPECIFIC COLORS UNLESS SPECIFIED</p> <p>SPECIFY PITCH</p> <p>5 1/4" PEAK CLEAT 5 7/8" VENTED PEAK CLEAT</p> <p>SCALE 1:3 S.O. 6.75" / 7.375" WEIGHT: 5.5 LBS.</p>
<p>STANDARD RIDGE (VSRS)</p> <p>IF PAINTED, THIS SIDE</p> <p>SPECIFY PITCH</p> <p>1" HEM, OPEN</p> <p>SCALE 1:4 S.O. 16" WEIGHT: 13.1 LBS.</p>	<p>WT RIDGE VENTED (VSWTRFV)</p> <p>IF PAINTED, THIS SIDE</p> <p>SPECIFY PITCH</p> <p>110°</p> <p>1" HEM, OPEN</p> <p>5/8" KICK, 1/2" HEM, OPEN</p> <p>SCALE 1:6 S.O. 22.25" WEIGHT: 18.1 LBS.</p>	

**VALLEY WIDE FLASHING
(VSVFW)**

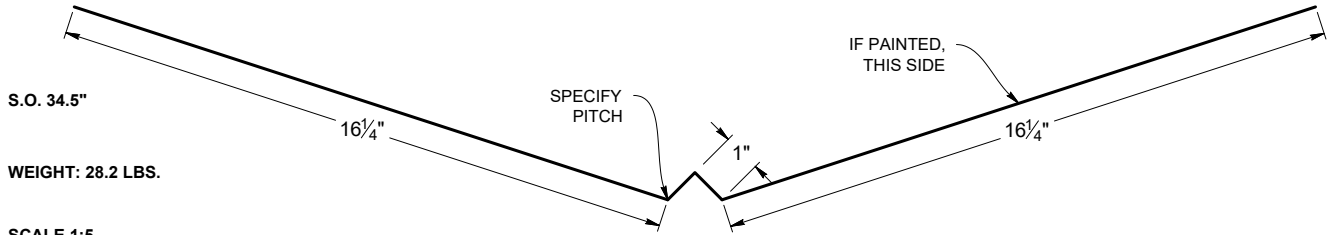

WEIGHT: 28.2 LBS.

SCALE 1:5

**VALLEY FLASHING
(VSVF)**

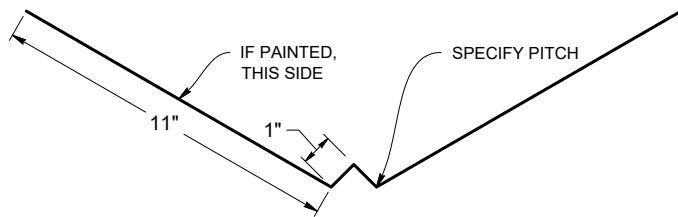

SCALE 1:6

S.O. 24"

WEIGHT: 19.7 LBS.

**OFFSET CLEAT
(VSOC)**

NON-VISIBLE / SUB-FLASHINGS
ARE NOT PROVIDED IN SPECIFIC
COLORS UNLESS SPECIFIED

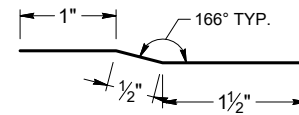

SCALE 1:2

S.O. 3"

WEIGHT: 2.5 LBS.

**CURB SIDEWALL
(VSCSW)**

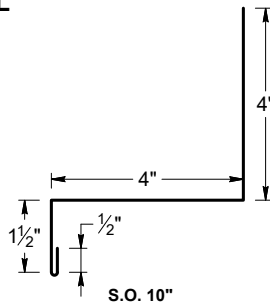

SCALE 1:4

S.O. 10"

WEIGHT: 8.2 LBS.

**SIDEWALL
(VSSW)**

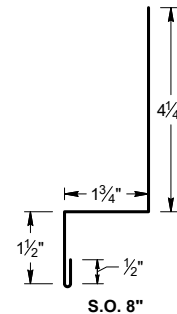

SCALE 1:4

S.O. 8"

WEIGHT: 6.6 LBS.

**ENDWALL
(VSEW)**

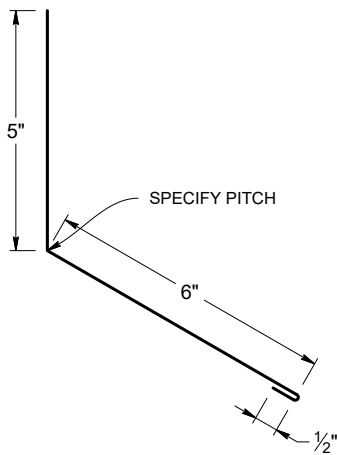

SCALE 1:4

S.O. 11.5"

WEIGHT: 9.8 LBS.

**WT VENTED ENDWALL
(VSWTEWW)**

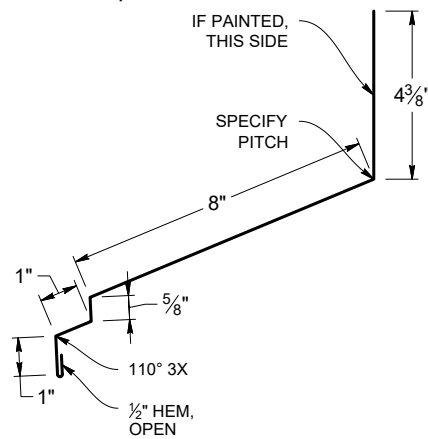

SCALE 1:4

S.O. 15.5"

WEIGHT: 12.6 LBS.

**CURB ENDWALL
(VSCH)**

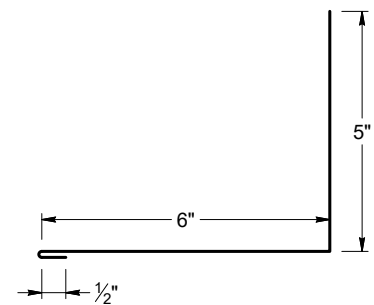

SCALE 1:4

S.O. 11.5"

WEIGHT: 9.8 LBS.

**BACK PAN
(VSPAN)**

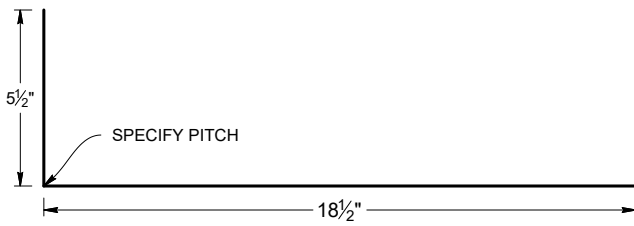

SCALE 1:4 S.O. 24" WEIGHT: 21.3 LBS.

**REGLET
(VSRF)**

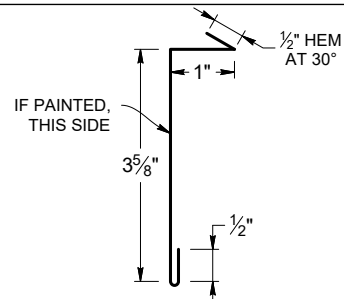

SCALE 1:3 S.O. 5.625" WEIGHT: 4.6 LBS.

VERSA-SPAN END DAM

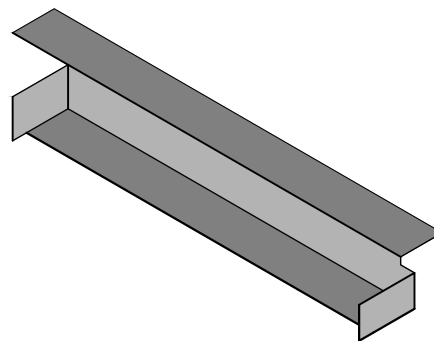

S.O. VARIES

WEIGHT: VARIES

**PERFORATED VENT DRIP
(VSPVD)**

NON-VISIBLE / SUB-FLASHINGS
ARE NOT PROVIDED IN SPECIFIC
COLORS UNLESS SPECIFIED

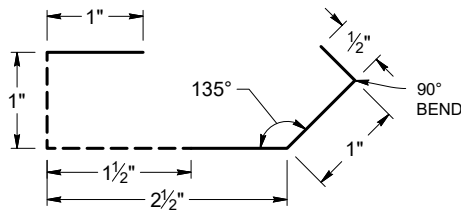

SCALE 1:2 S.O. 6" WEIGHT: 4.9 LBS.

**ZEE CLOSURE
(VSZC)**

NON-VISIBLE / SUB-FLASHINGS
ARE NOT PROVIDED IN SPECIFIC
COLORS UNLESS SPECIFIED

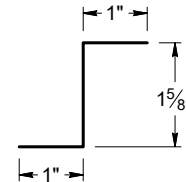

SCALE 1:3 S.O. 3.625" WEIGHT: 3 LBS.

**OFFSET CLEAT
(VSOC)**

NON-VISIBLE / SUB-FLASHINGS
ARE NOT PROVIDED IN SPECIFIC
COLORS UNLESS SPECIFIED

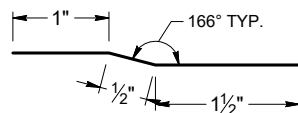

SCALE 1:2 S.O. 3" WEIGHT: 2.5 LBS.



Order Form

Inside Sale: _____

- New Order Add-on Order Quote

PO #: _____ Date: _____

Sold To: _____

Job Name: _____

Ship To: _____

Order Contact: _____

Phone #: _____

Fax #: _____

- Will Call Delivery

Day: _____ Delivery Date: _____

- Agricultural Residential Commercial Route: _____

Standard Panels are in Bold font.

Panels with * need Pattern Choice:
 Ribs Striations Flat (Flat not available on StreamLine)
 Notched? Y/N Clip Relief? Y/N Sealant? Y/N

- 12-3/8" Slim-Lock***
- 16-1/4" Slim-Lock***
- 12" MS-200*
- 14-5/8" MS-200***
- 16" MS-200*
- 18" MS-200***
- 12-3/4" MS-150***
- 16-5/8" MS-150***
- 20" MS-150***
- 13-3/4" MS-100***
- 17-5/8" MS-100***

Color: _____
 Pitch: _____
 Gauge: _____
 Dmatch: _____
 Pallet: 10' 20' 30'

- PBR**
- Marion "R" Panel**
- Max Corr**
- 2-1/2" Corrugated**
- Classic 7/8" Corrugated**
- GR-7**
- HR-34**
- T-3**
- Tuff-Rib**

- 12" Easy-Lock*** ShadowLine** (circle): 1", or 1-1/2"
- 16" Easy-Lock*** 1/2" to 3" Reveal: _____
- 16" StreamLine*** **1"x12-5/8" SmoothWall****
- 12" CL-175*** **1"x12-5/8" Lifetime Soffit****

Panels with ** need Pattern Choice:
 Striations Flat 1 V-Groove 2 V-Grooves
 Perforated? (Available on Lifetime Soffit Only)

- 12" Versa-Span*
- 14-5/8" Versa-Span***
- 16" Versa-Span*
- 18" Versa-Span***
- 15-1/2" T-Panel***

Panel & Flashing Items

*All Kynar Slim-Lock, Easy-Lock, Lifetime Soffit, SmoothWall, ShadowLine, T-Panel, Versa-Span, CL-175, MS-100, MS-150, & MS-200 flashings are 10' *All ArmorTech StreamLine, T-3, Tuff Rib, GR7, PBR, HR-32, Marion "R", & Corrugated flashings are 12'6"

Quantity	Length	Item Description	Part #	Quantity	Length	Item Description	Part #

Forgetting Anything? Underlayment? Screws? Clips? Caulking? Closures?

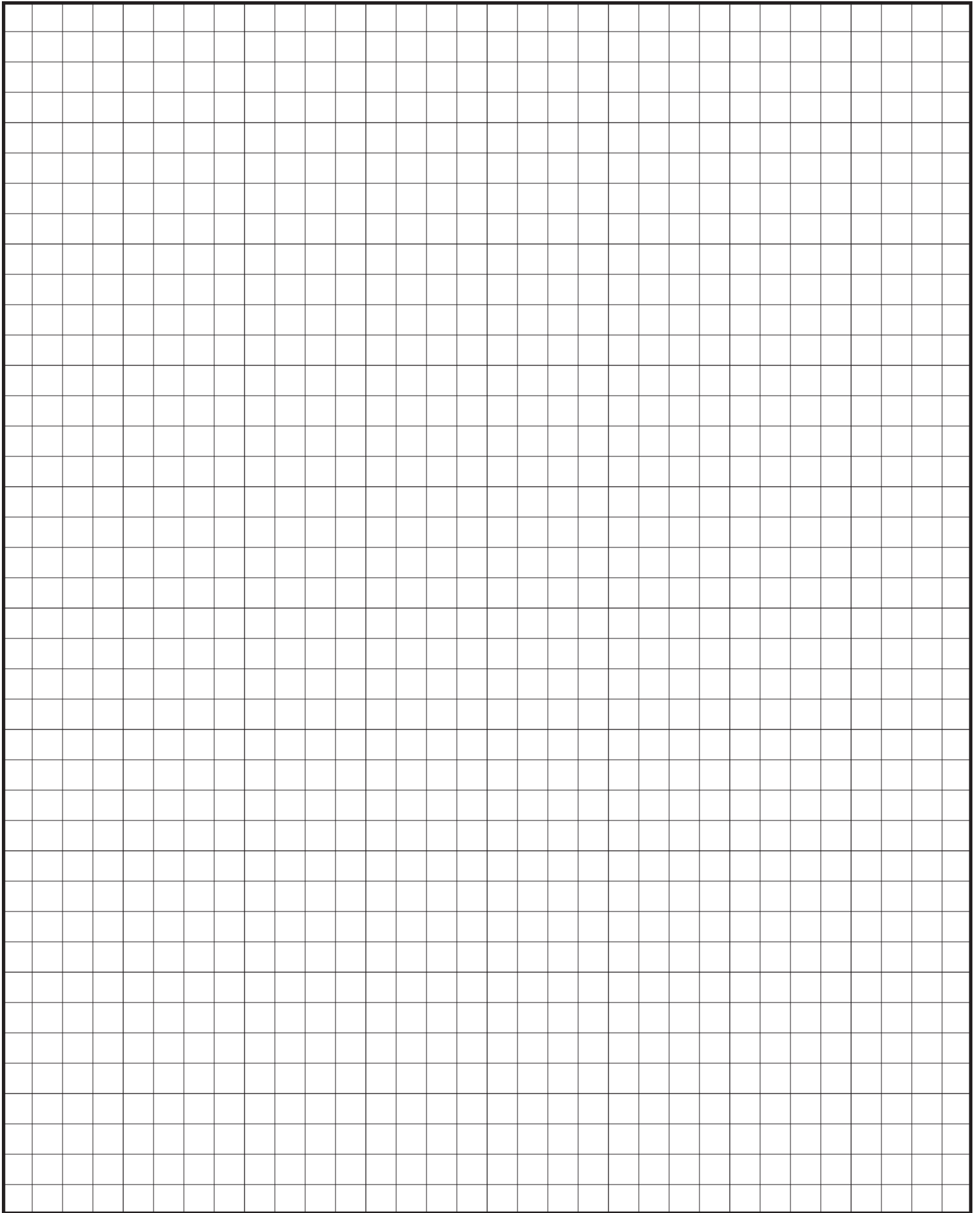



Custom Trim Order

Customer Name: _____ Job Name: _____

Gauge: _____ Color: _____ Status: Original New

Specify: Angles Color Side Dimensions Stretchout

SO _____

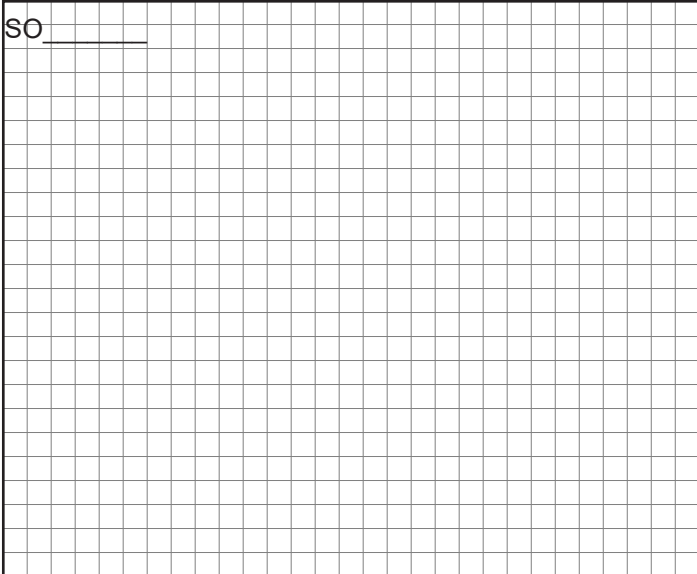

Dwg #: _____ Pitch: _____ # of Pieces: _____

Description: _____

Hems: Open Closed Slightly Open

SO _____

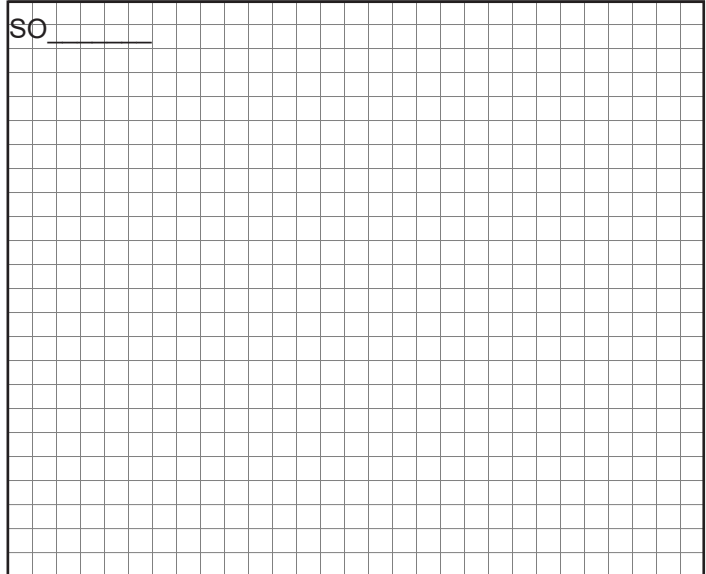

Dwg #: _____ Pitch: _____ # of Pieces: _____

Description: _____

Hems: Open Closed Slightly Open

SO _____

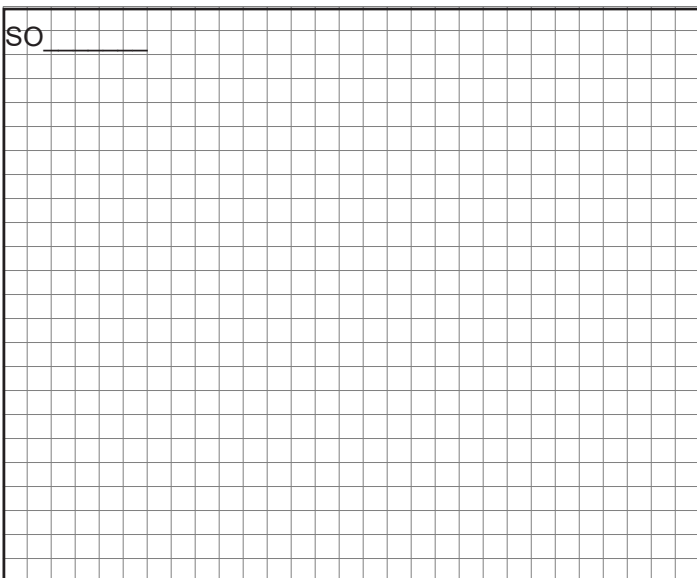

Dwg #: _____ Pitch: _____ # of Pieces: _____

Description: _____

Hems: Open Closed Slightly Open

SO _____

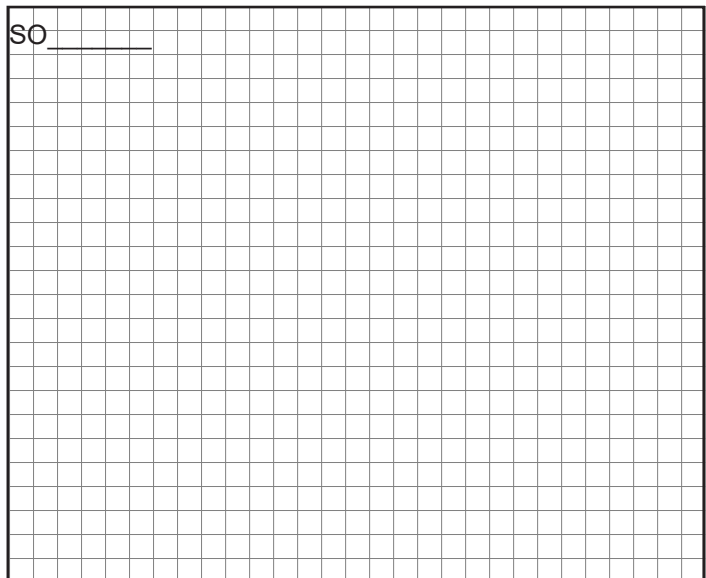

Dwg #: _____ Pitch: _____ # of Pieces: _____

Description: _____

Hems: Open Closed Slightly Open

Please provide a drawing for each flashing with precise measurements and angles
Fax to: 503-581-6877

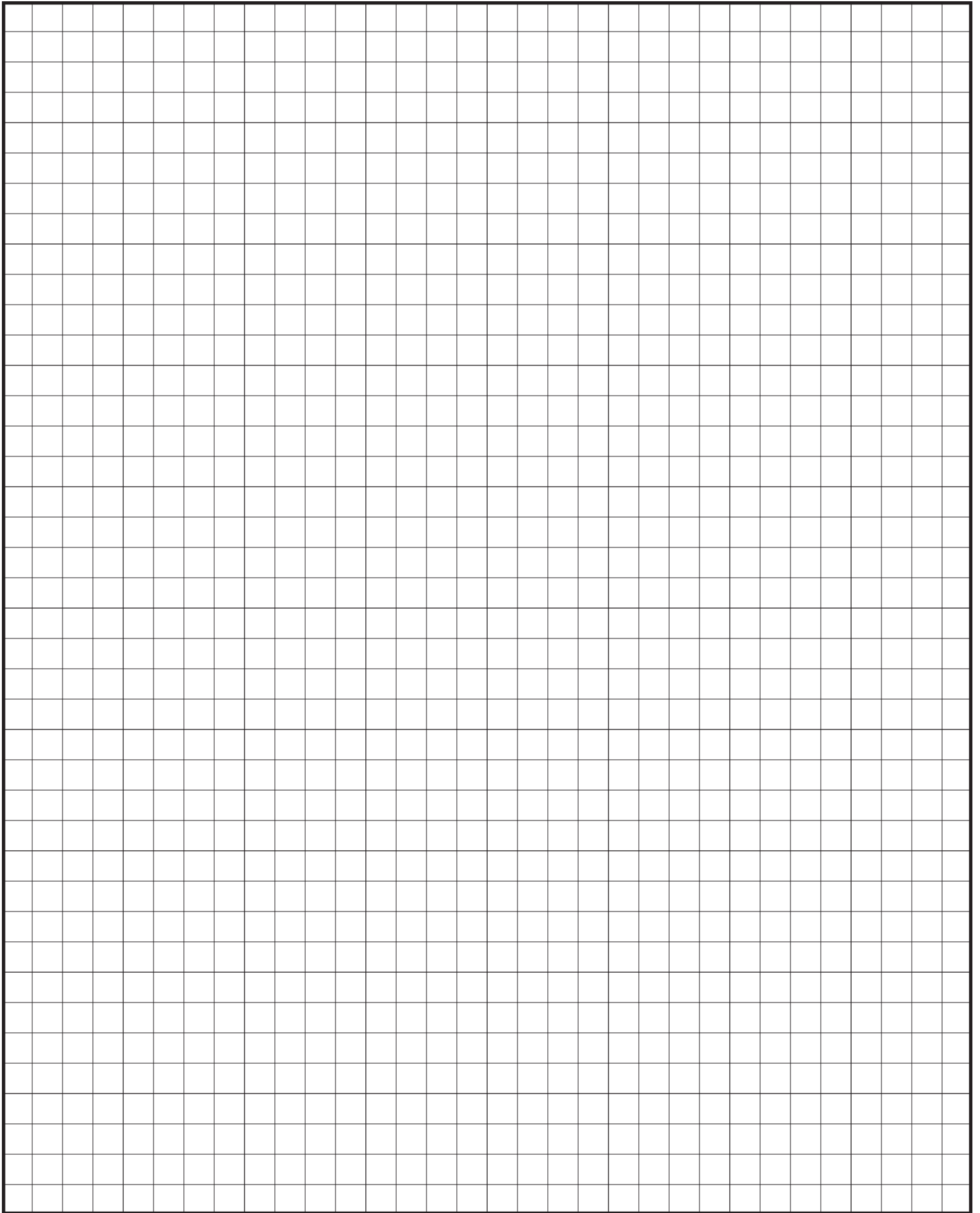



Custom Trim Order

Customer Name: _____ Job Name: _____

Gauge: _____ Color: _____ Status: Original New

Specify: Angles Color Side Dimensions Stretchout

SO _____

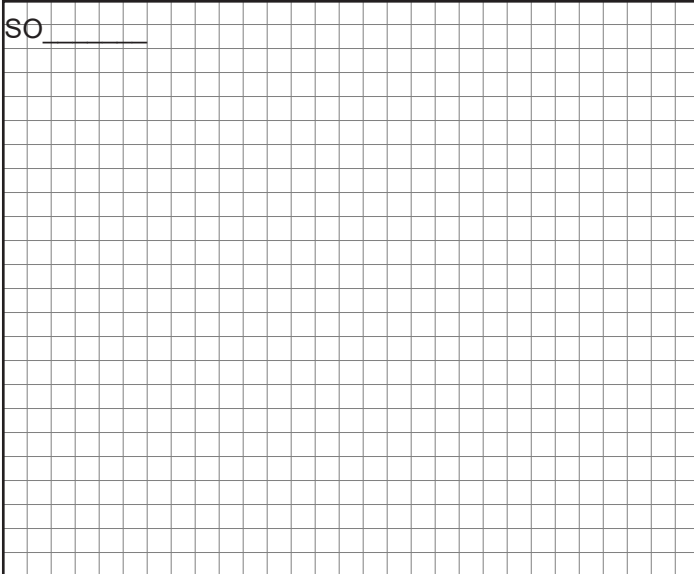

Dwg #: _____ Pitch: _____ # of Pieces: _____

Description: _____

Hems: Open Closed Slightly Open

SO _____

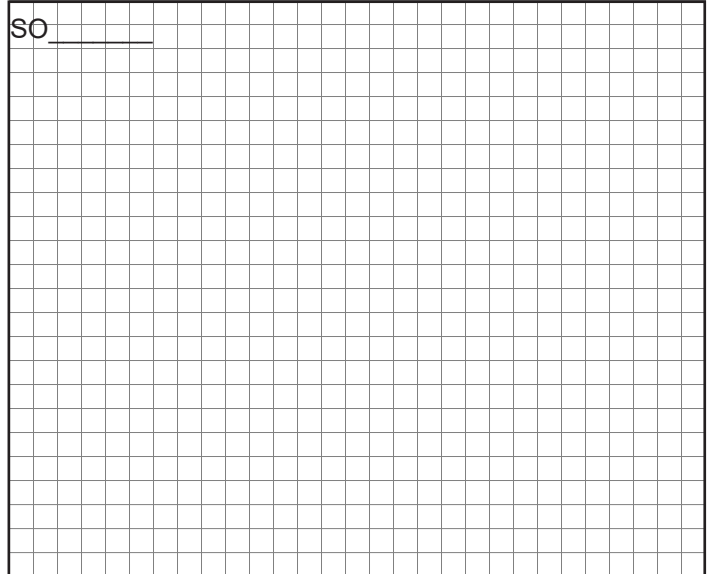

Dwg #: _____ Pitch: _____ # of Pieces: _____

Description: _____

Hems: Open Closed Slightly Open

SO _____

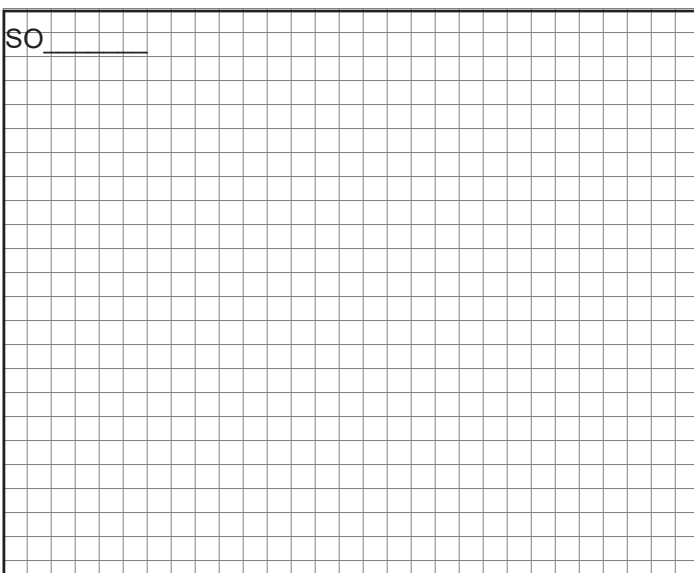

Dwg #: _____ Pitch: _____ # of Pieces: _____

Description: _____

Hems: Open Closed Slightly Open

SO _____

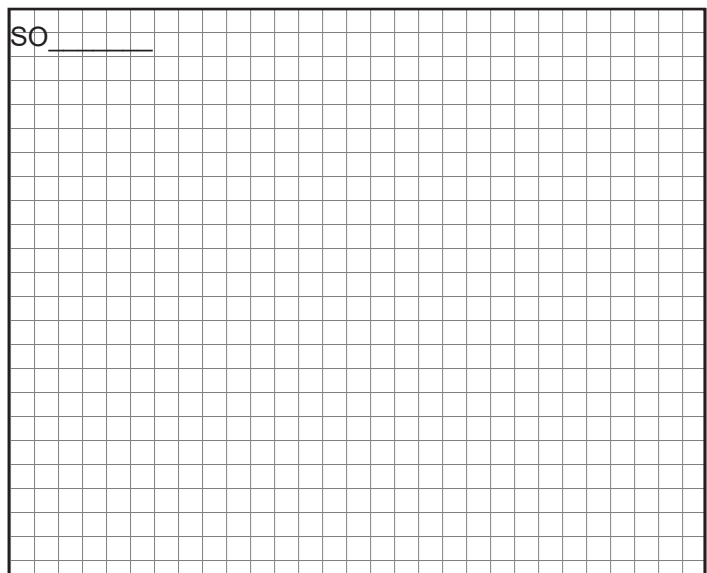

Dwg #: _____ Pitch: _____ # of Pieces: _____

Description: _____

Hems: Open Closed Slightly Open

Please provide a drawing for each flashing with precise measurements and angles
Fax to: 503-581-6877

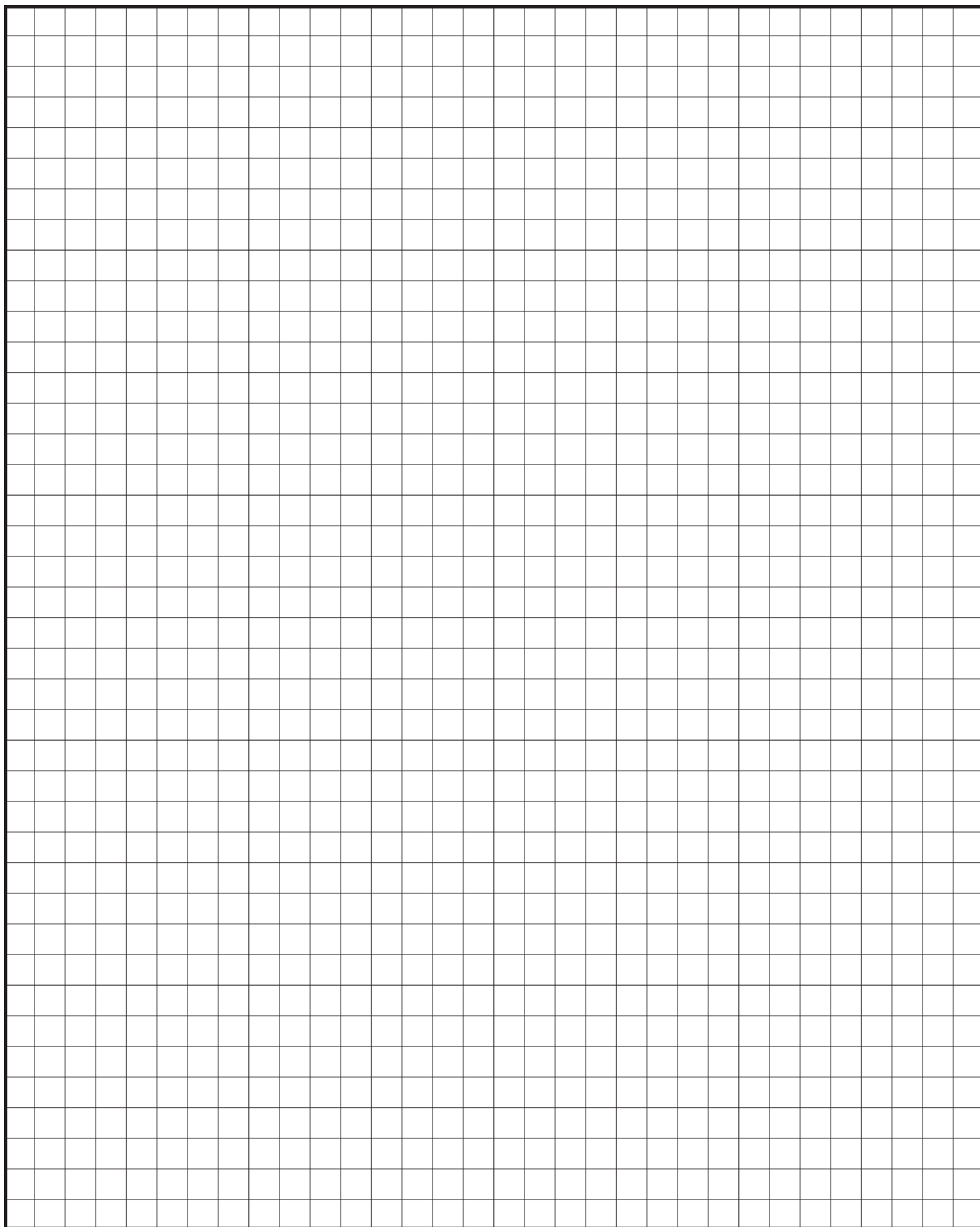



TAYLOR

METAL PRODUCTS

QUALITY PRODUCTS
EXCEPTIONAL SERVICE

SALEM BRANCH

4566 Ridge Dr. NE
Salem, OR 97301

Office: 503-581-8338
Toll Free: 1-800-574-1388
Fax: 503-581-6877

SACRAMENTO BRANCH

5711 Perrin Ave
McClellan, CA 95652

Office: 916-318-8844
Toll Free: 1-800-574-1388
Fax: 916-993-4123

AUBURN BRANCH

2601 C St. SW
Auburn, WA 98001

Office: 206-900-9923
Toll Free: 1-800-574-1388
Fax: 253-804-3545

RIVERSIDE BRANCH

4880 Felspar St.
Riverside, CA 92509

Office: 323-407-7457
Toll Free: 1-877-504-1594

SPOKANE BRANCH

1010 N Nelson St
Spokane, WA 99202

Office: 509-535-8667
Toll Free: 800-238-4057
Fax: 509-535-8682