



Clip-Lock™ Installation Guide

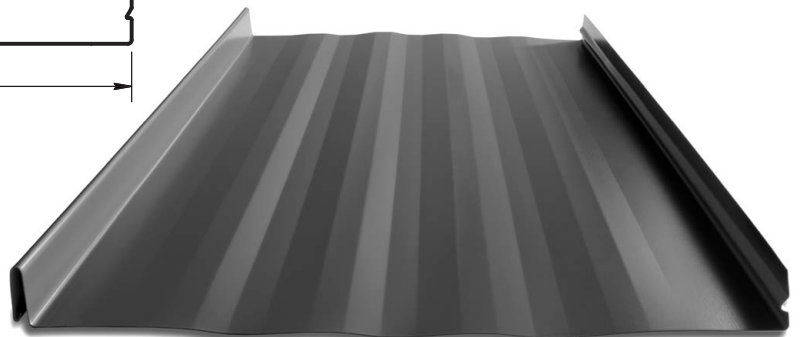
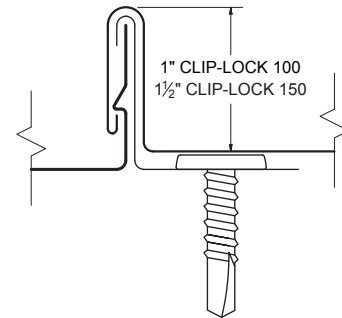
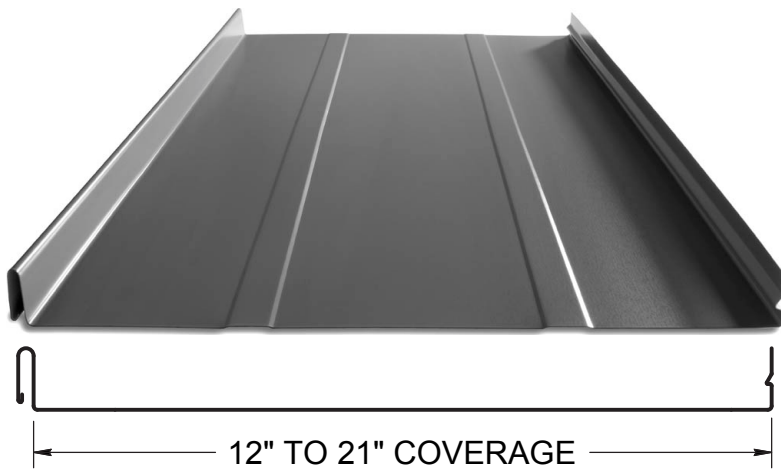
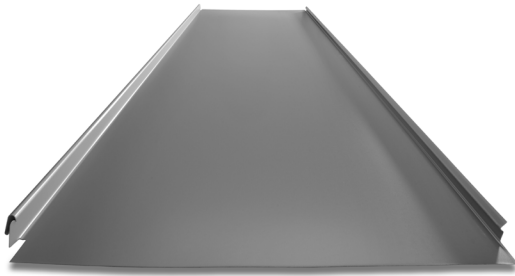
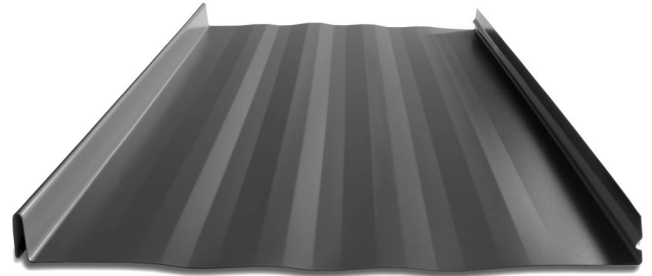

Table of Contents

Panel Specifications	4-5
Taylor Delivery Fleet	6
Delivery, Will Call & Loading	7
Notes To Designer/Installer	8-9
Handling / Storage & Safety	10
Standard Eave Detail	11
Hook Eave	12
Hook Eave with Gutter Detail.....	13
Standard Ridge Detail.....	14
Vented Ridge Detail.....	15
End Dam	16
Valley	17
Valley – Low Slope	18
Standard Gable Detail	19
Alternate Gable Detail.....	20
Sidewall Detail.....	21
Peak Flashing	22
Pitch Change	23
End Wall	24
Vented End Wall	25
Curb Back Pan / Cricket	26-28
Curb Sidewall	29
Curb End Wall	30
Curb/Pan Cricket	31
Eave to Gable Transition	32-34
Pipe Penetration – on Plate	35
Pipe Penetration – on Rib	36-37
Pipe Penetration – on Pan	38
Flashing Selection	39-42



FLAT PAN



STRIATIONS

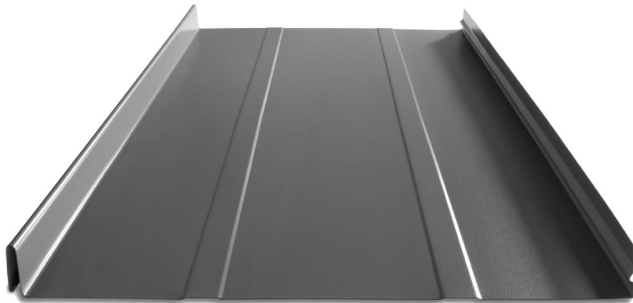

ACCENT RIBS
2 Ribs available

SEAM DETAIL

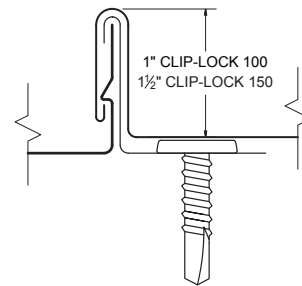

KEY FEATURES

- Standard widths for Clip-Lock 100 are 13" or 17"
Standard width for Clip-Lock 150 is 15.5"
(Please inquire for other coverage options)
- 24 and 22 gauge steel and .032" and .040" Aluminum
- Factory notched & tabbed panels available
- Clip system: allows for expansion/contraction of panels in longer lengths
- Clip-Lock 100 – 1" rib height
- Clip-Lock 150 – 1-1/2" rib height
- Concealed fastener system
- 3:12 minimum pitch recommended
(For lower pitches, please inquire)
- Standard panel lengths 3' to 50'
(For longer panels, please inquire)
- Panel options: Striations, Accent Ribs, and Flat Pan
- Manufactured in Sacramento and Riverside, CA

TESTING

-  Code compliance UL Evaluation Report
UL ER #25913-01
- UL Construction No. 589
- UL 580 Class 90 - Wind Uplift
- UL 790 Class A (ASTM E108) - Fire rated
- UL 2218 Class 4 - Impact (hail) rated
- ASTM A653/A924 - G90 Galvanized
- ASTM A792 - Zincalume/Galvalume AZ-50/55
- ASTM B209 - Aluminum Substrate

The Clip-Lock™ Standing Seam delivers a panel with strong clean continuous grace, together with unequaled quality. This provides you a weather tight roof to last a lifetime. Clip system allows for extremely long panels, without the need for laps.



MATERIAL SPECIFICATIONS

- 24 Tru-Gauge™ Kynar 500® Painted Steel
- ▲ 22 Tru-Gauge™ Kynar 500® Painted Steel
- ◆ .032" Kynar 500® Painted Aluminum
- 24 Tru-Gauge™ G-90 Galvanized or AZ-50
- 24 and 22 Tru-Gauge™ bare Zincolume® Plus AZ-55
(No finish warranty – 25 yr. perforation warranty)
- G-90 Galvanized or AZ-50
- .032" & .040" Kynar 500® Painted Aluminum
(please inquire)
- 24 Tru-Gauge™ Bonderized
- 22 gauge Rusteel Plus™ (A606)
- 16 OZ & 20 OZ Real Copper
- Kynar 500® and substrate testing data available
(See website)

FINISHES

- 21 Standard Colors, 5 Metallic Colors and 4 Specialized Colors
- Kynar 500® Paint System - the ultimate in exterior durability and color retention
- "Cool" color pigments are specially designed to reflect infrared light, reducing heat gain to dwelling, and conform with ENERGY STAR® criteria
- Superior quality, two coat, 70% resin finish, applied at a 1 mil. thickness
- 40 year residential paint warranty
- 20 and 30 year commercial paint warranty: Contact TMP for warranty specifications
- "Oil Canning" is an inherent characteristic of roof and wall products, and not a defect, which is not a cause for panel rejection

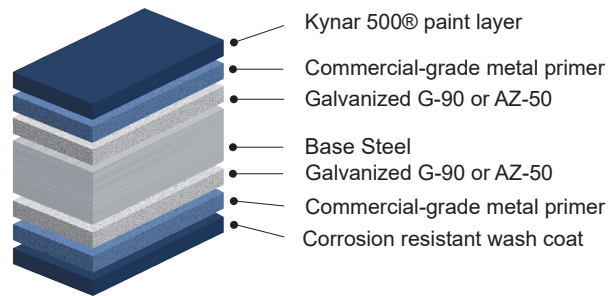

STANDARD COOL KYNAR 500® COLORS

▲ 22 Tru-Gauge™
◆ .032 Aluminum

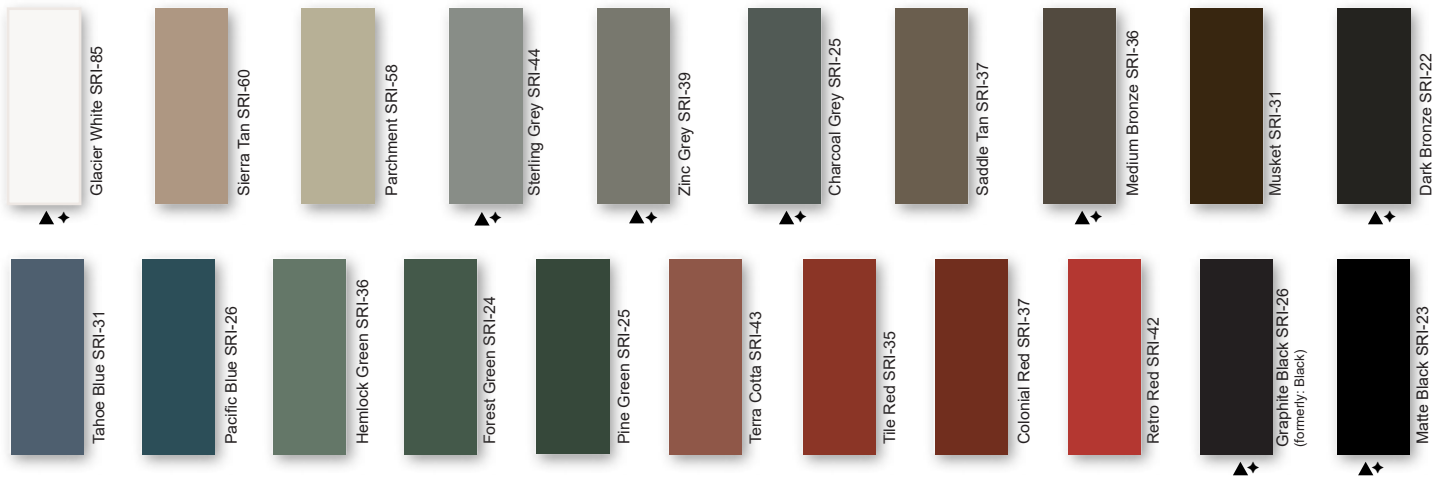

PREMIUM METALLIC COOL KYNAR® COLORS

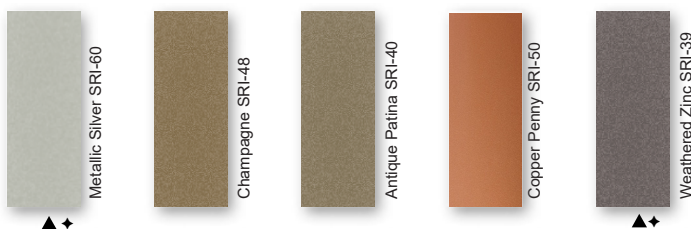

SPECIALIZED MATERIAL

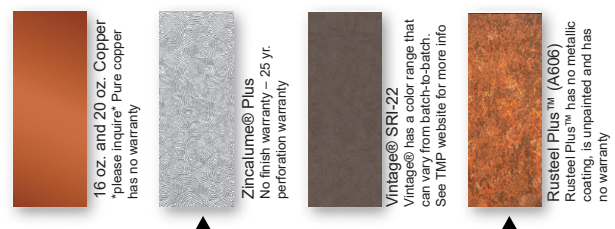

These printed chips provide a close representation of the colors.

Metal samples are available upon request. Coatings are low gloss 10-15% sheen.
SRI = Solar Reflective Index. SRI values listed above are in accordance with ASTM E 1980 and are based on actual testing.***Oil canning is not a cause for material rejection***



Taylor Delivery Fleet



Delivery Fleet

Taylor Metal Products prides itself with quick lead times delivered with our fleet of semi trucks. Our fleet of trucks are owned and operated by TMP. All of our drivers are Taylor Metal Products employees, so when your truck rolls in to deliver, you are dealing with Taylor Metal Products.

Expect consistent and exceptional service with short lead times. The inhouse fleet allows for efficient and cost-effective delivery.



Mounted on the rear of our semitrailer, the truck-mounted "piggy-back" forklift will accompany you right to your place of use, opening up unprecedented possibilities in terms of transportation. It can travel sideways, carrying panels up to 40' long, allowing delivery in locations that would typically be considered impossible to reach.

Save time and effort while avoiding potential loading and transport issues; have experienced TMP personnel deliver and unload your order.



Delivery

We will make every attempt to deliver material to the desired location. We may be unable to gain access on tight corners or steep terrain. If the site is deemed inaccessible by our driver, the customer may choose an alternate delivery site within a reasonable proximity. If we are unable to make the alternate delivery, additional charges may be assessed.

The customer is responsible for:

- Determining adequate access for delivery ahead of time.
- Meeting the delivery at the agreed upon time.
- Providing adequate resources (1-4 people as needed) for off loading materials.
- A charge of \$100 per hour may be added for deliveries that go beyond their allotted time
- Check the shipment at the time of delivery.
- Verify material quantities against the shipping/packing list.
- Note any damage or discrepancies upon the paper work at the time of delivery and notify Taylor Metal Products within 48 hours of delivery.

Delivery times are usually scheduled one day in advance. Taylor Metal Products will make every effort to make the delivery at the scheduled time. Please be aware that there may be conditions beyond our control such as traffic, mechanical failures, road closures, etc. which may affect our schedule.

Will Call/Loading

Flatbed trailers and trucks are best suited to transport metal roofing materials. These can be loaded from the side with a forklift and tied down in a safe and secure manner.

We are not able to load materials onto vehicles and/or trailers which are not suitable or may be hazardous to load. Please be aware that if we find a vehicle to be inappropriate, we reserve the right to refuse to load your order.

Unacceptable examples include: boat trailers, vans, buses, motor homes, campers and box trailers. Pickup racks which do not have sufficient supports for the weight or are not long enough to support bundles are also unacceptable.

Taylor Metal Products is **not** responsible to tie down loads nor do we provide any tie down materials. Please bring tie downs to secure your load (string or twine are **not** acceptable for this purpose).

Consider having your order delivered on one of our trucks with a piggy back forklift.



Notes to Designer/Installer

Taylor Metal Products is providing the following details as an aid in design. The details in this guide are not inclusive to all design situations. The designer/installer is responsible for modifications and should take into consideration all aspects of the project including climate conditions, such as, snow and wind, as well as, building code requirements, building design, building usage and maintenance requirements.

Installation should be performed only by qualified installers familiar with metal roofing systems and industry standards. For details not shown in this guide, refer to the Sheet Metal and Air Conditioning Contractors National Association (SMACNA) architectural sheet metal manual for proper design. For manufacturer's weather tightness warranties – all details must be preapproved by Taylor Metal Products technical representative.

The Standard gauge for all products in this guide is 24 gauge and the standard finish is Kynar 500®. We recommend specifying all flashings be the same gauge, color, and finish as the panels to insure long-term durability and color match.

Substrates

Details in the manual are all shown over solid substrate. **Clip-Lock** can be used over spaced purlins. For solid substrate, **Taylor Metal Products** recommends 5/8" plywood or metal decking.

Underlayment

For roofs with pitches below 3:12, High Temp Ice and Water shield underlayment must be installed across the entire surface (projects with manufacturer's weathertightness warranties require the TMP private label product). For pitches steeper than (or equal to) 3:12, High Temp Ice and Water is necessary at all perimeter locations, eave, ridge, valley, hips, sidewall, endwall, prow and penetrations. The remaining of the roof's field areas can then be covered with approved synthetic felt. If local codes or specifications require a Class A fire rated assembly, Polystick XFR or Titanium FR (both products are distributed by TMP) must be installed over the entire roof with combustible decks.

Follow manufactures instructions carefully for all underlayment installation.

Drag Load Requirements

All panels must be pinned at one end to resist the drag load caused by snow loads, live loads, and the weight of the panel. Drag load is a function of roof slope, actual load and length of panels. Contact **Taylor Metal Products** for specific drag load requirements.

Ventilation/Insulation

It is the responsibility of the designer to determine the material types needed to control condensation and to insulate and ventilate the roof system. Applications over rigid insulation may require blocking for solid attachment and framing the perimeter for installation of perimeter flashings.

Oil Canning

Flat metal surfaces will display waviness commonly referred to as “oil canning.” Oil canning is caused by a variety of conditions. Steel mill tolerances, variations in or uneven substrates and roofing underlayments. Oil canning is a characteristic of metal roofing, not a defect and is not a cause for rejection. **Taylor Metal Products** offers **Clip-Lock** with striations or accent ribs to help minimize oil canning.

Thermal Movement

The Panels and the flashings must be allowed to expand and contract, especially with longer length panels. The panel may need to have a slight gap where the panel hooks the offset cleat to allow for thermal movement of the panels.

Snow Design

The following details do not address all conditions for snow environments. Consult with the designers, engineers, and others for acceptable details to accommodate your project and climate conditions. When possible gutters, valleys, pitch changes or other penetrations should be minimized in snow areas.

All roof penetrations should be located as close to the ridge or “pin point” top of roof. Snow country requires special designs for valleys to accommodate accumulation of snow and ice from uphill panels. Roof design should be considered in snow areas. Roof design should help resist the melting and freezing of snow and ice.

A fit for purpose roof design has the greatest impact on maintaining a damage free roof system in snow areas. Please contact a Taylor Metal Products representative for assistance in detail designs and appropriate panel selection for specific climate and building conditions.

Handling / Storage & Safety

Handle materials with care when off-loading or moving materials to avoid damage to panels or flashings. Long panels may require two or more pick-up points, properly spaced to avoid damaging panels. Plan ahead; contact Taylor Metal Products for recommendations on handling/hoisting long panels.

Store the panels, flashings and accessories in a dry, well ventilated area, off the ground. If covering, allow ventilation around panels. Elevate one end of bundle to allow drainage of wet materials.

Wear clean, soft-soled shoes when walking on roofing panels to avoid damage to the painted finish.

Take care that sand, gravel, dirt, etc. sticking to your shoes is not carried onto the roof, scratching or otherwise damaging the finish on the roofing material. Walking on asphalt impregnated felt paper, especially on a hot day, can cause the asphalt to stick to your shoes and be tracked on to the roofing material.

Take care when painting to avoid getting over spray on the roofing material. Remember that wind can carry paint particles some distance. Over spray can cause the finish of the roofing material to look dull and may void your warranty.

Secure materials, especially when leaving the site, on the ground or roof to prevent winds from moving the materials. Wind-blown materials may cause damage to the material, property or persons.

Always use proper safety equipment and attire to minimize risk of cuts or other injuries.

Do not walk on panels that have not been completely installed.

Do not walk on major ribs of panels.

Metal roofs that are wet or dusty can be extremely slippery. Wear soft soled shoes and a safety harness to minimize risk of falling.

Avoid installing metal panels in windy conditions.

Safety considerations are the responsibility of the installer and his crew. Be sure to and **use common sense** generally accepted safety practices when installing roofing materials.

STANDARD EAVE DETAIL

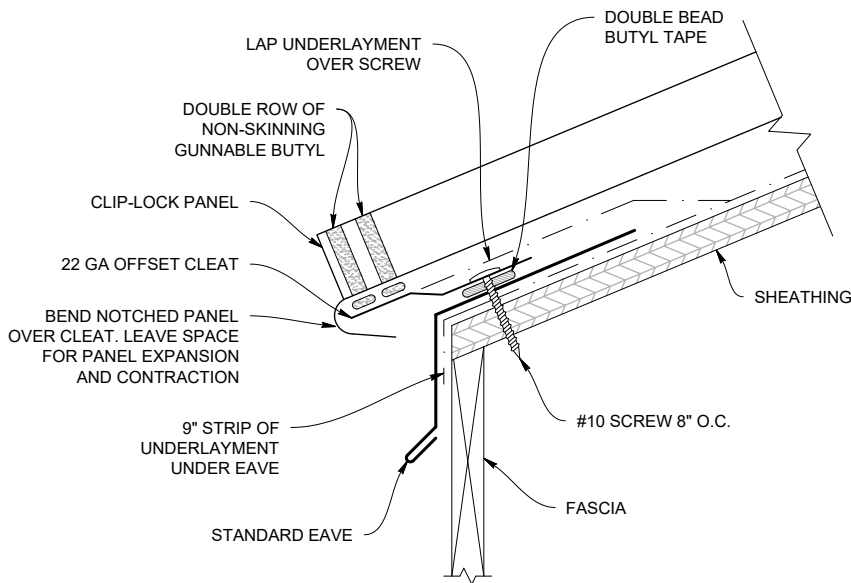

STANDARD EAVE (CLES)

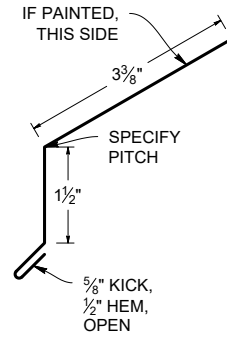

OFFSET CLEAT (CLOC)

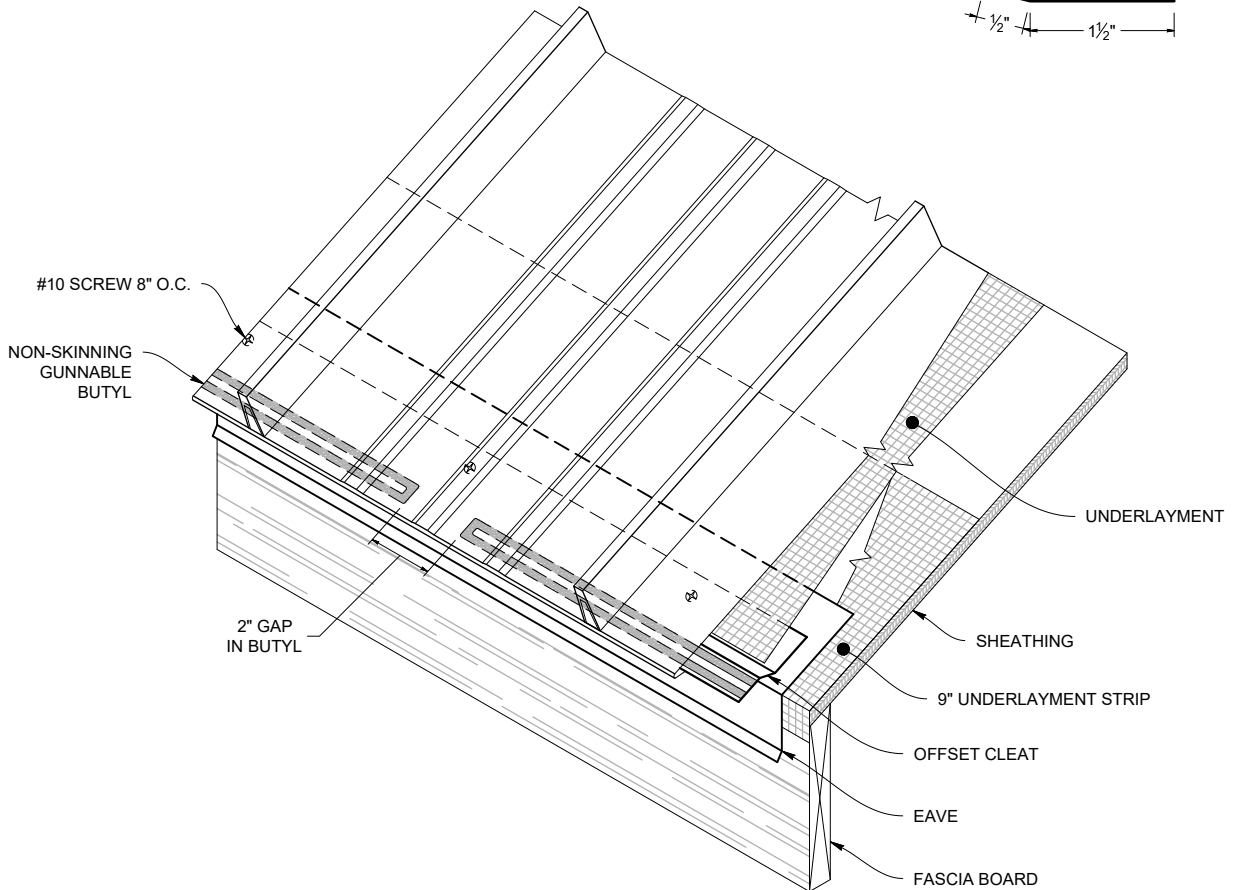
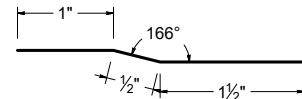

Note: All screws must be fastened into solid substrate.
Flashing must be lapped 4" with 3 rows of gunnable butyl.

Hook Eave

HOOK EAVE DETAIL

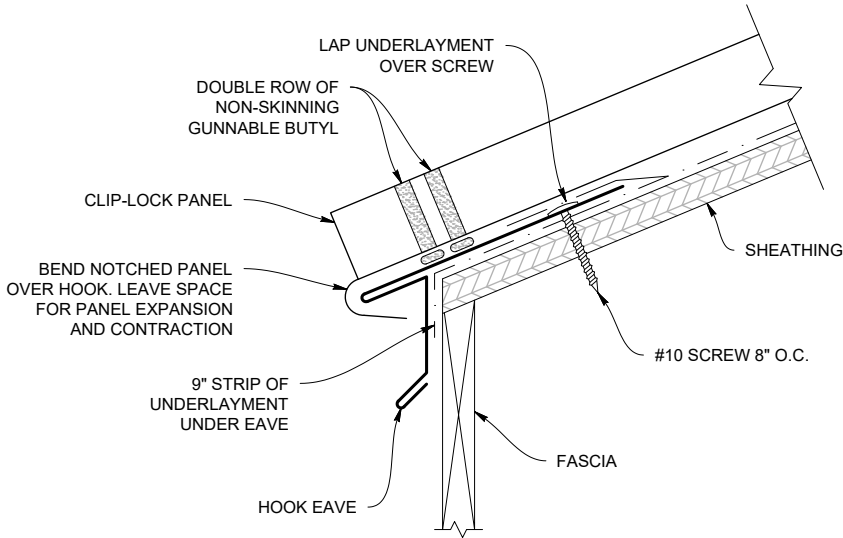

HOOK EAVE (CLEH)

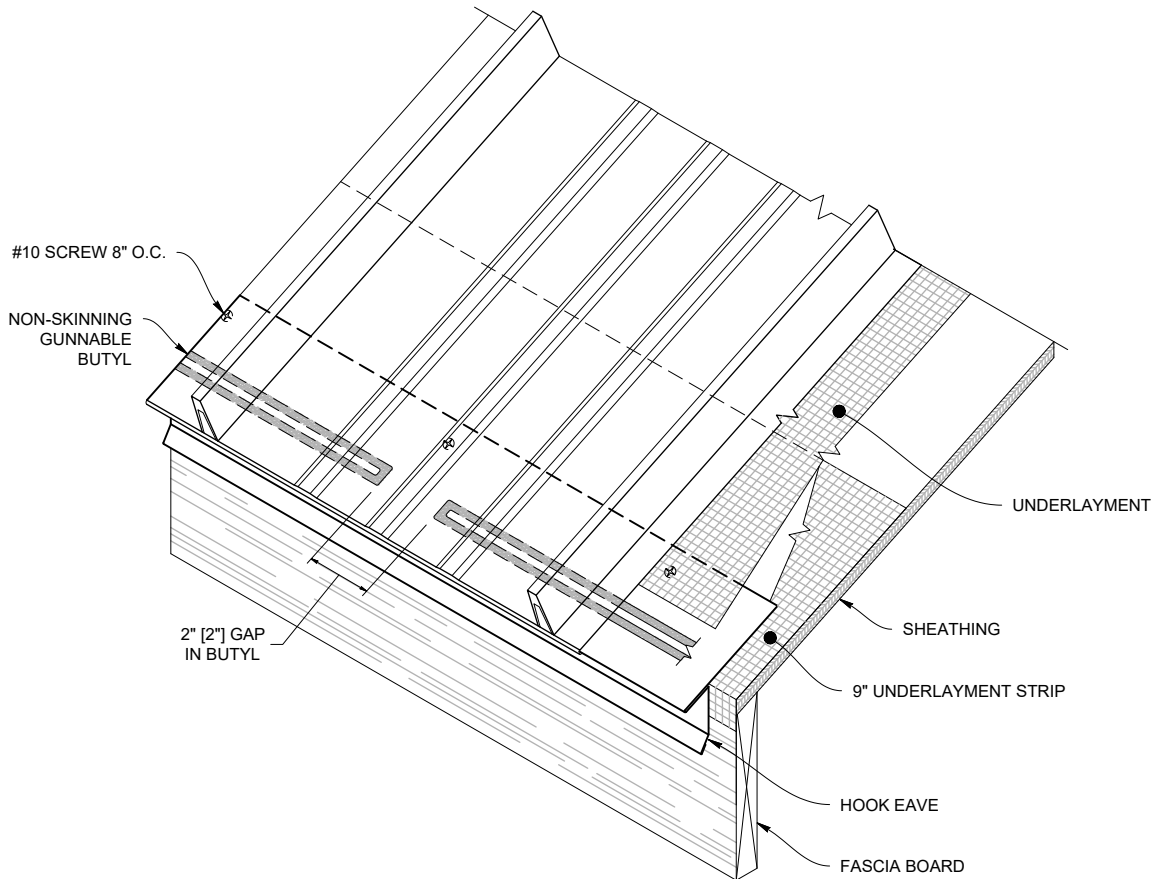
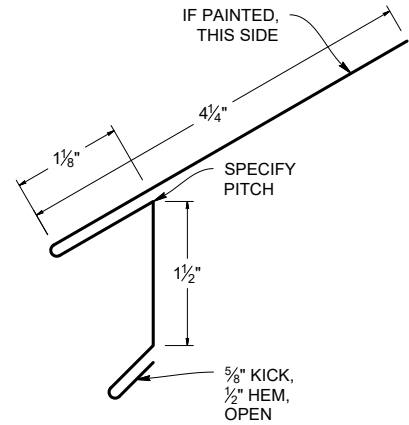

Note: All screws must be fastened into solid substrate.
Flashing must be lapped 4" with 3 rows of gunnable butyl.

HOOK EAVE WITH GUTTER DETAIL

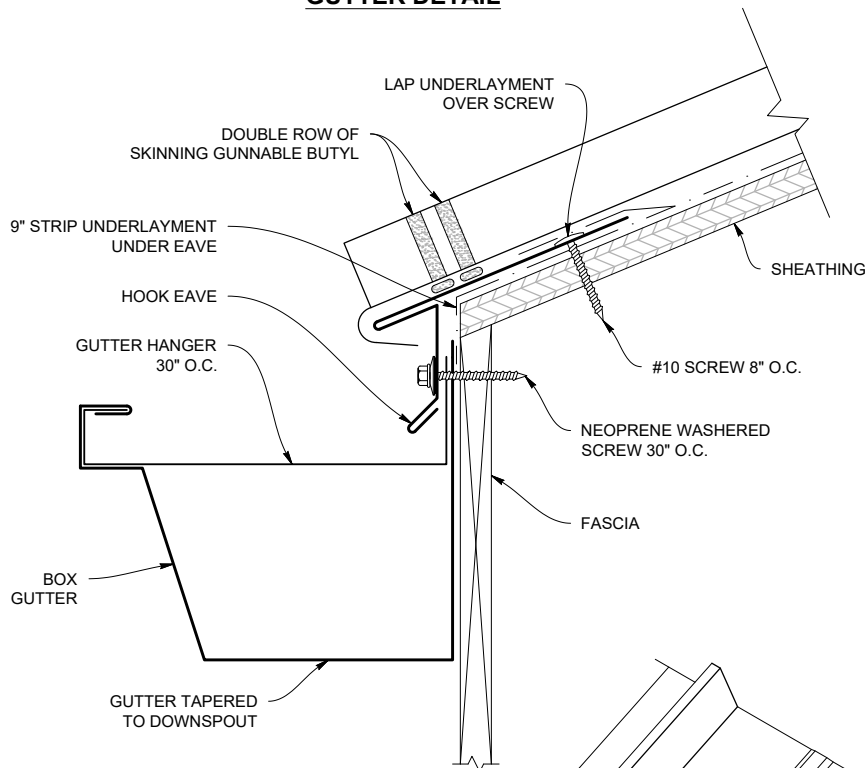

BOX GUTTER (CLBG)

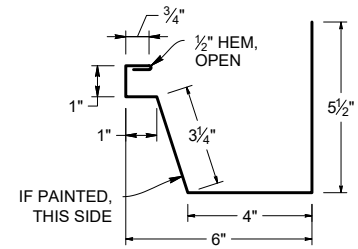

HOOK EAVE (CLEH)

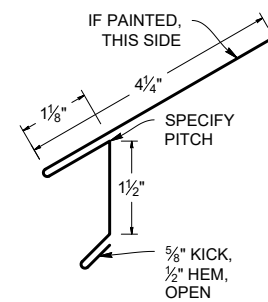

BOX GUTTER HANGER (CLH6)

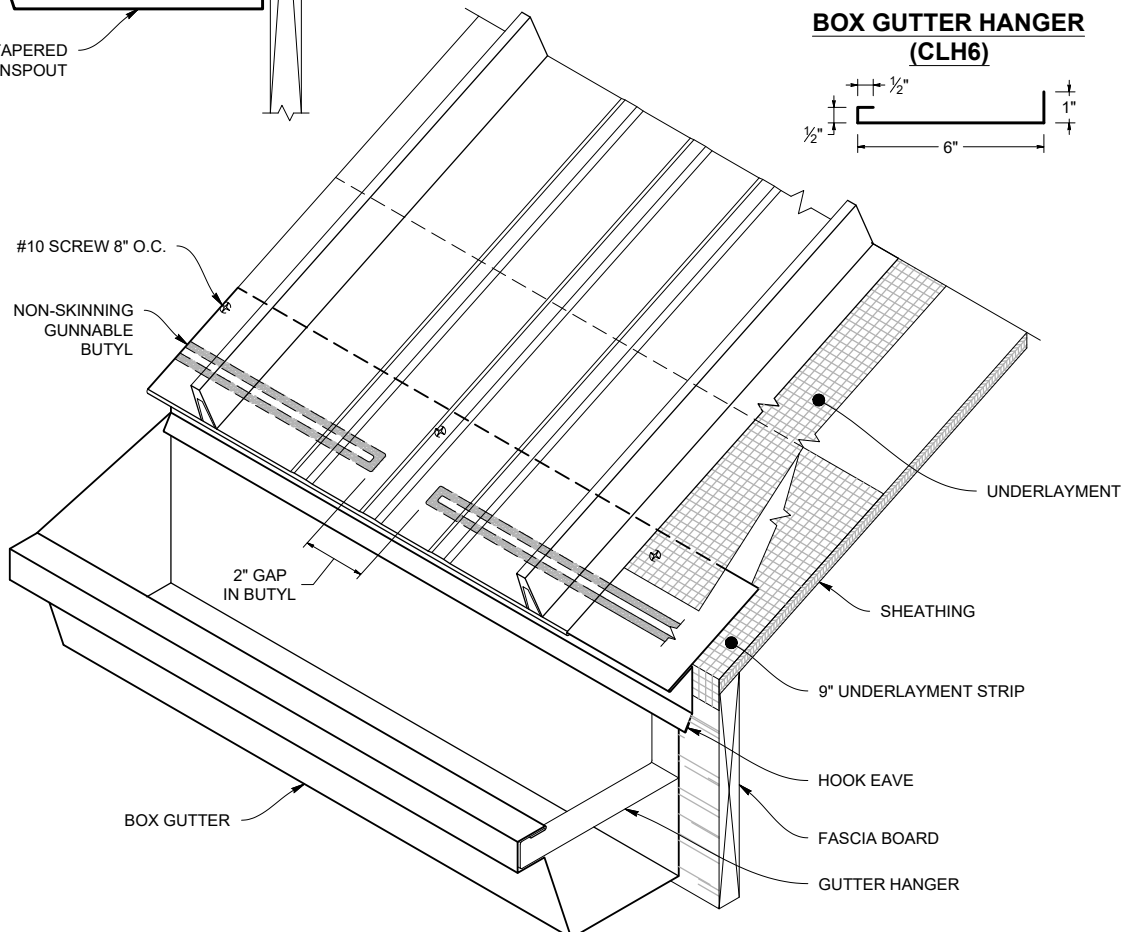
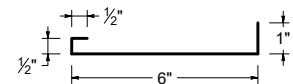

Note: All screws must be fastened into solid substrate.
Flashing must be lapped 4" with 3 rows of gunnable butyl.

Standard Ridge

STANDARD RIDGE DETAIL

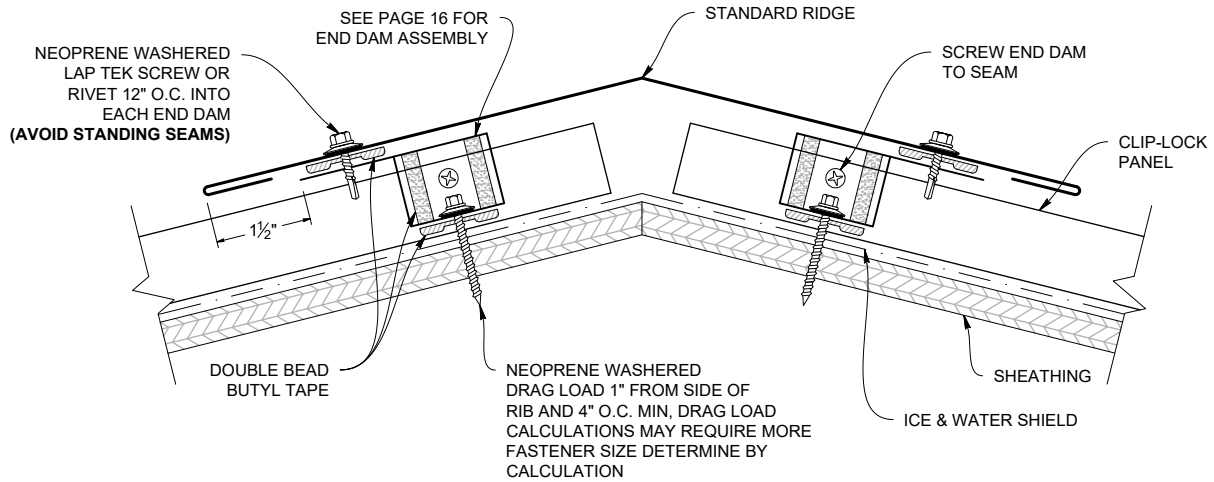

STANDARD RIDGE (CLRS)

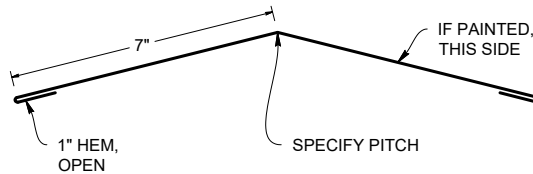

STANDARD RIDGE LAP

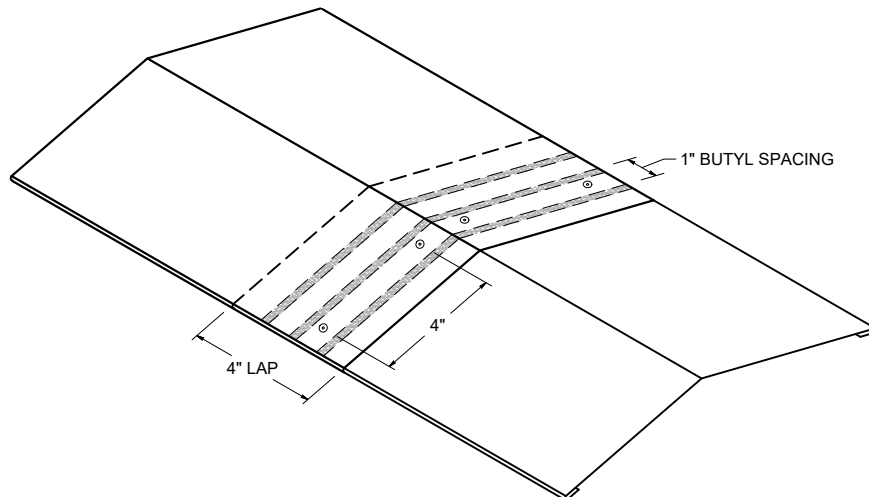

Note: All screws must be fastened into solid substrate.
Flashing must be lapped 4" with 3 rows of gunnable butyl.

VENTED RIDGE DETAIL

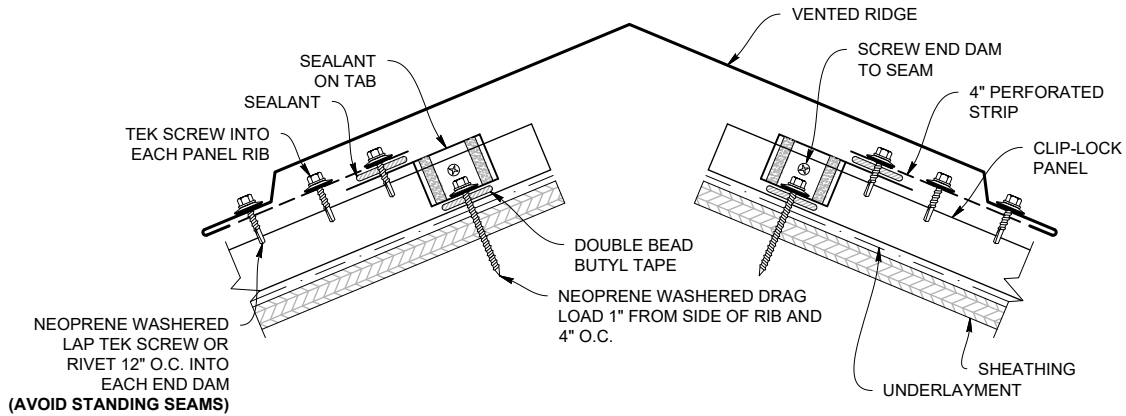

RIDGE FULL VENTED (CLRFV)

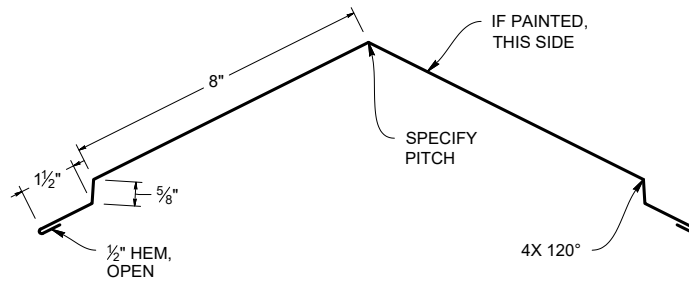

VENTED RIDGE LAP

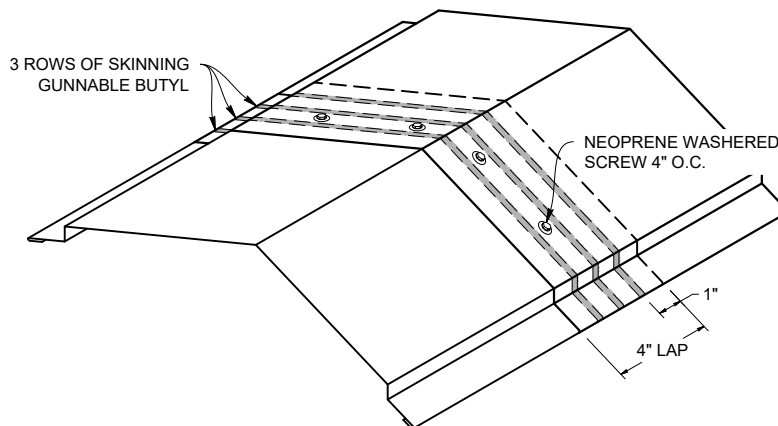

Note: All screws must be fastened into solid substrate.
Flashing must be lapped 4" with 3 rows of gunnable butyl.

END DAM ATTACHMENT APPLICATION

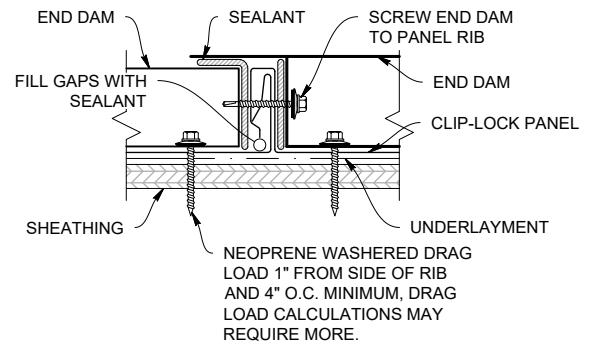
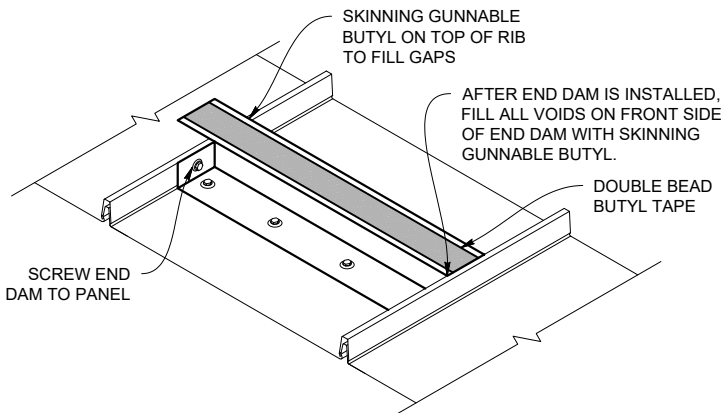
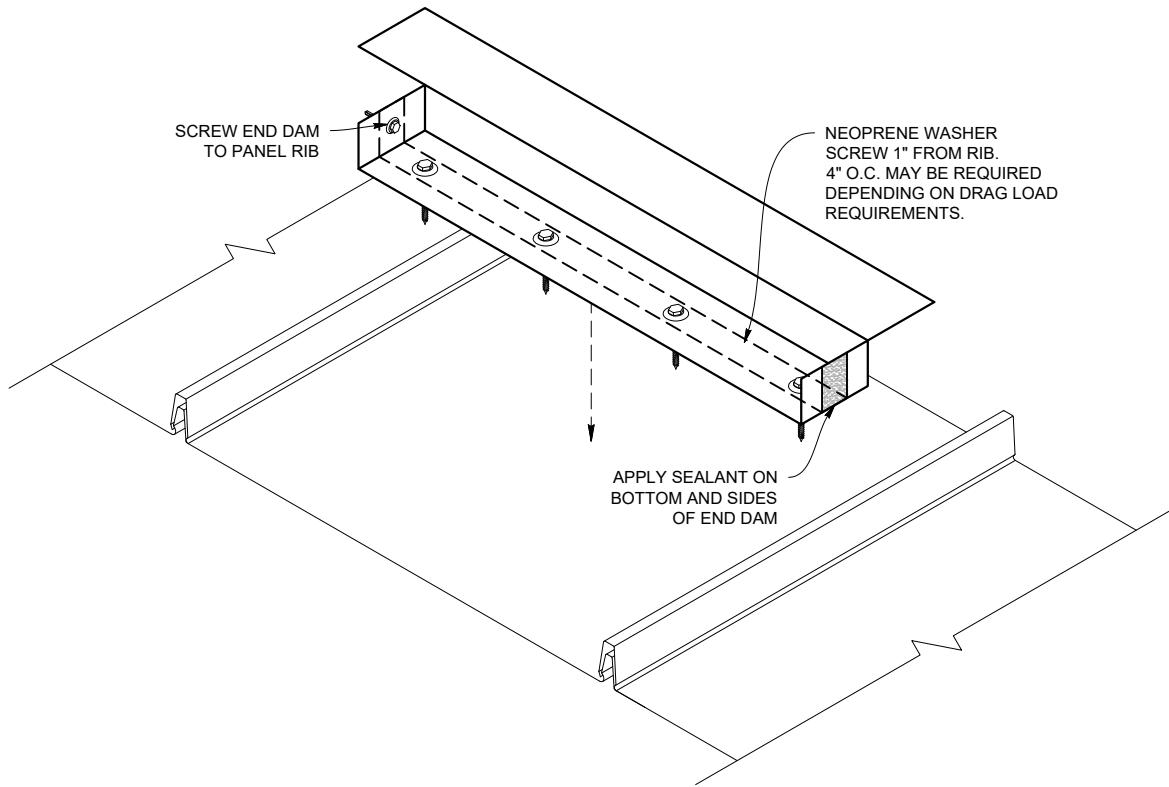

Note: All screws must be fastened into solid substrate.
Flashing must be lapped 4" with 3 rows of gunnable butyl.

VALLEY 24" FLASHING (CLVF)

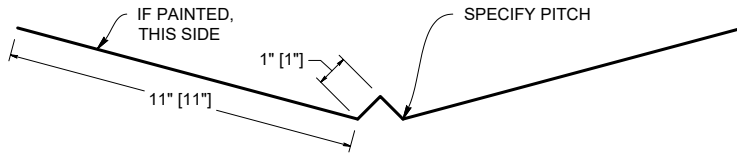

OFFSET CLEAT (CLOC)

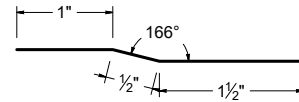

VALLEY 24" DETAIL (3:12 Or Greater Pitch)

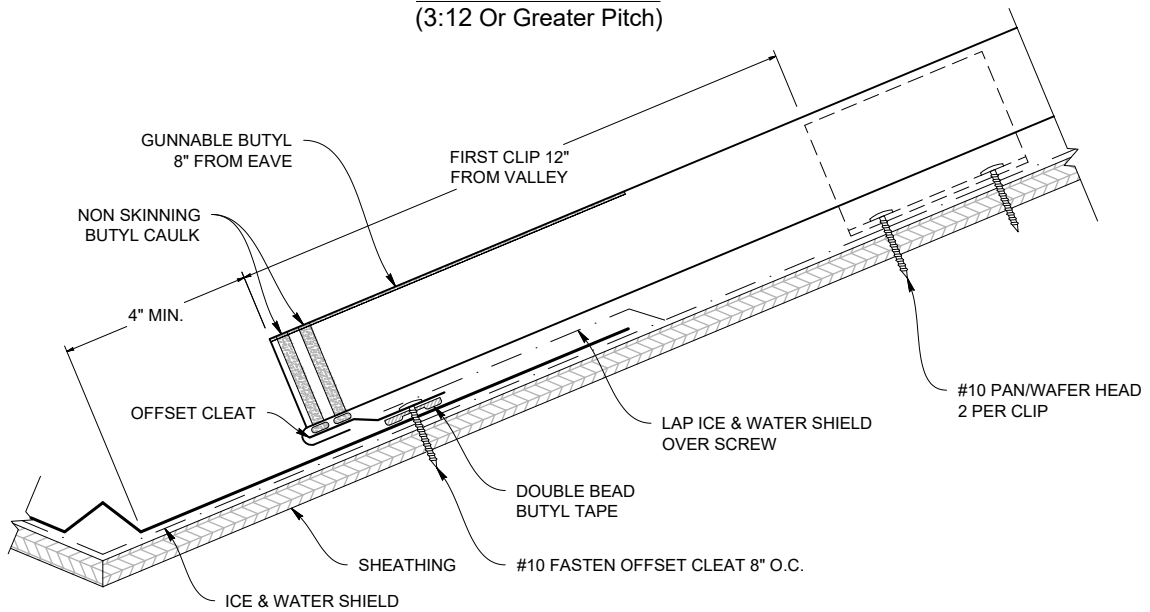

VALLEY LAP (3:12 Or Greater Pitch)

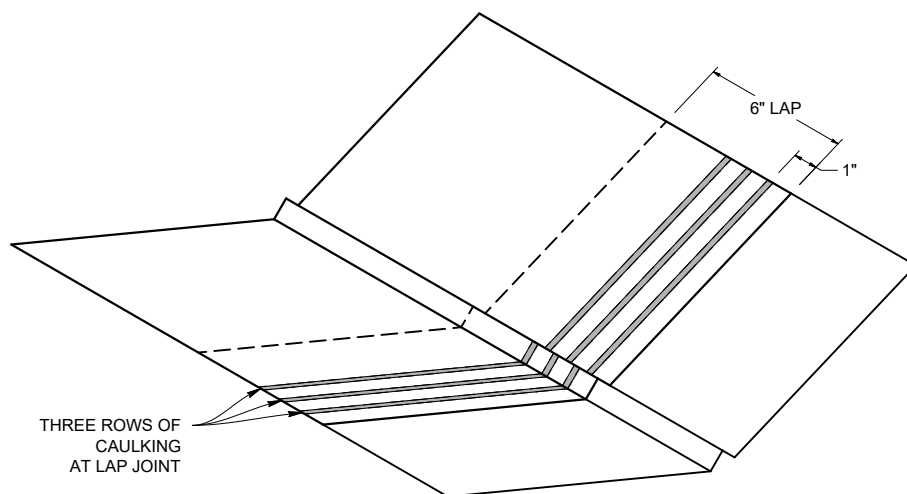

Note: All screws must be fastened into solid substrate.
Flashing must be lapped 4" with 3 rows of gunnable butyl.

Valley Flashing - Low Slope

Slope Less than 3:12



LOW SLOPE VALLEY DETAIL

(Less Than 3:12 Slope Pitch - Not Recommended)

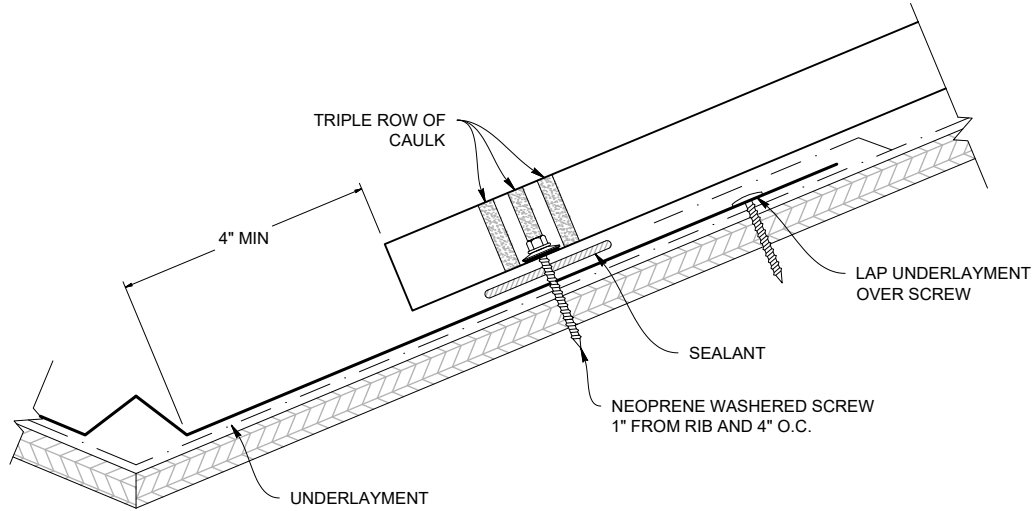

VALLEY FLASHING (CLVF)

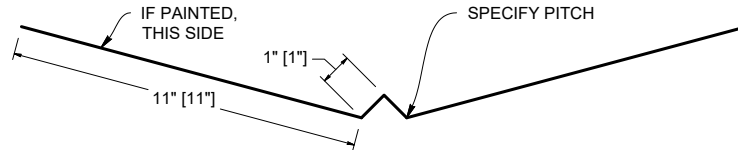

LOW SLOPE VALLEY LAP

(Less Than 3:12 Slope Pitch - Not Recommended)

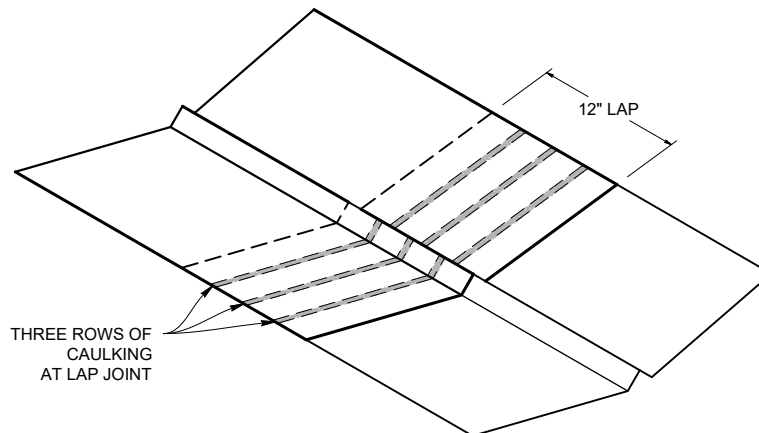

Note: All screws must be fastened into solid substrate.
Flashing must be lapped 4" with 3 rows of gunnable butyl.

STANDARD GABLE DETAIL

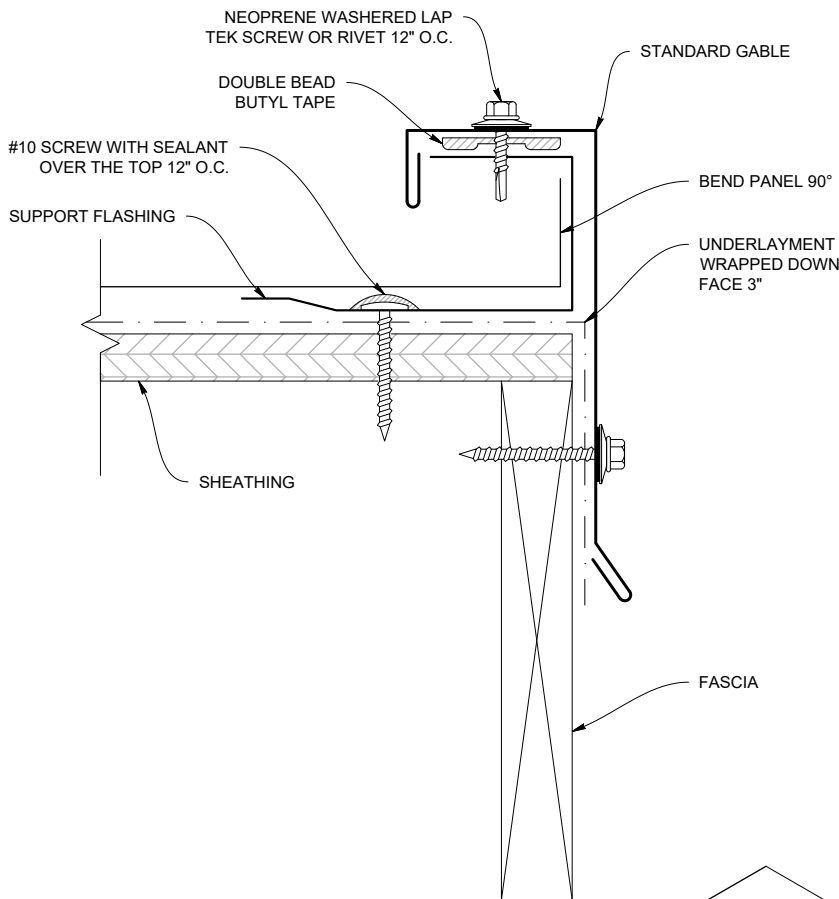

STANDARD GABLE (CLGS)

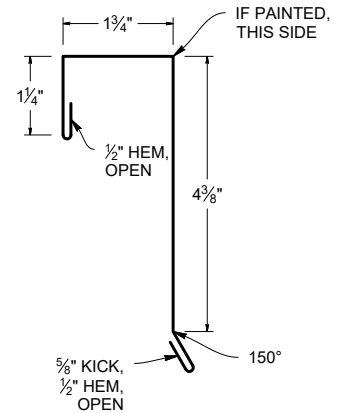

SUPPORT FLASHING (CLSF)

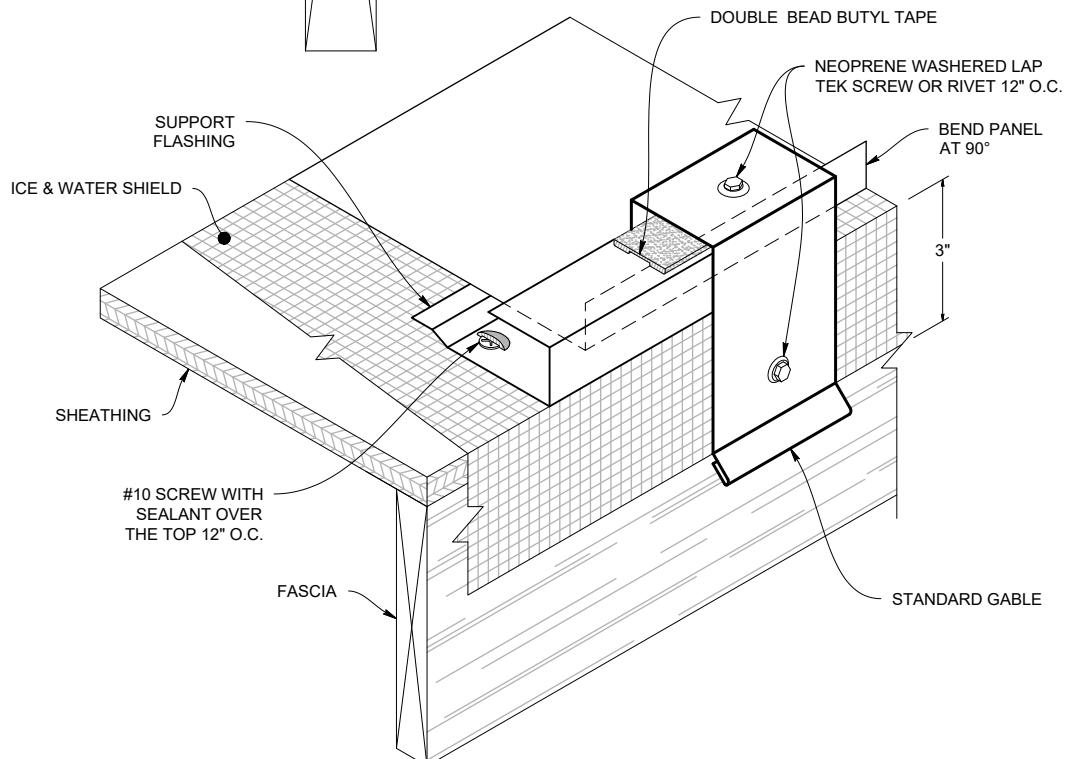
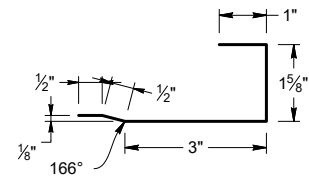

Note: All screws must be fastened into solid substrate.
Flashing must be lapped 4" with 3 rows of gunnable butyl.

Alternate Gable

ALTERNATE L CLOSURE (CLALC)

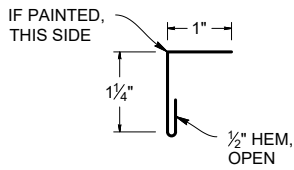

SUPPORT FLASHING (CLSF)

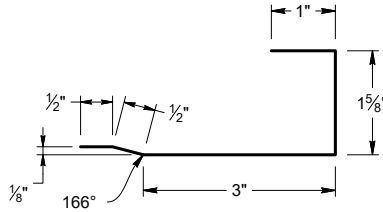

ALTERNATE GABLE (CLGA)

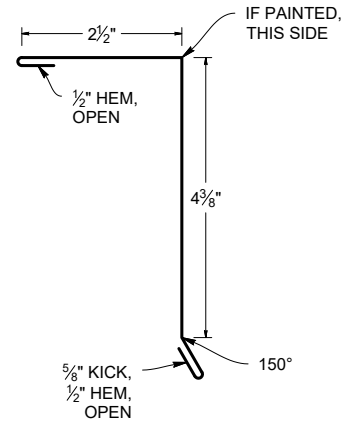

ALTERNATE GABLE DETAIL

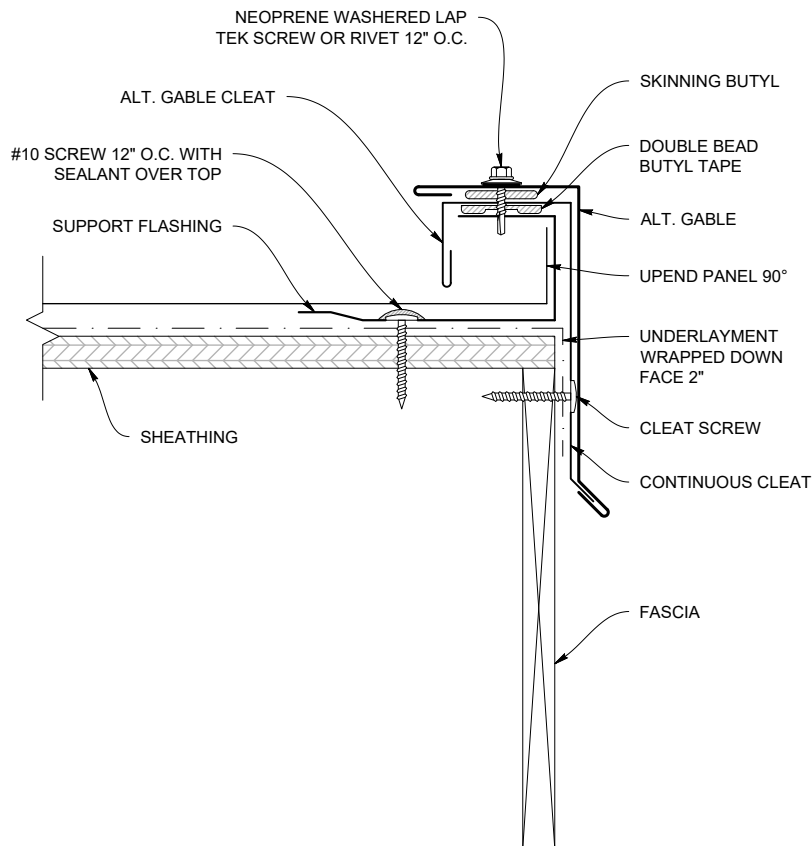

GABLE SUPPORT CLEAT (CLGC)

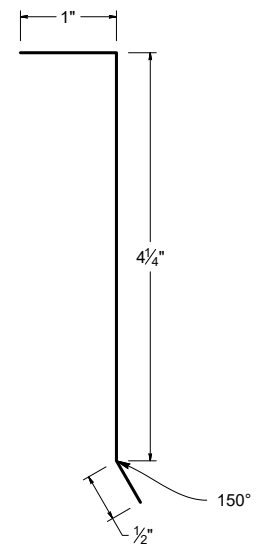

Note: All screws must be fastened into solid substrate.
Flashing must be lapped 4" with 3 rows of gunnable butyl.

SIDEWALL DETAIL

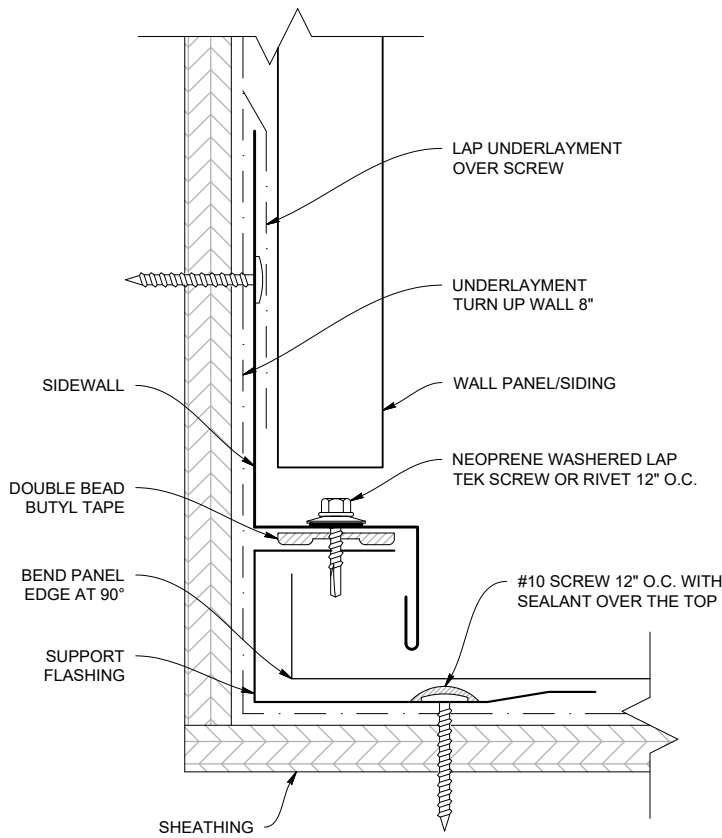

SIDEWALL (CLSW)

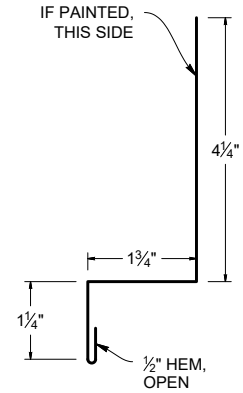

SUPPORT FLASHING (CLSF)

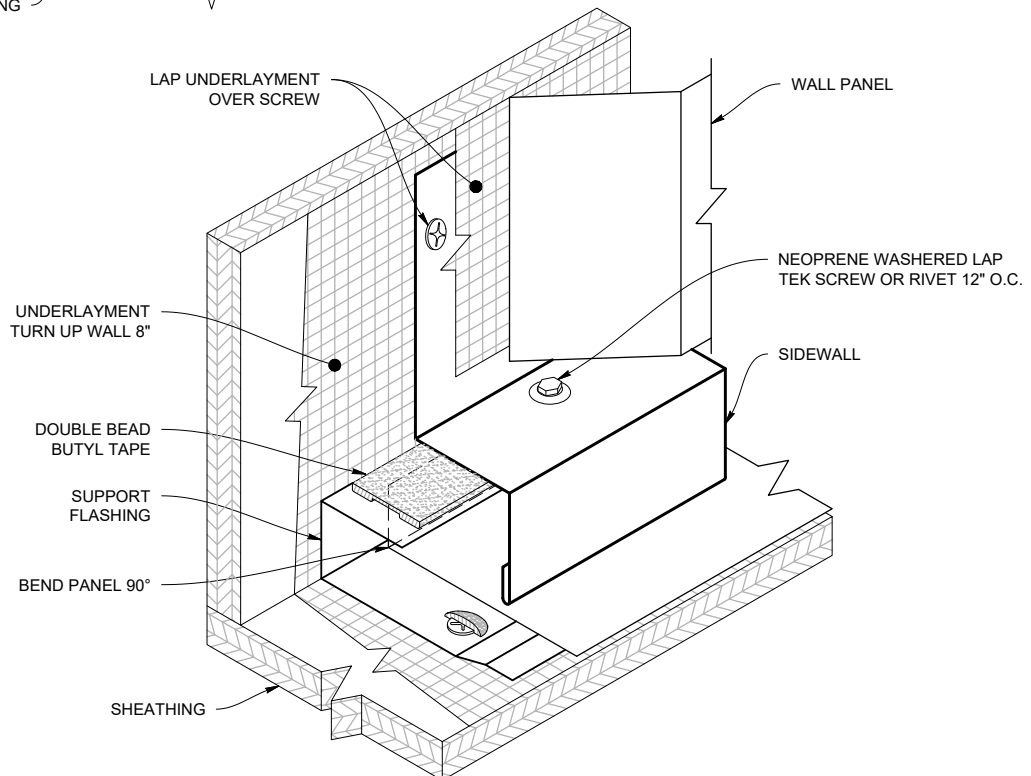
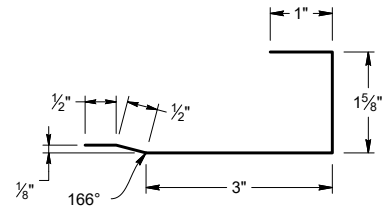

Note: All screws must be fastened into solid substrate.
Flashing must be lapped 4" with 3 rows of gunnable butyl.

Peak Flashing

(Ridge End Cap)

PEAK FLASHING DETAIL (Ridge End Cap)

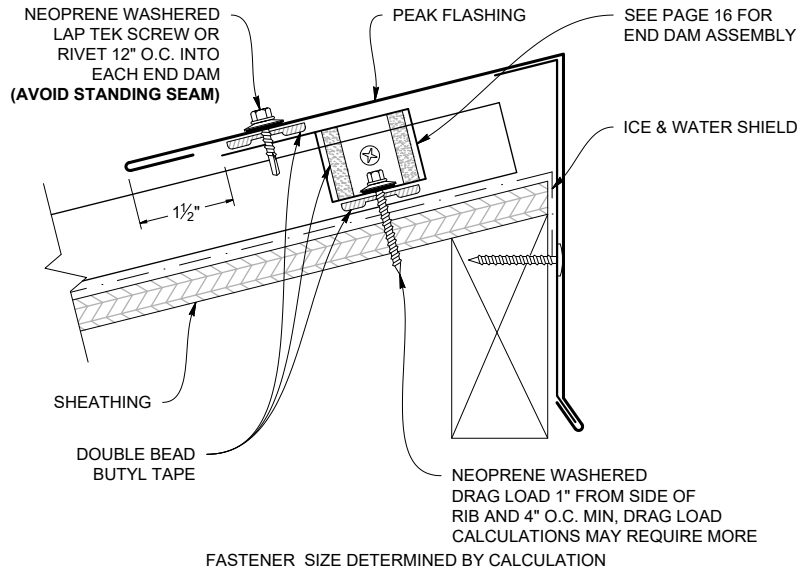

PEAK FLASHING (Ridge End Cap) (CLREC)

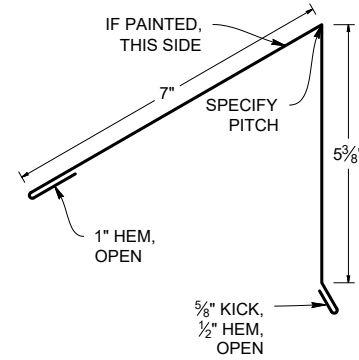

PEAK CLEAT (CLRECC)

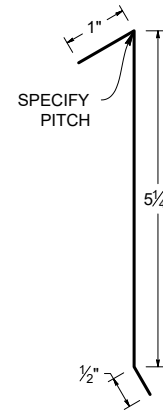

PEAK FLASHING LAP

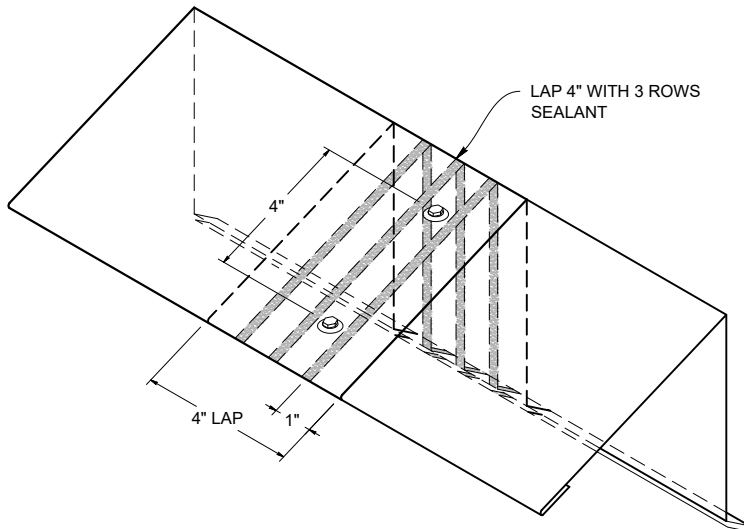

Note: All screws must be fastened into solid substrate.
Flashing must be lapped 4" with 3 rows of gunnable butyl.

PITCH CHANGE DETAIL

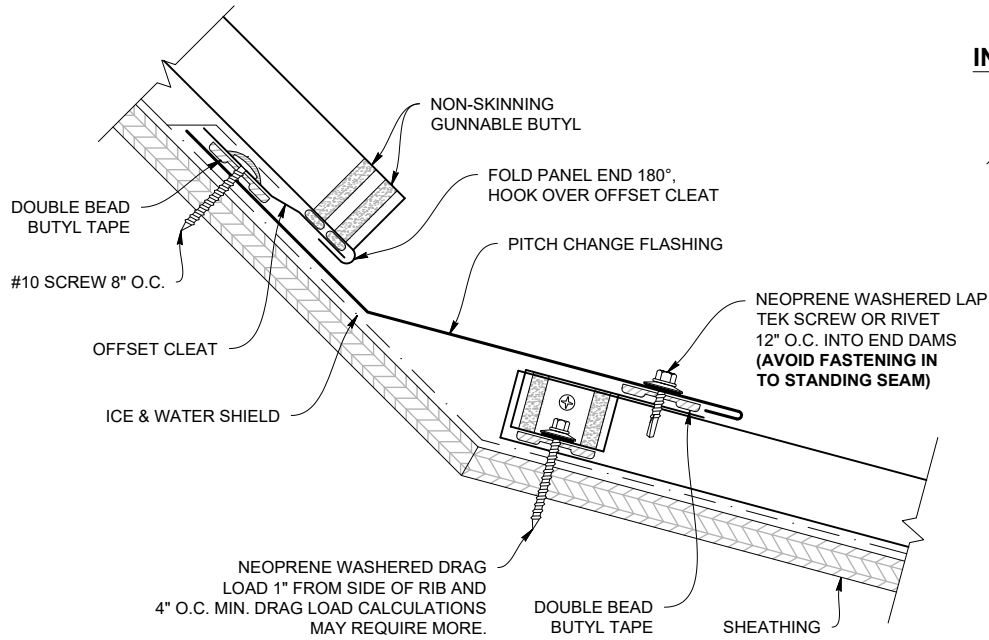

INSIDE PITCH CHANGE FLASHING

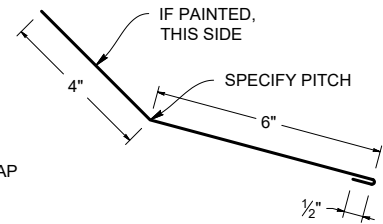

OFFSET CLEAT (CLOC)

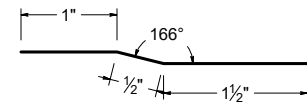

PITCH CHANGE LAP

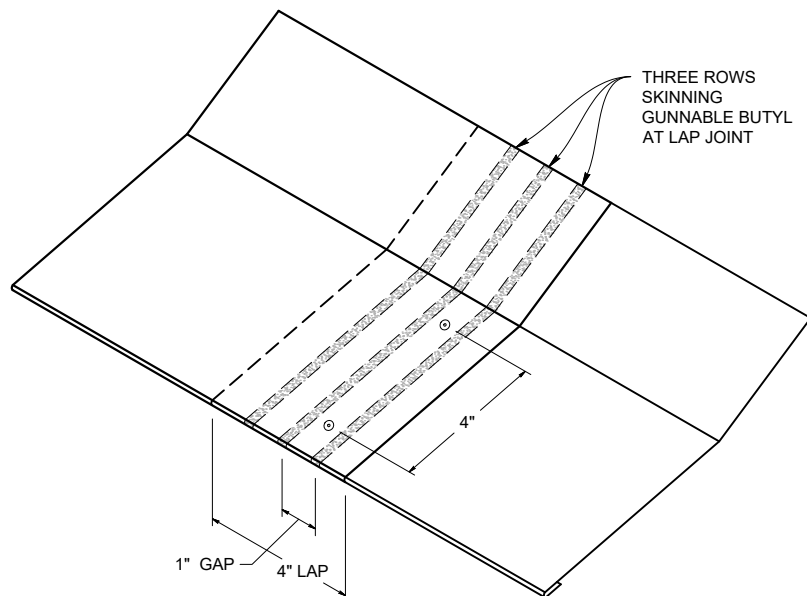

Note: All screws must be fastened into solid substrate.
Flashing must be lapped 4" with 3 rows of gunnable butyl.

ENDWALL DETAIL

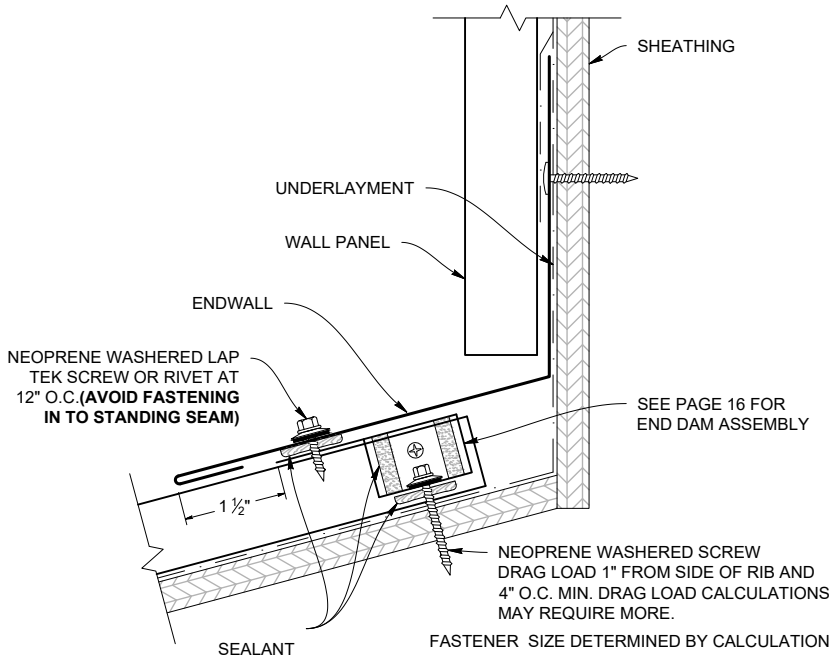

ENDWALL FLASHING (CLEW)

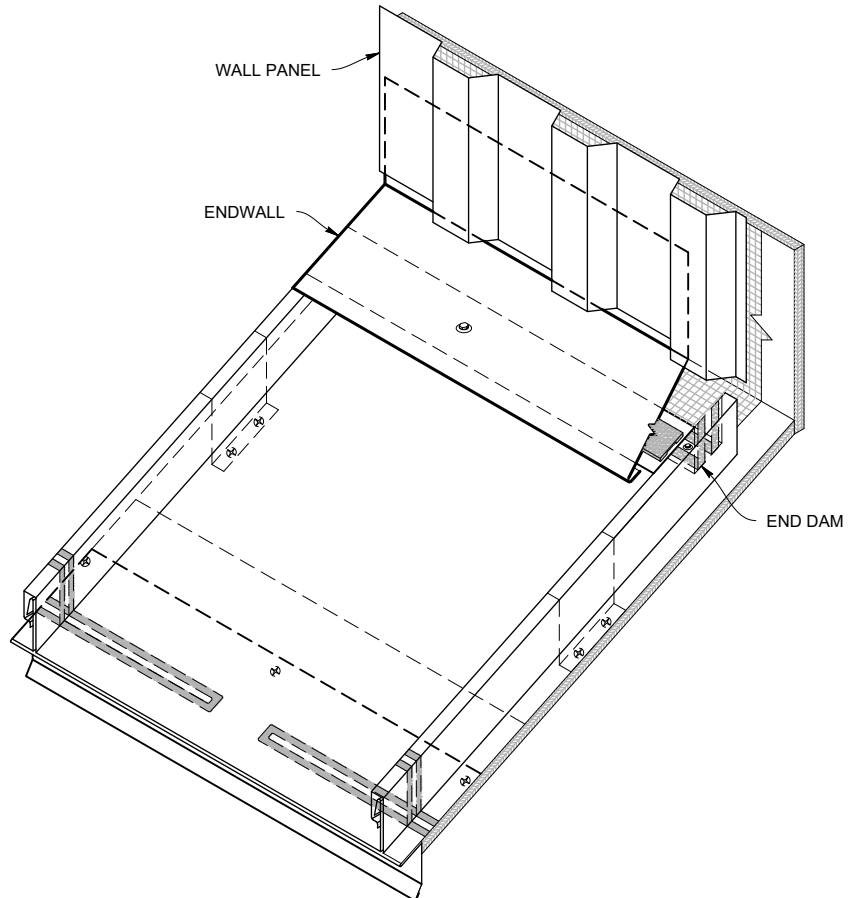
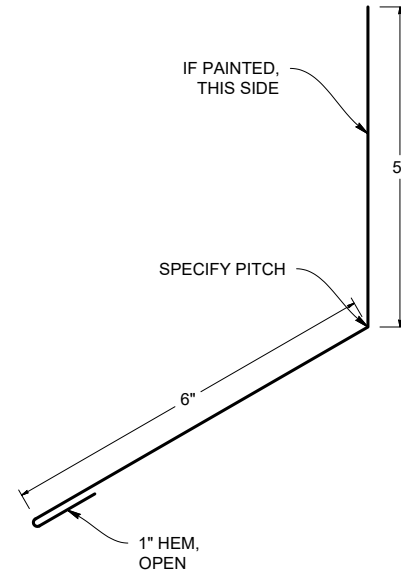

Note: All screws must be fastened into solid substrate.
Flashing must be lapped 4" with 3 rows of gunnable butyl.

VENTED ENDWALL DETAIL

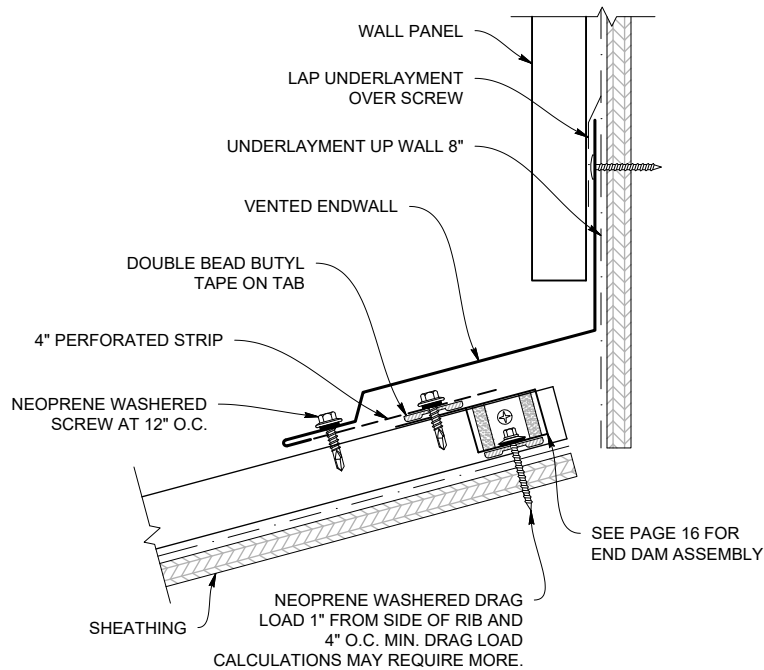

VENTED ENDWALL FLASHING (CLEVV)

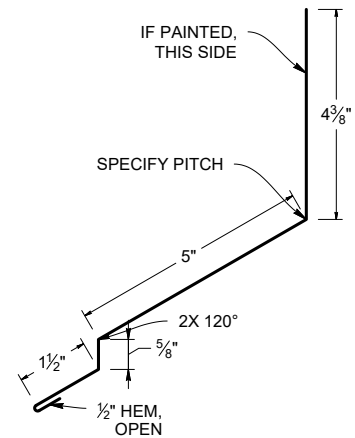

ENDWALL LAP

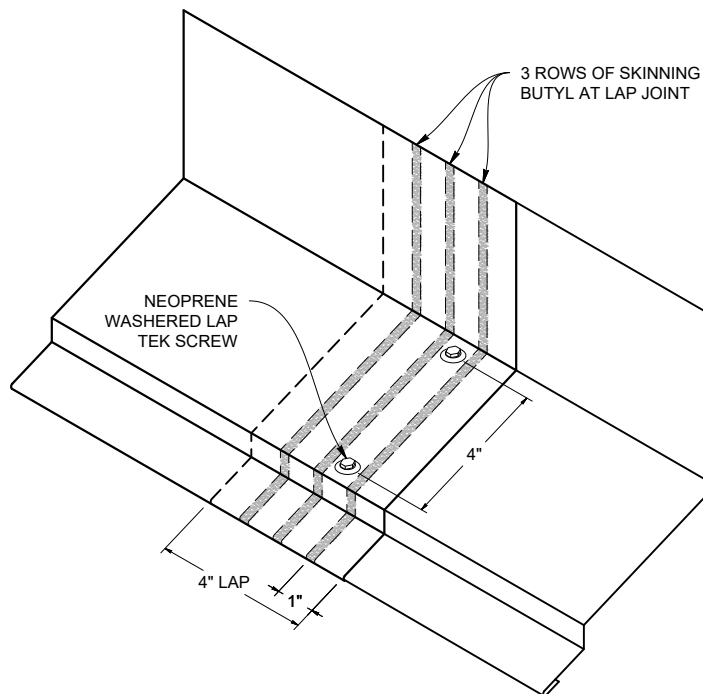

Note: All screws must be fastened into solid substrate.
Flashing must be lapped 4" with 3 rows of gunnable butyl.

Curb Back Pan / Cricket

STEP 1

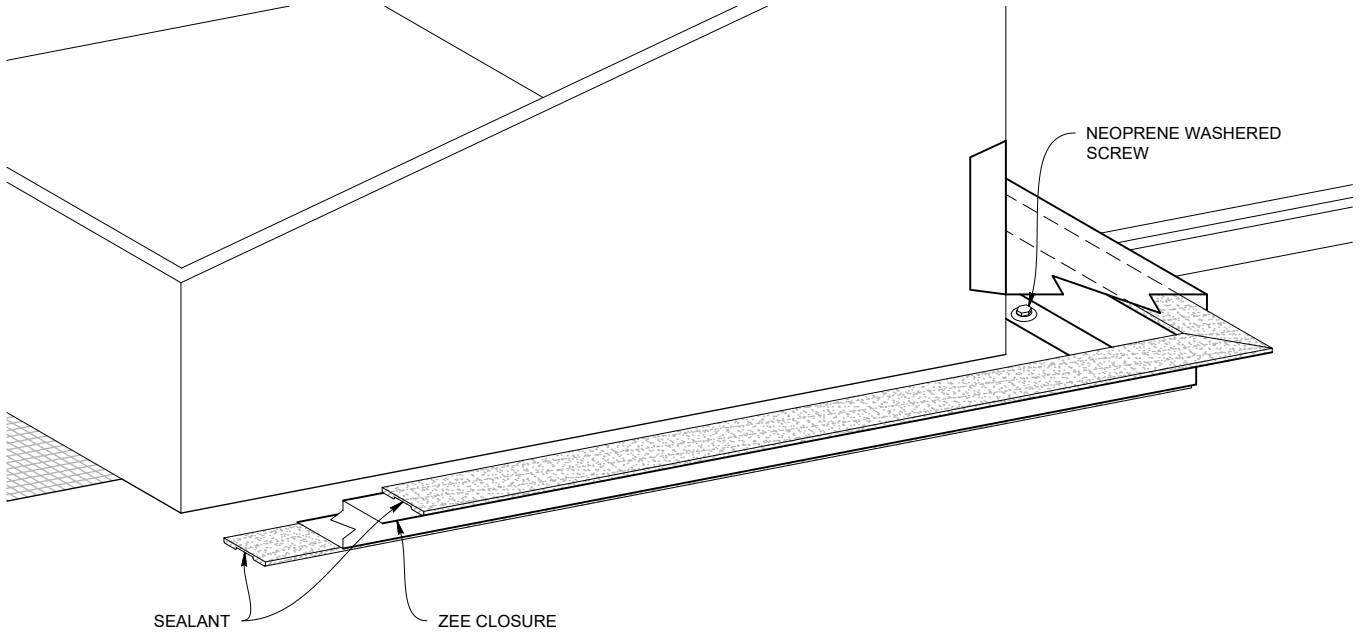

STEP 2

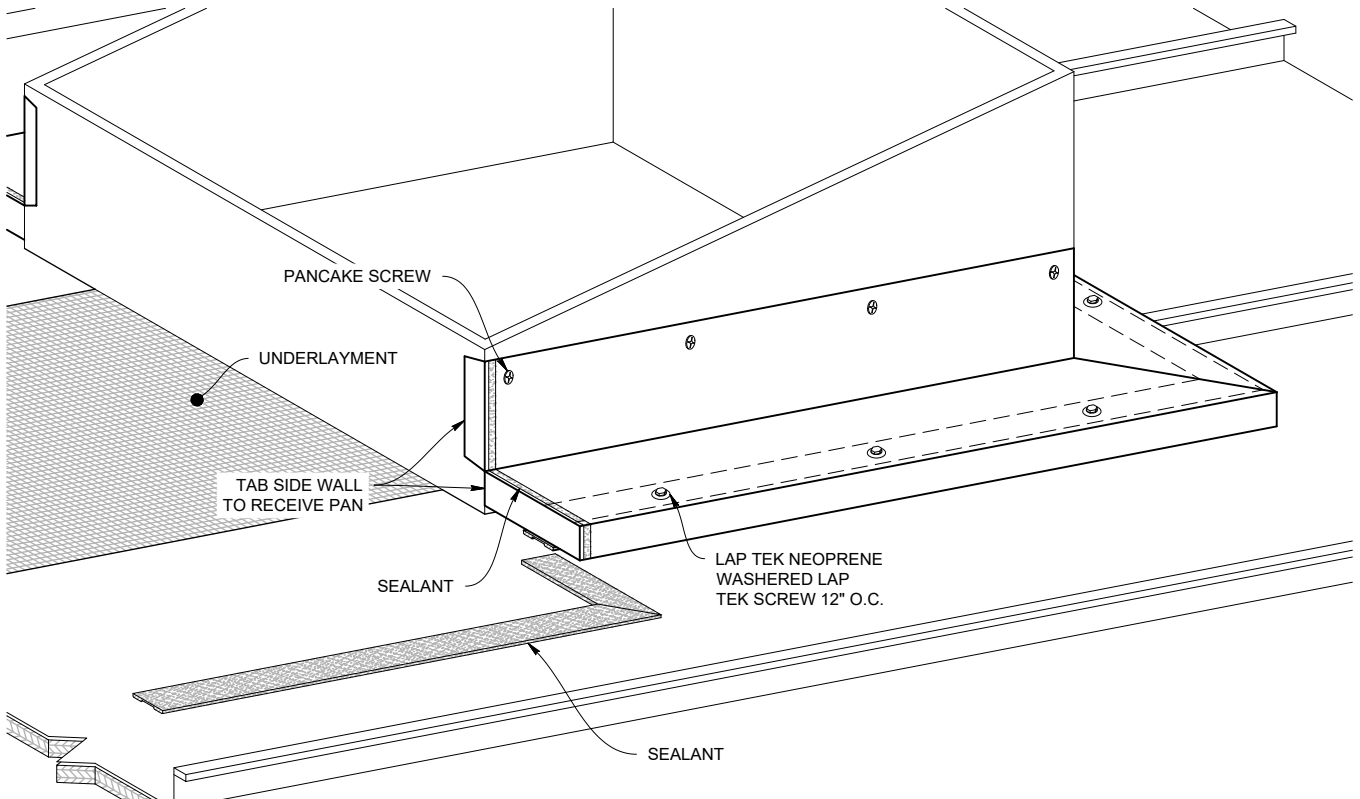

STEP 3

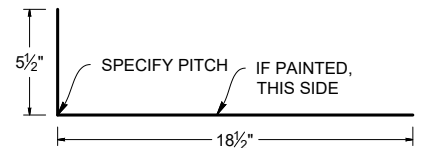
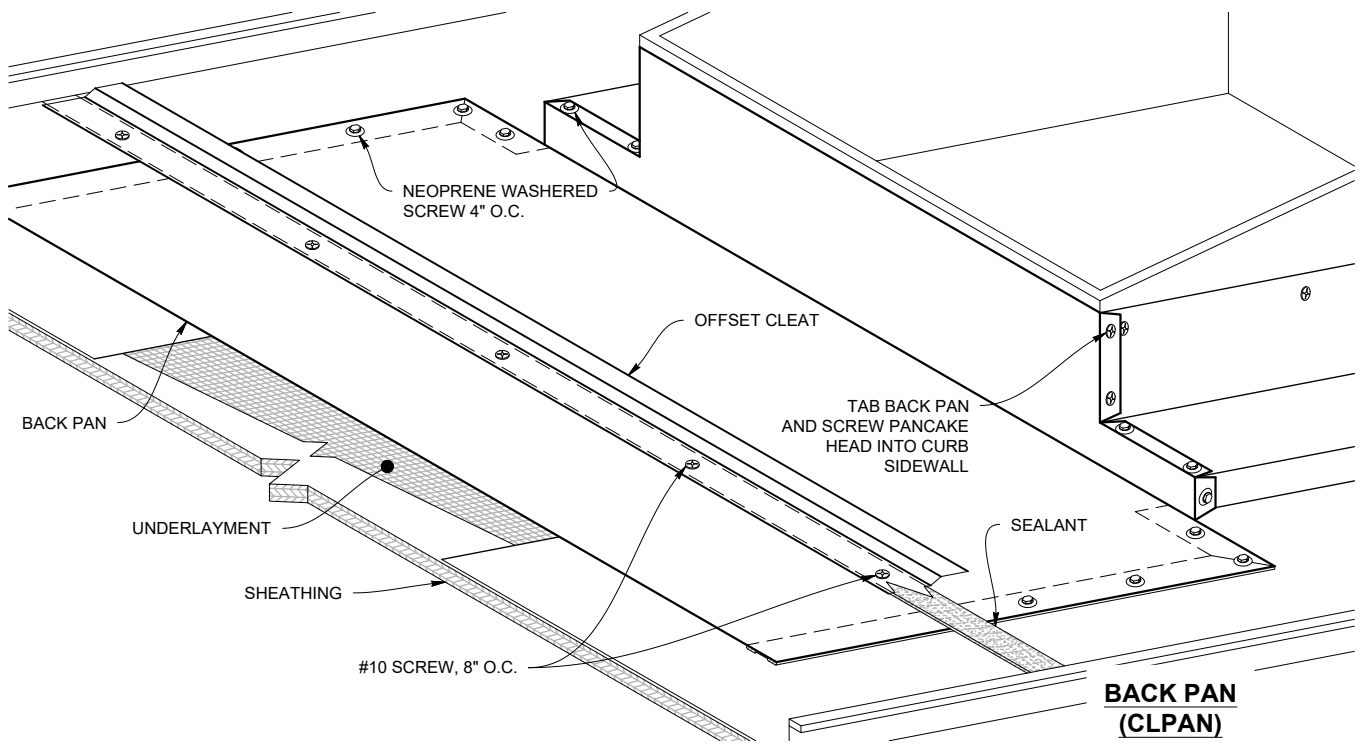

STEP 4

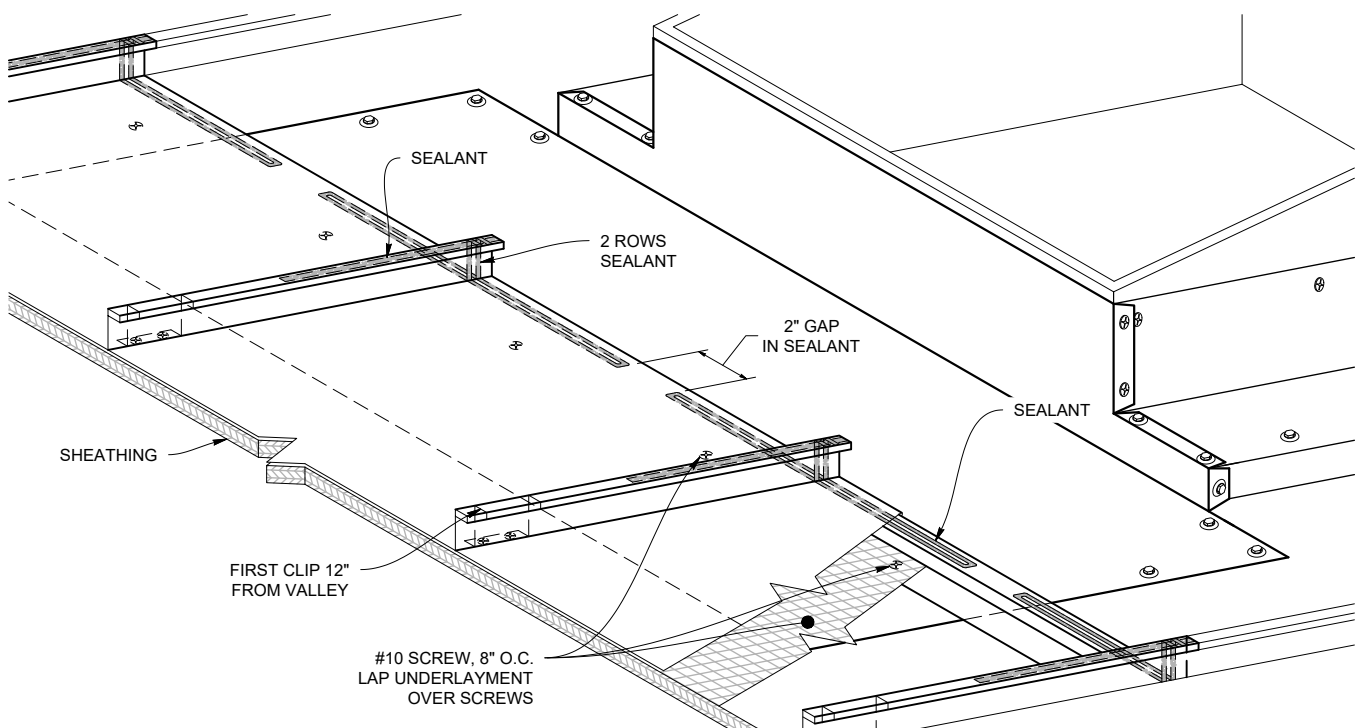

Curb Back Pan / Cricket

STEP 5

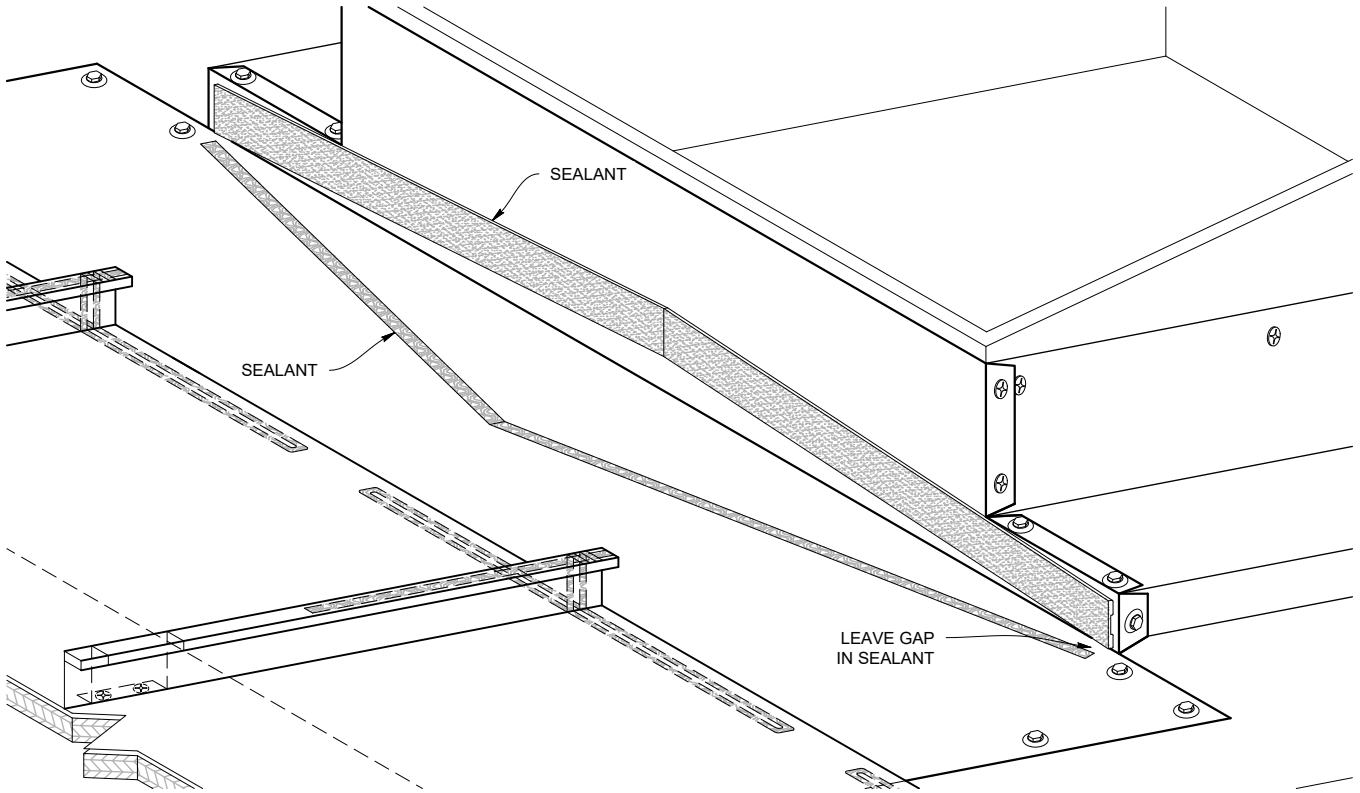

STEP 6

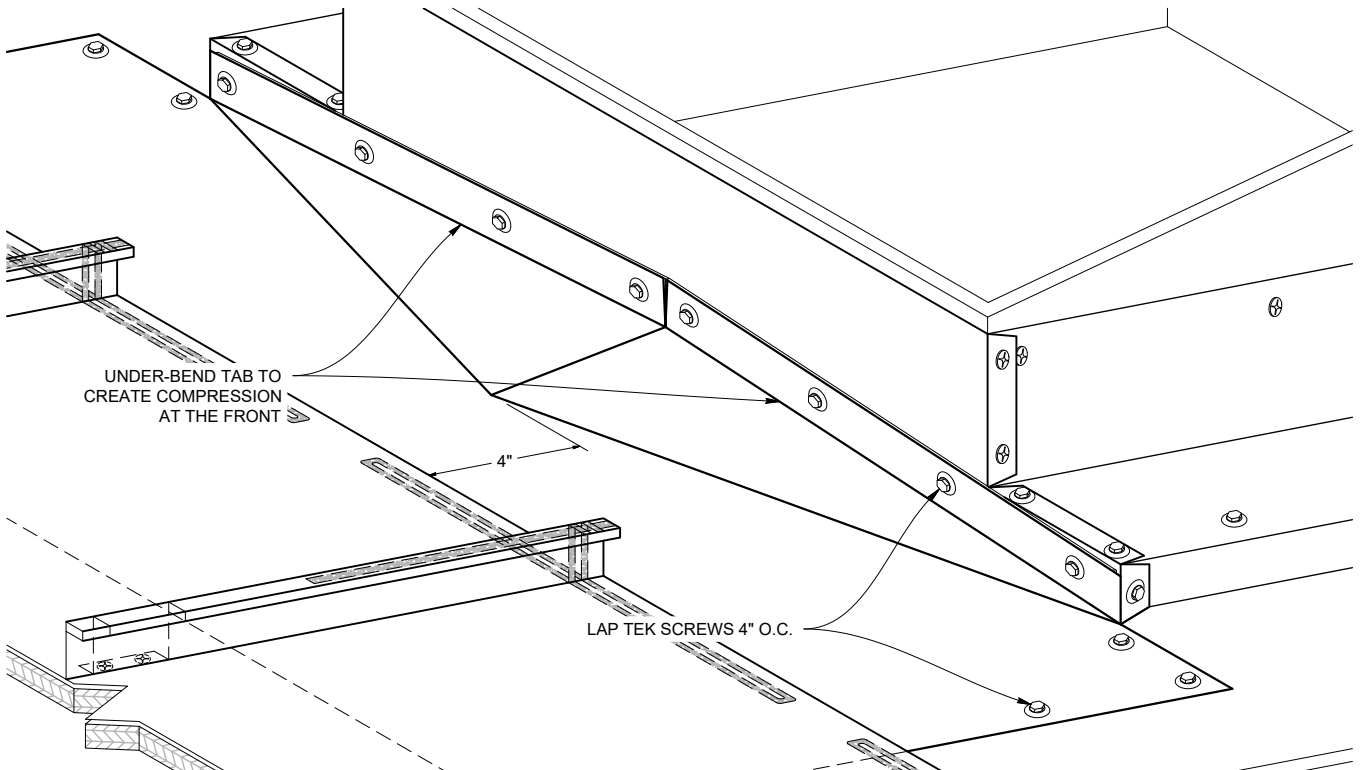

CURB SIDEWALL DETAIL

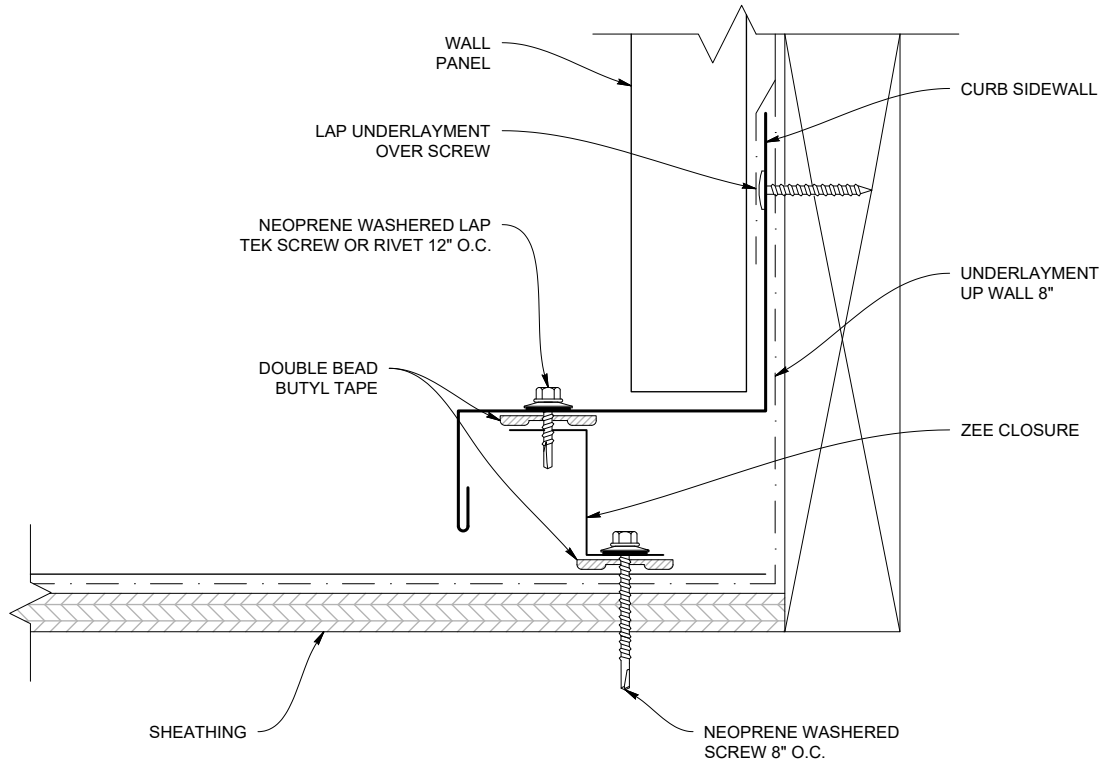

ZEE CLOSURE (CLZC)

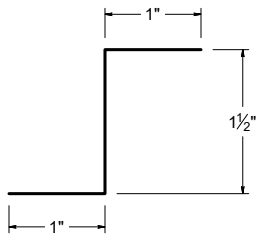

CURB SIDEWALL (CLCSW)

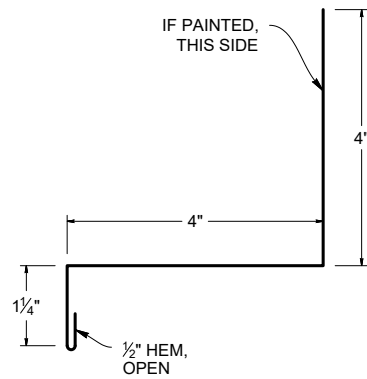

Note: All screws must be fastened into solid substrate.
Flashing must be lapped 4" with 3 rows of gunnable butyl.

CURB ENDWALL DETAIL

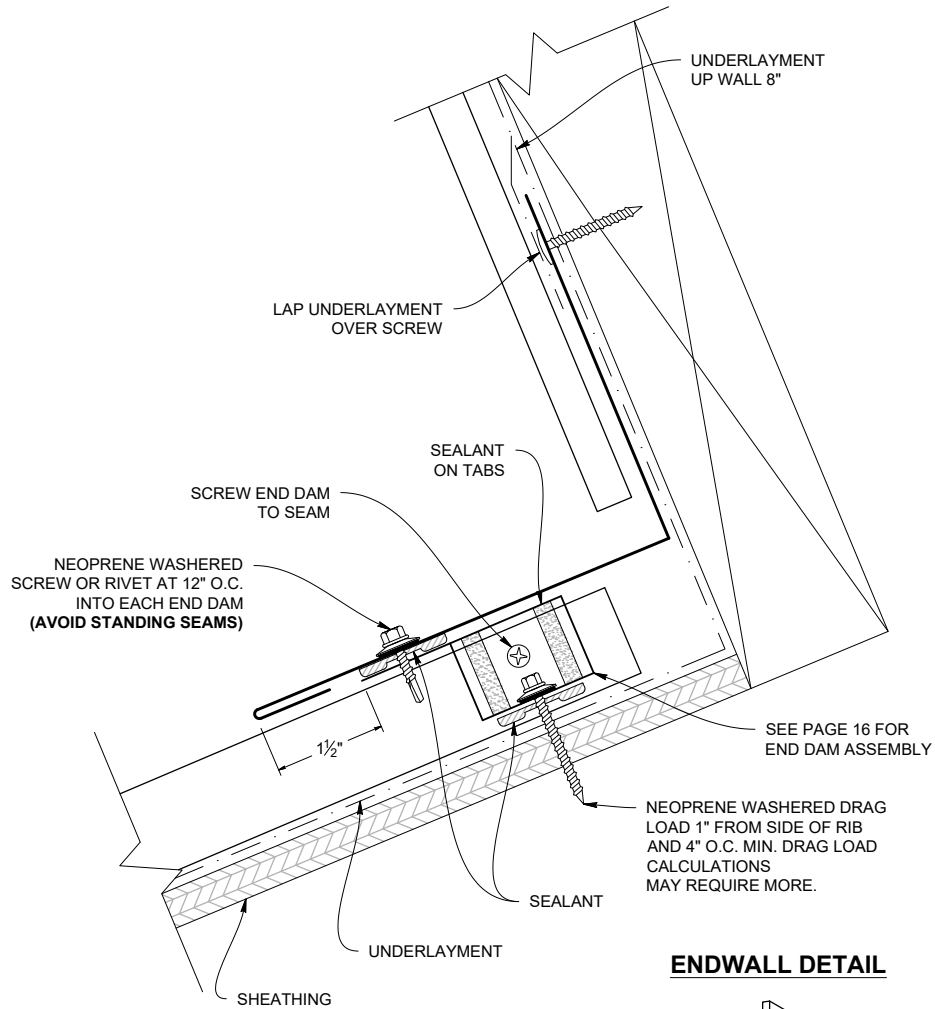

ENDWALL DETAIL

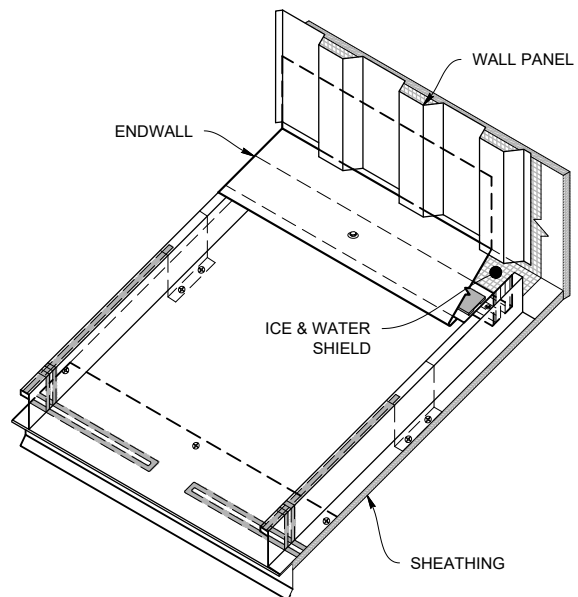

CURB ENDWALL (CLCH)

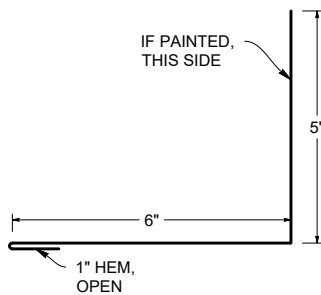

Note: All screws must be fastened into solid substrate.
Flashing must be lapped 4" with 3 rows of gunnable butyl.

CURB BACK PAN / CRICKET DETAIL (3:12 Pitch or Greater)

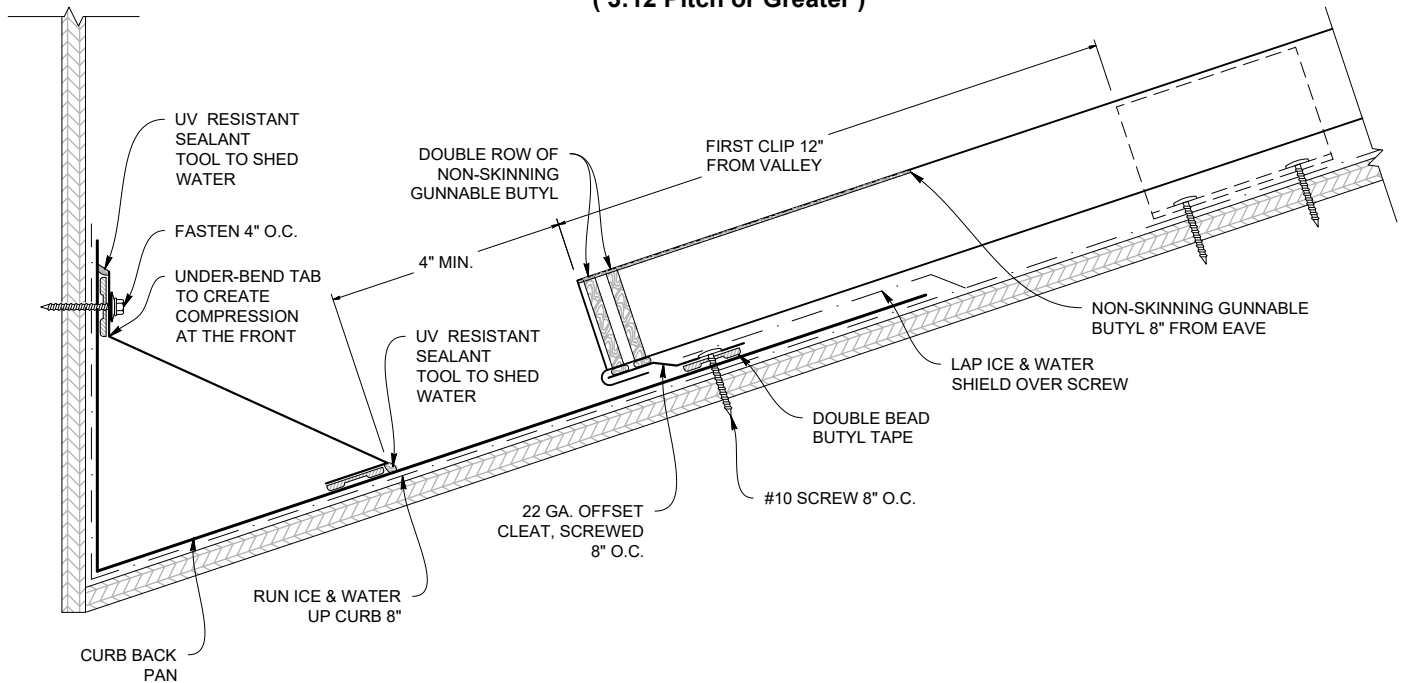

CURB BACK PAN / CRICKET DETAIL (Less Than 3:12 Pitch)

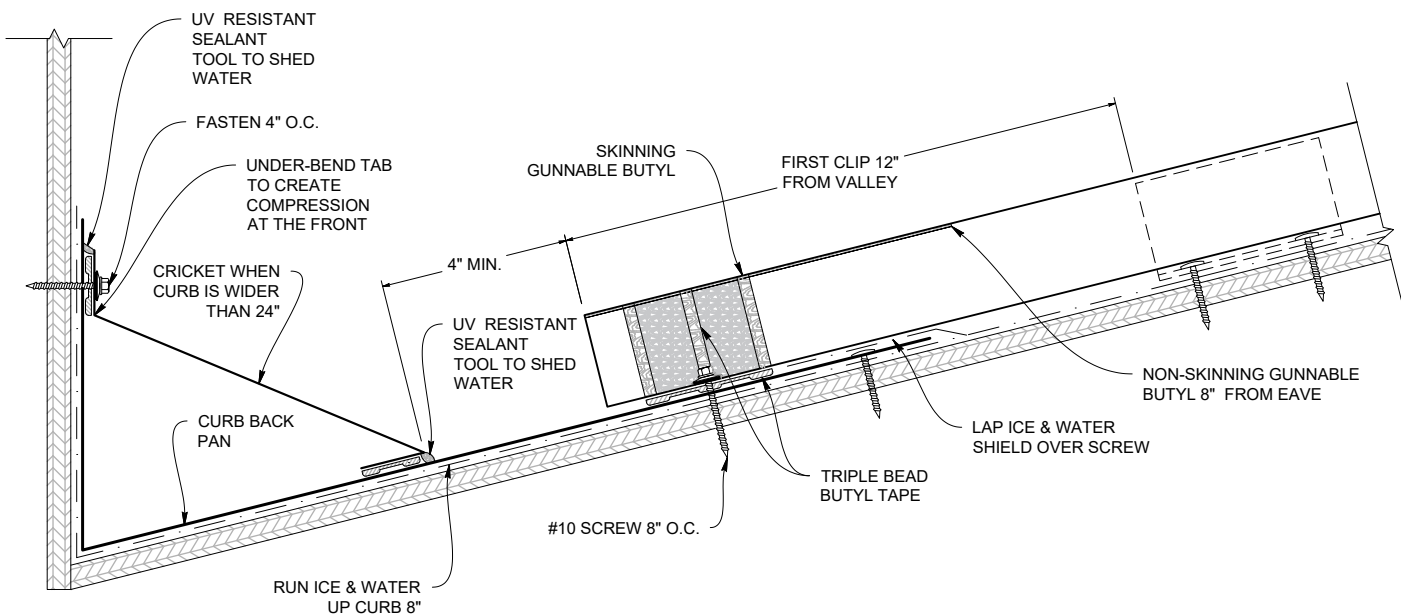

Note: All screws must be fastened into solid substrate.
Flashing must be lapped 4" with 3 rows of gunnable butyl.

Eave to Gable Transition



EAVE TO GABLE TRANSITION APPLICATION

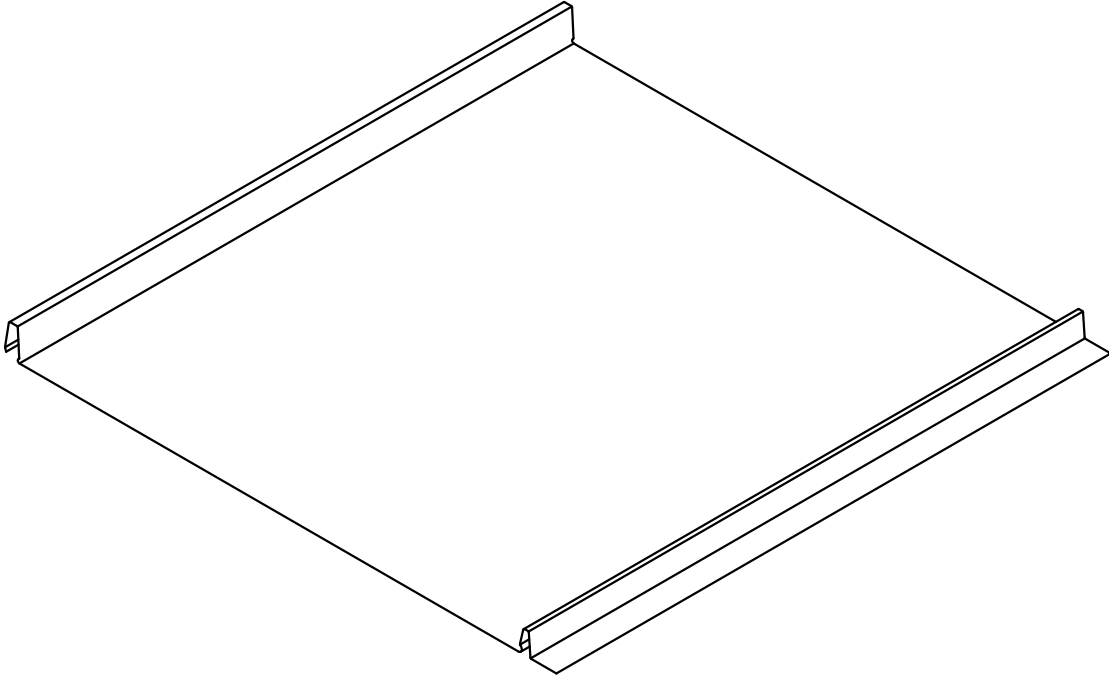

STEP 1

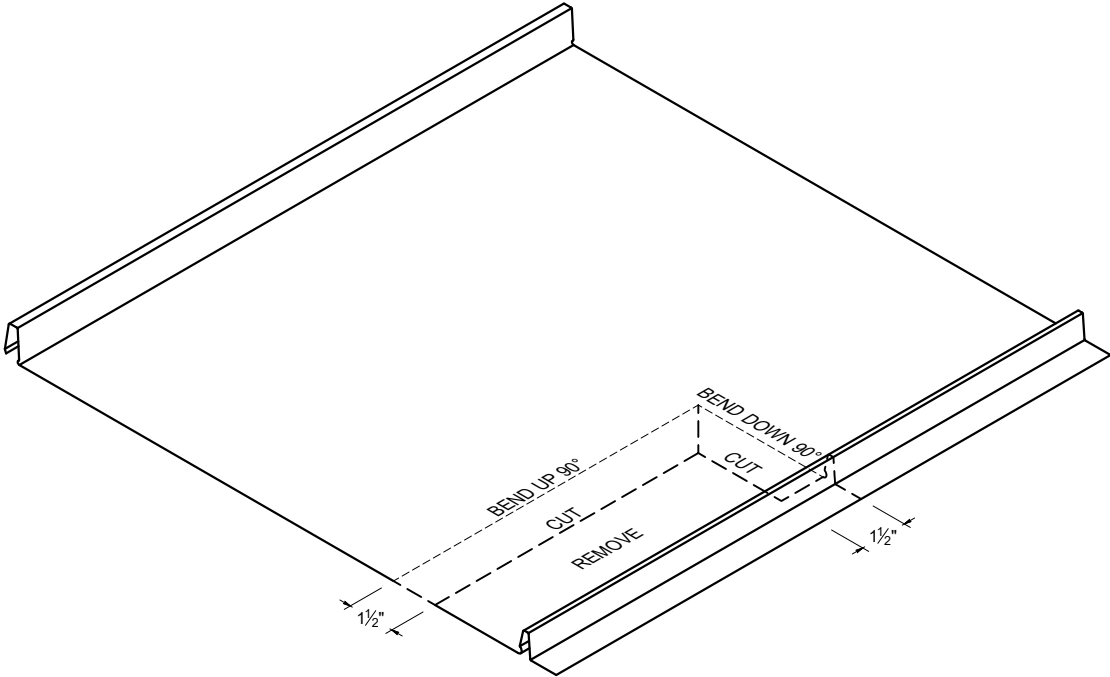

Note: All screws must be fastened into solid substrate.
Flashing must be lapped 4" with 3 rows of gunnable butyl.

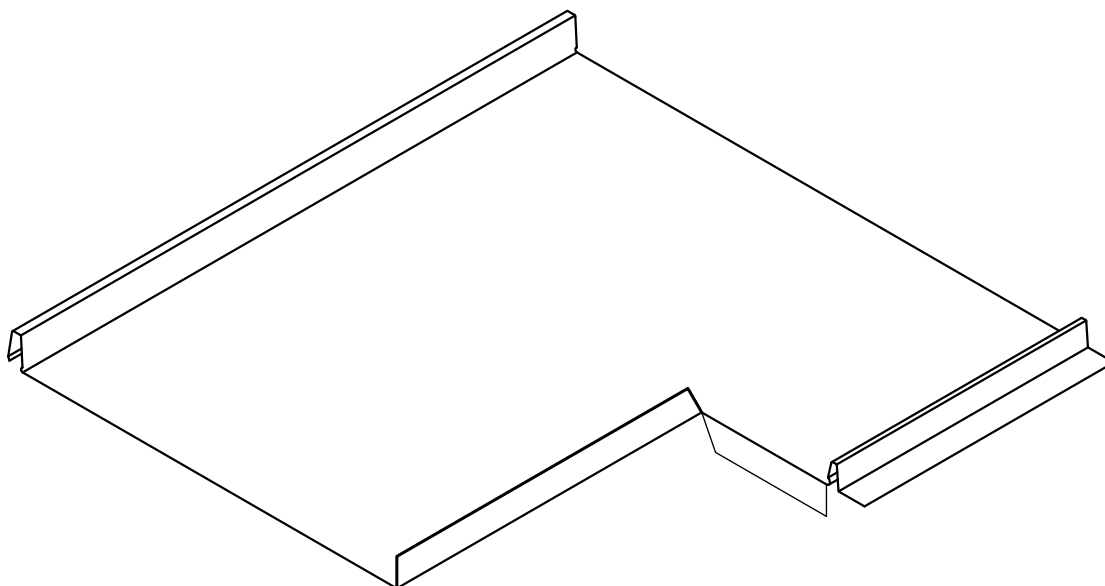

STEP 2

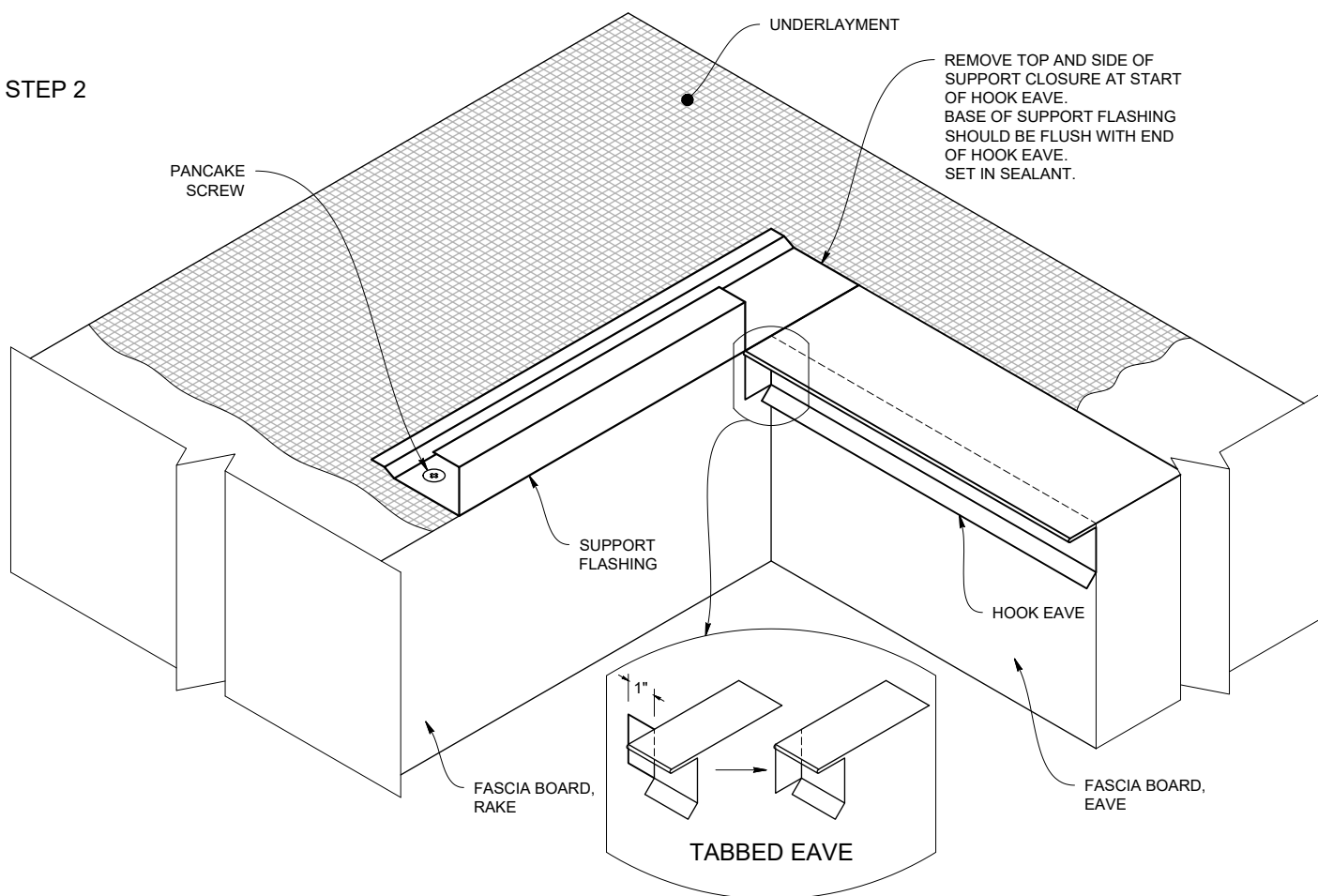

Eave to Gable Transition

STEP 3

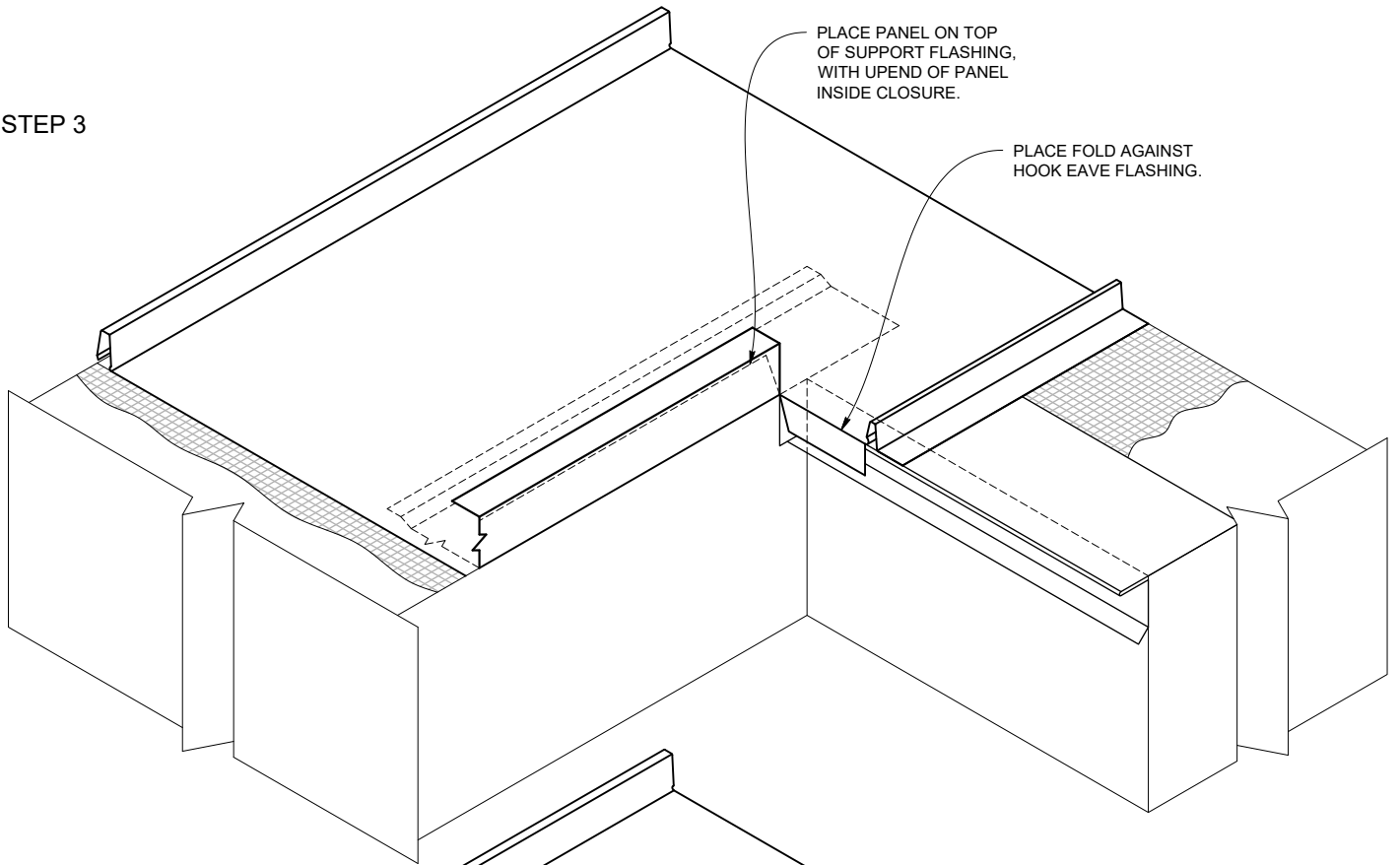

STEP 4

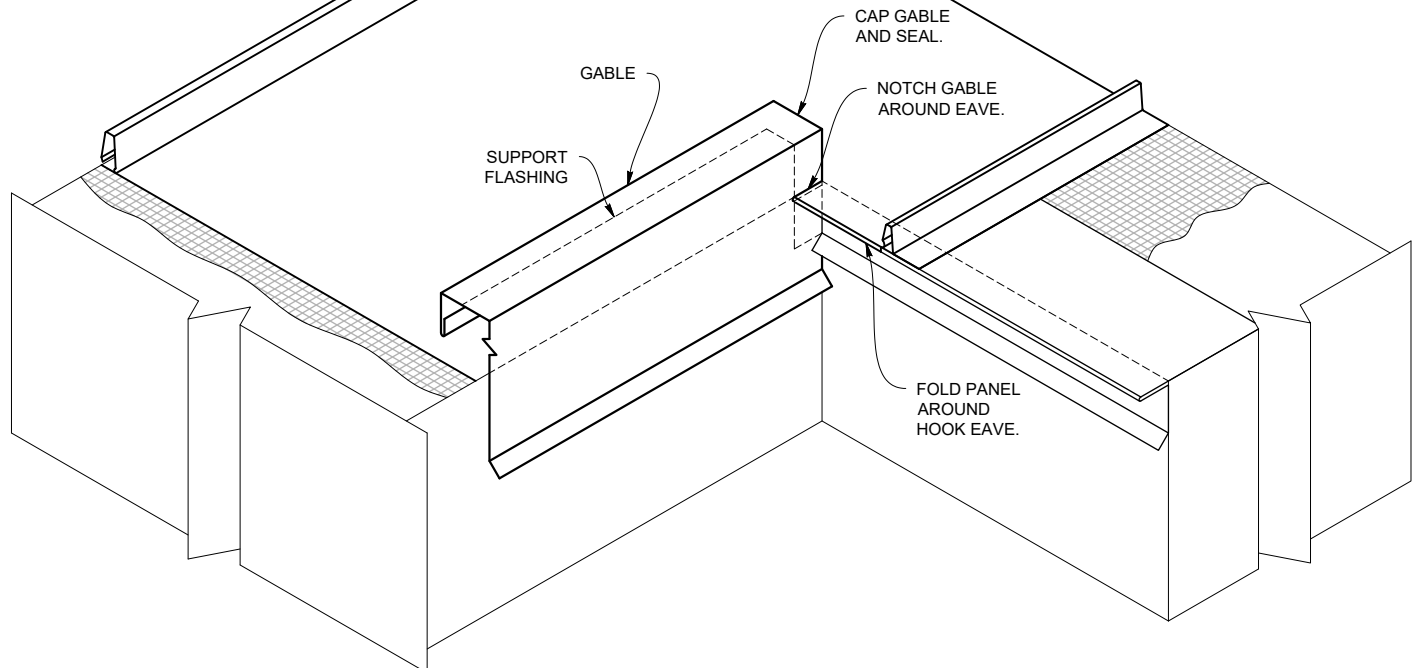

FOR PIPES LOCATED GREATER THAN 20' FROM PIN POINT

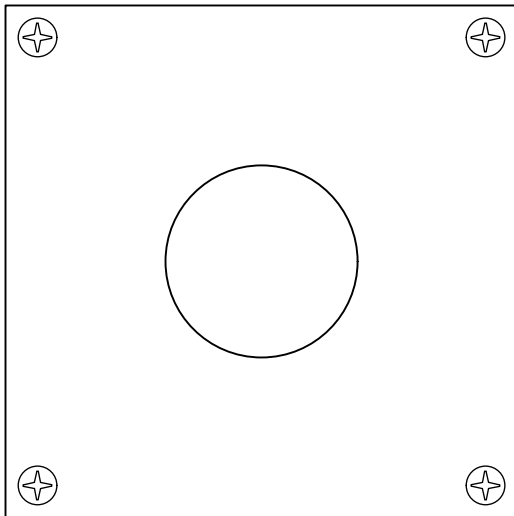
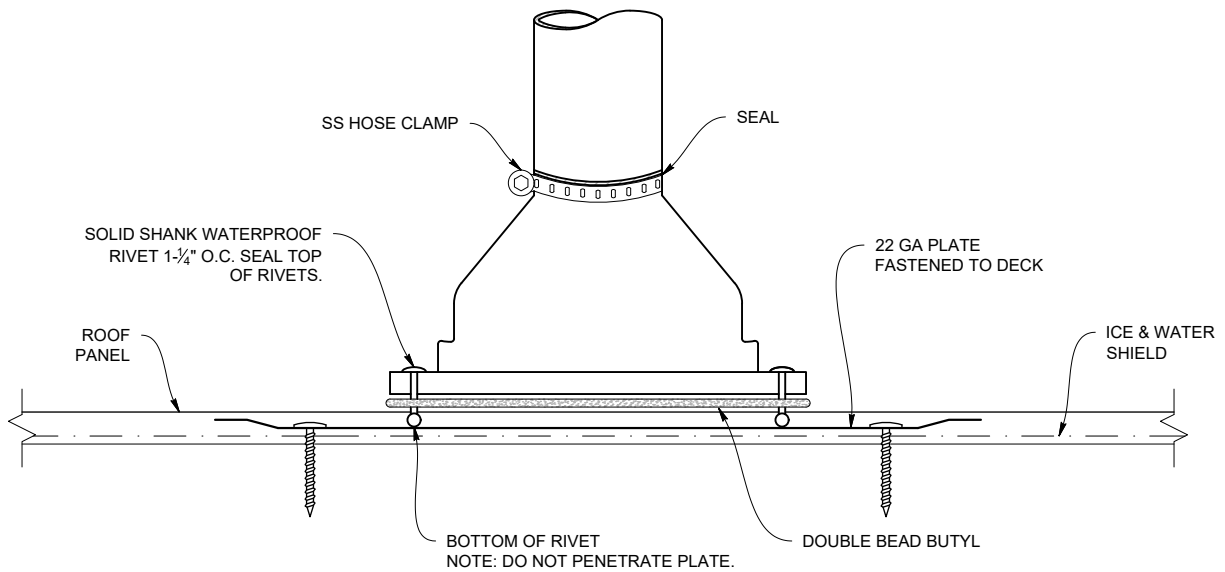

SINGLE 22 GAUGE PLATE

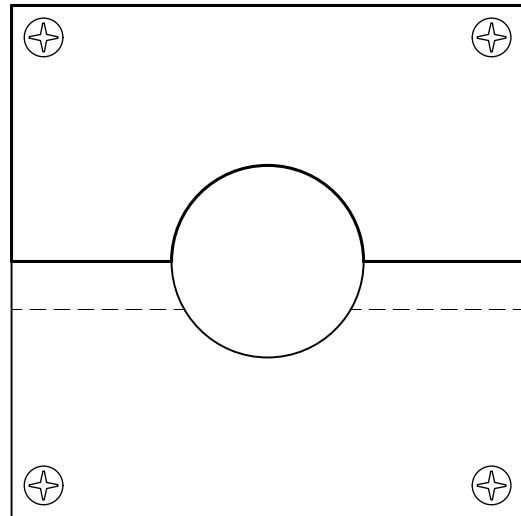

TWO OVERLAPPING 22 GAUGE PLATES

Pipe Penetration - on Rib

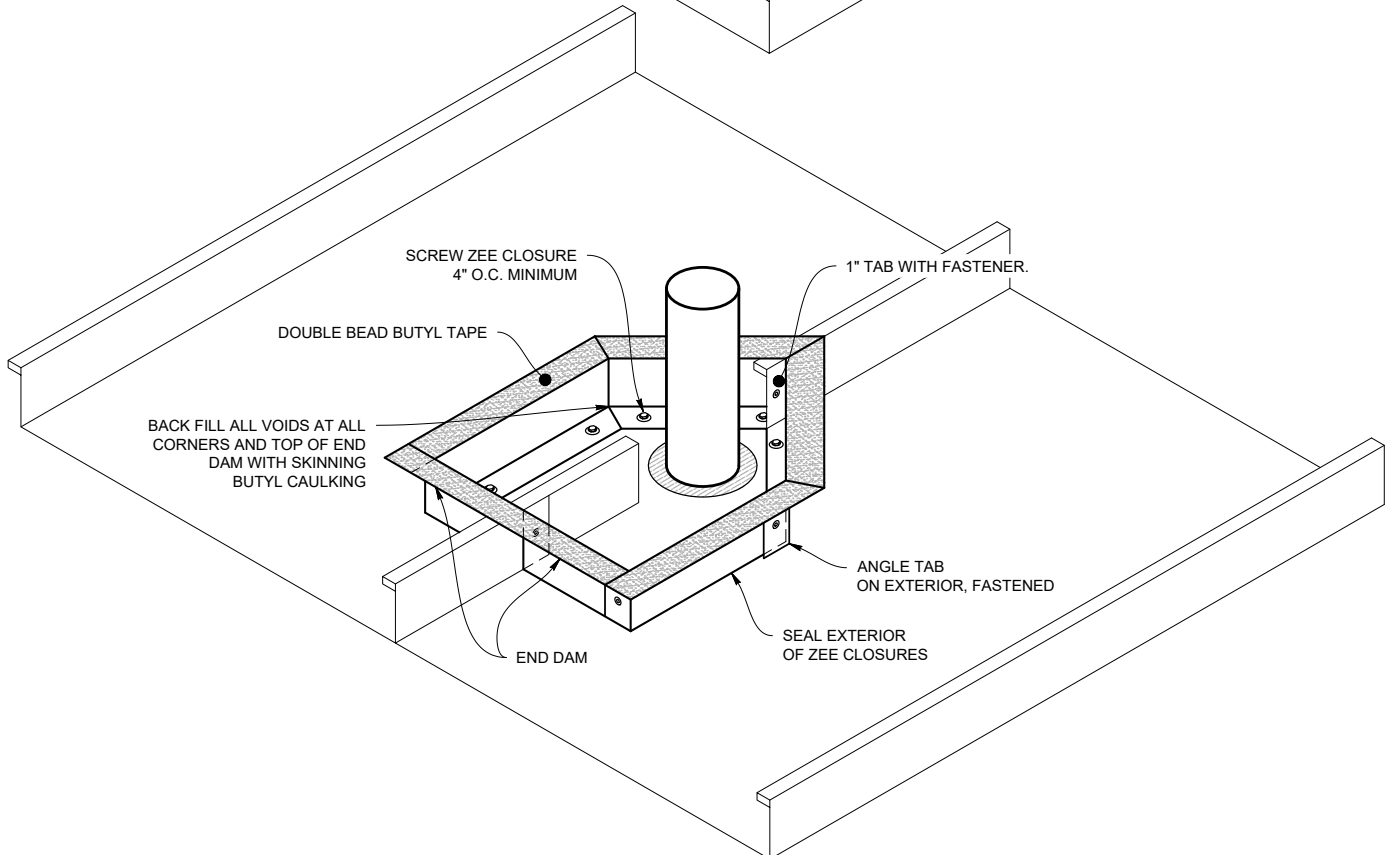
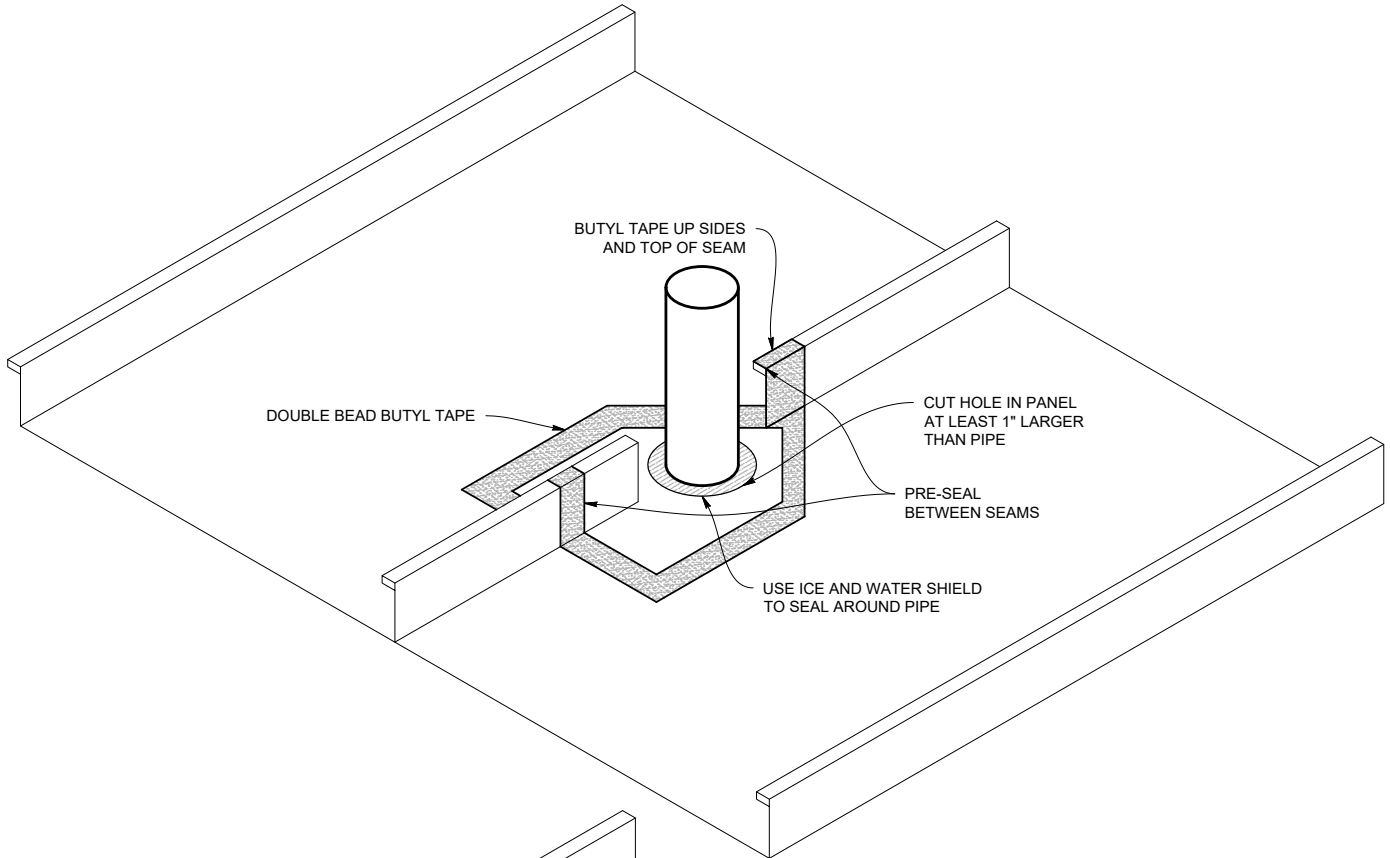

Pipe Penetration - on Rib

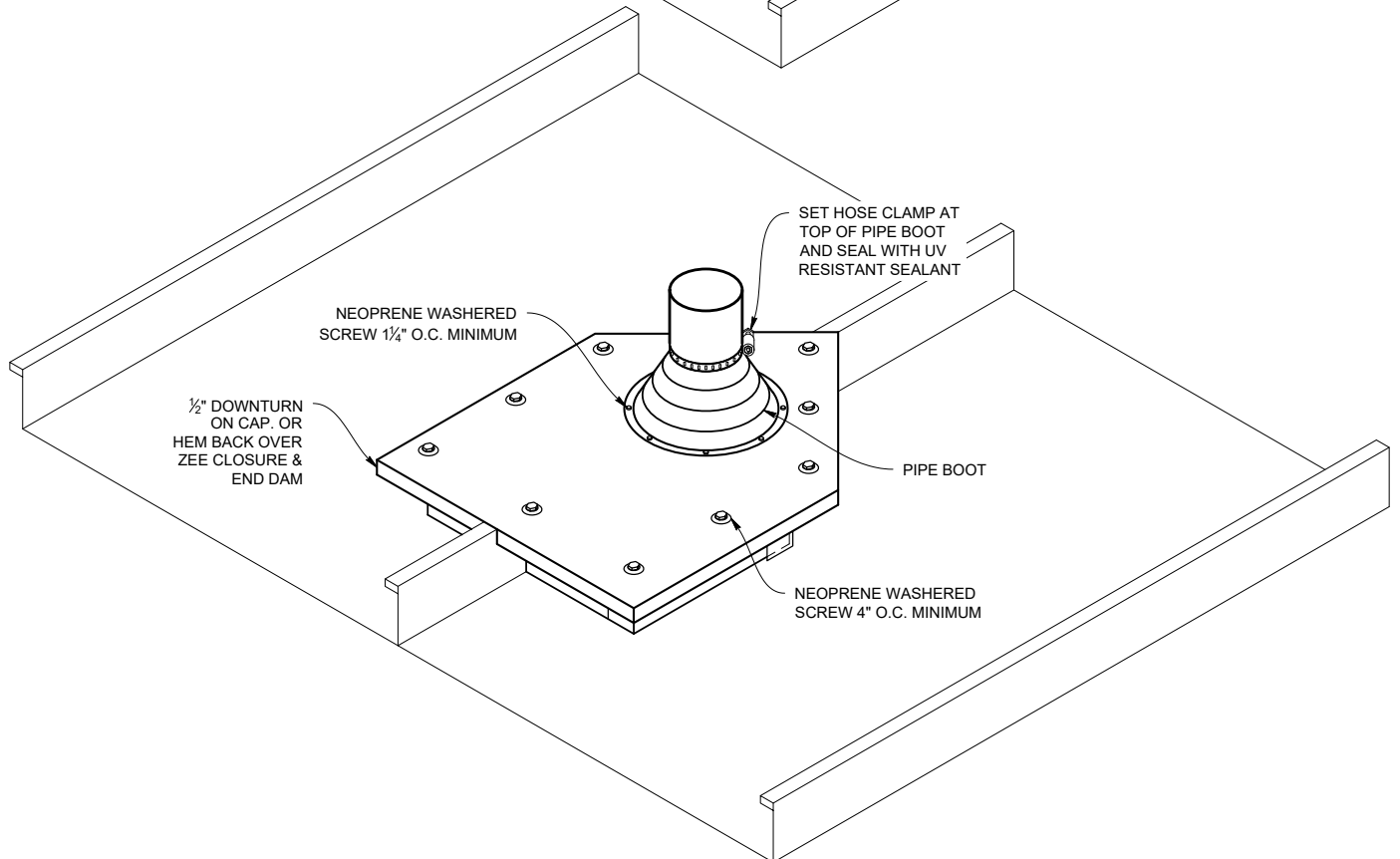
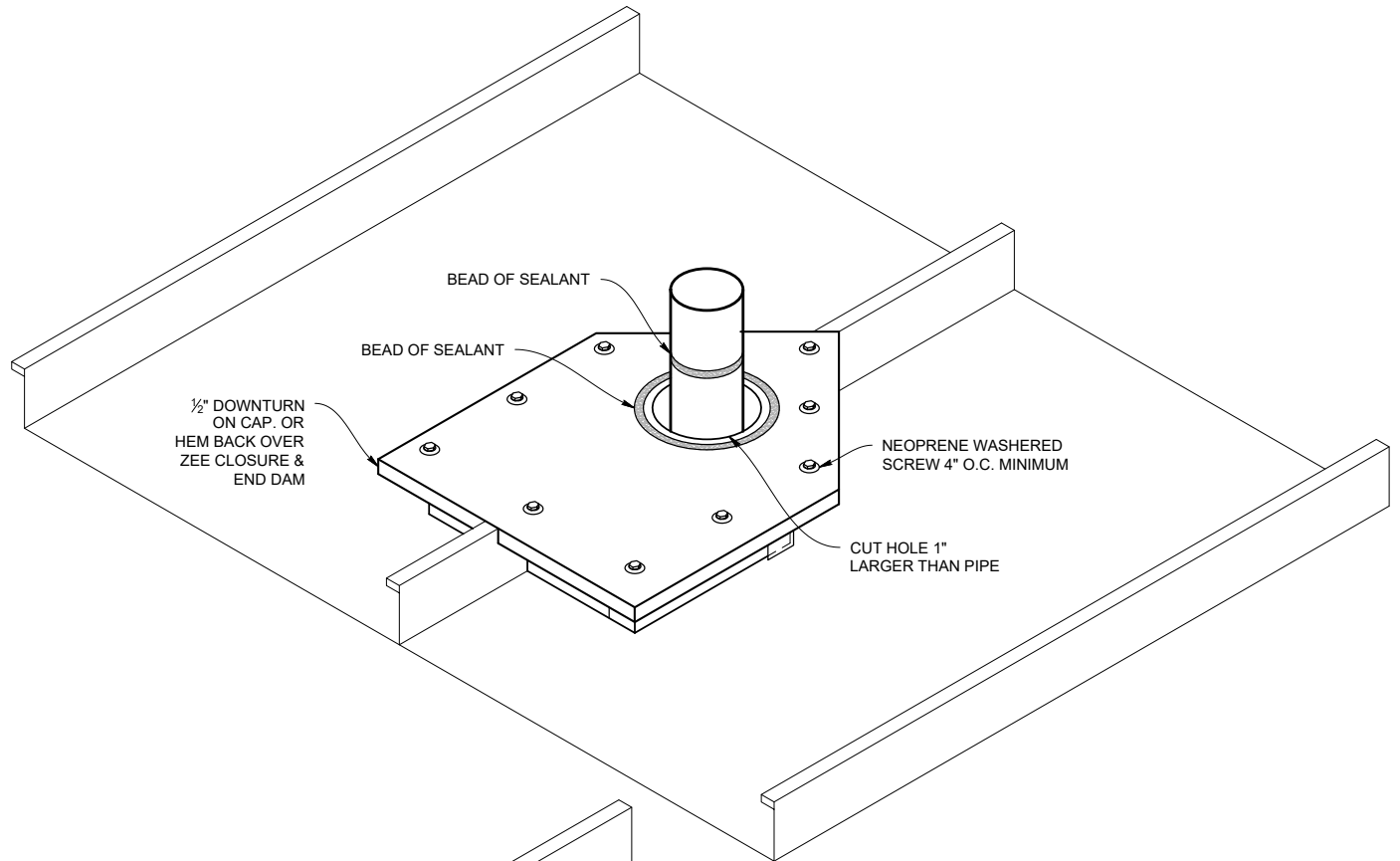

Pipe Penetration - on Pan

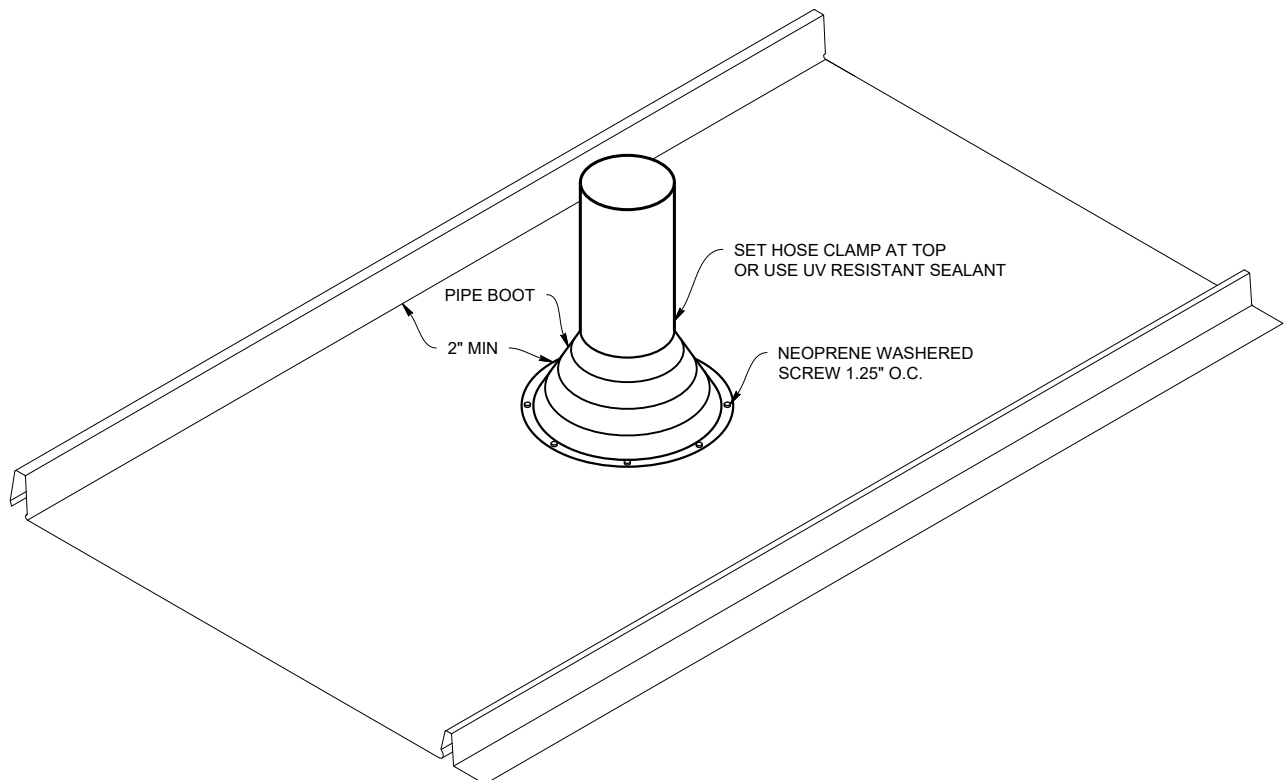
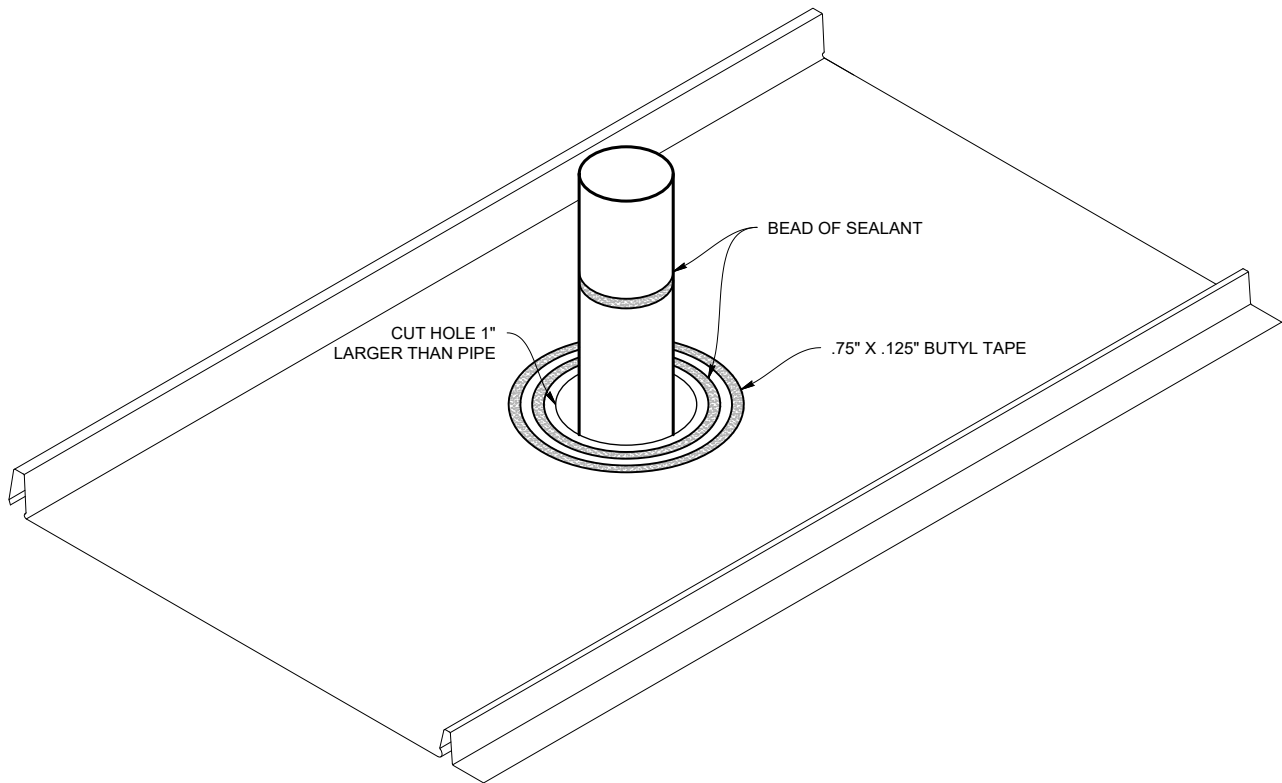

**STANDARD EAVE
(CLES)**

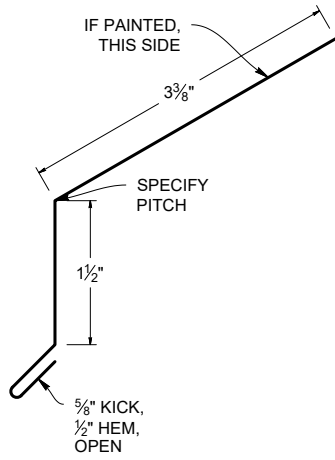

SCALE 1:2 S.O. 6" WEIGHT: 4.9 LBS.

**HOOK EAVE
(CLEH)**

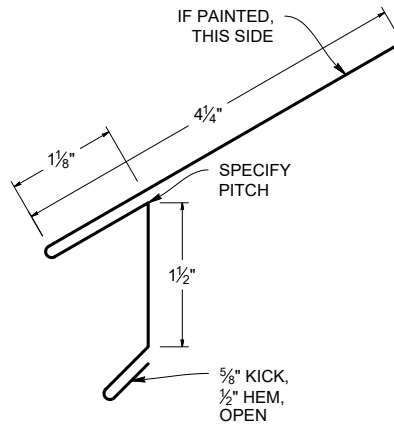

SCALE 1:2 S.O. 8" WEIGHT: 6.5 LBS.

**OFFSET CLEAT
(CLOC)**

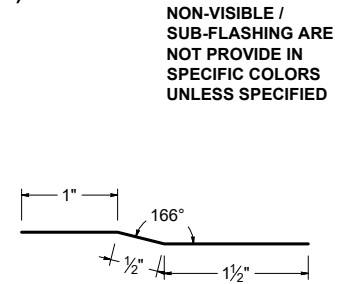

SCALE 1:2 S.O. 3" WEIGHT: 2.5 LBS.

NON-VISIBLE / SUB-FLASHING ARE NOT PROVIDE IN SPECIFIC COLORS UNLESS SPECIFIED

**BOX GUTTER
(CLBG)**

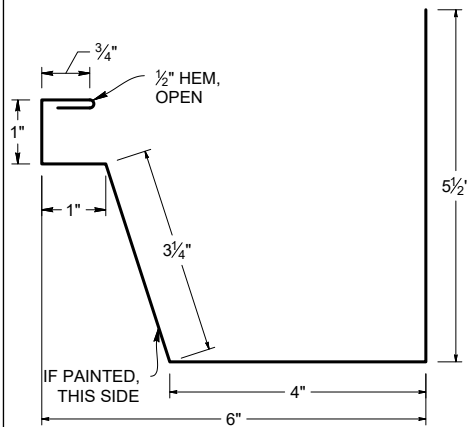

SCALE 1:3 S.O. 16" WEIGHT: 13.3 LBS.

**SUPPORT FLASHING
(CLSF)**

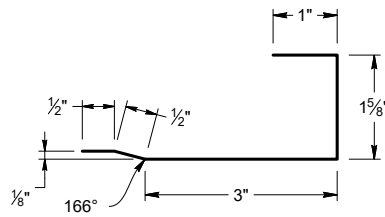

SCALE 1:3 S.O. 6.625" WEIGHT: 6 LBS.

**STANDARD GABLE
(CLGS)**

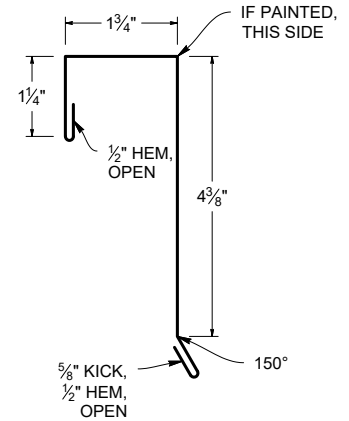

SCALE 1:3 S.O. 9" WEIGHT: 7.6 LBS.

**ALTERNATE GABLE
(CLGA)**

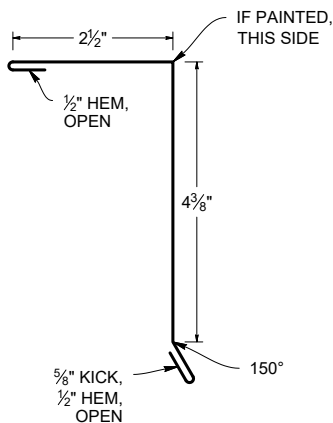

SCALE 1:3 S.O. 8.5" WEIGHT: 7 LBS.

**GABLE CLEAT
(CLGC)**

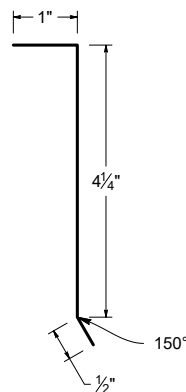

SCALE 1:3 S.O. 5.75" WEIGHT: 4.7 LBS.

**ALTERNATE GABLE L CLOSURE
(CLALC)**

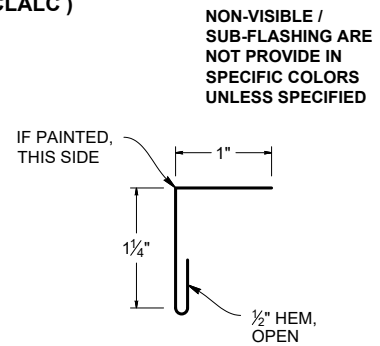

SCALE 1:2 S.O. 2.75" WEIGHT: 2.5 LBS.

STANDARD RIDGE (CLRS)

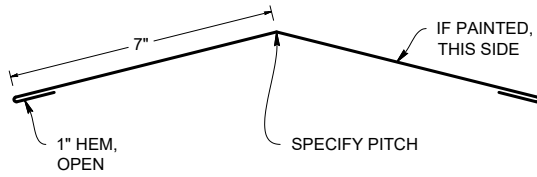

SCALE 1:5 S.O. 16" WEIGHT: 13.1 LBS.

FULL VENTED RIDGE (CLRFB)

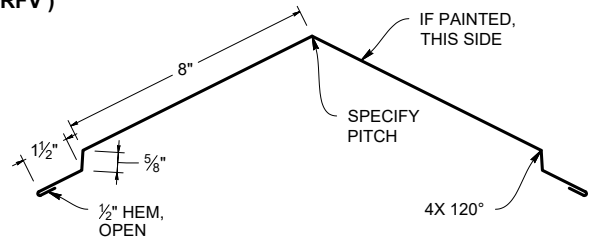

SCALE 1:6 S.O. 21.25" WEIGHT: 17.4 LBS.

VALLEY FLASHING (CLVF)

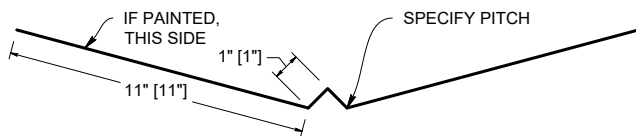

SCALE 1:6 S.O. 24" WEIGHT: 19.7 LBS.

ZEE CLOSURE (CLZC)

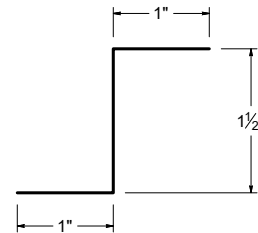

SCALE 1:3 S.O. 3.5" WEIGHT: 3 LBS.

RIDGE END CAP (CLREC)

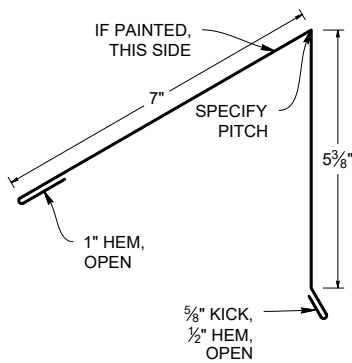

SCALE 1:4 S.O. 14.5" WEIGHT: 11.9 LBS.

VENTED RIDGE END CAP (CLRECV)

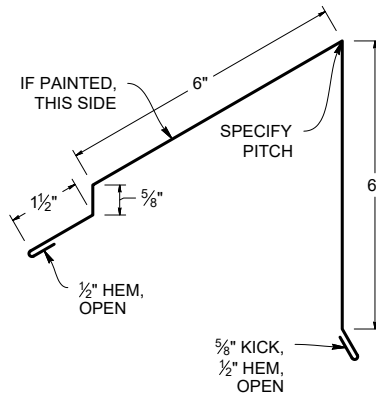

SCALE 1:4 S.O. 15.75" WEIGHT: 12.9 LBS.

RIDGE END CAP CLEAT (CLRECC)

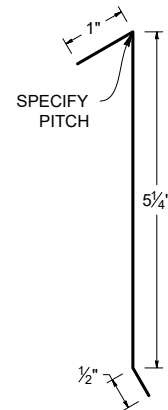

SCALE 1:3 S.O. 6.75" WEIGHT: 6 LBS.

WIDE VALLEY FLASHING (CLVFW)

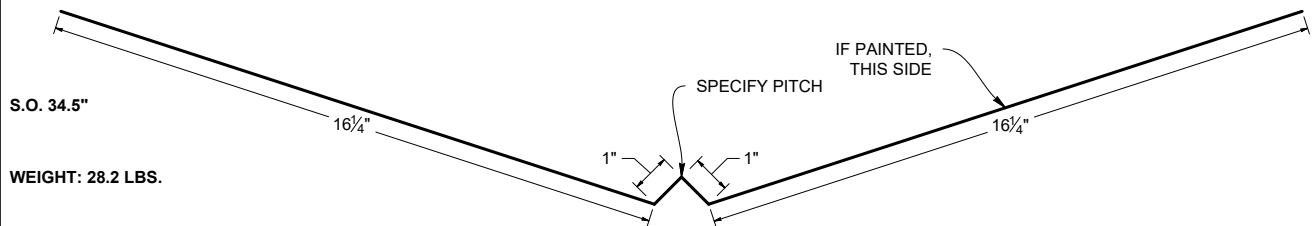

S.O. 34.5"
WEIGHT: 28.2 LBS.

SCALE 1:5

**PAN FLASHING
(CLPAN)**

S.O. 24"

WEIGHT: 21.3 LBS.

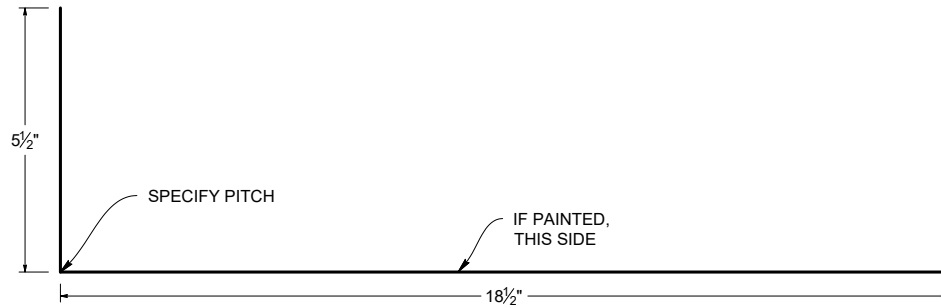

SCALE 1:4

**CURB HEAD
(CLCH)**

SCALE 1:4

S.O. 12"

WEIGHT: 9.8 LBS.

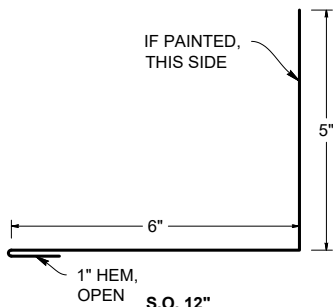

**REGLET
(CLRF)**

SCALE 1:3

S.O. 5.625"

WEIGHT: 4.6 LBS.

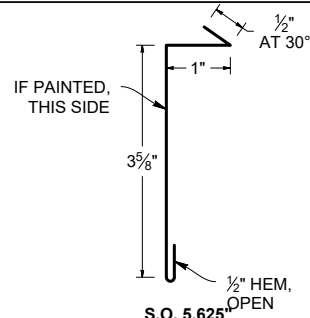

**CURB SIDEWALL
(CLCSW)**

SCALE 1:4

S.O. 9.75"

WEIGHT: 8.2 LBS.

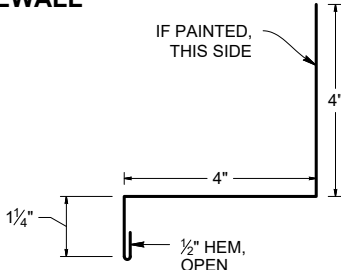

**SIDEWALL
(CLSW)**

SCALE 1:4

S.O. 7.75"

WEIGHT: 6.6 LBS.

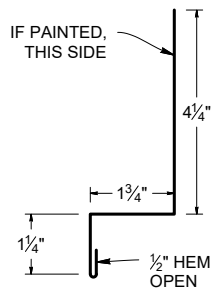

**ENDWALL
(CLEW)**

SCALE 1:4

S.O. 12"

WEIGHT: 9.8 LBS.

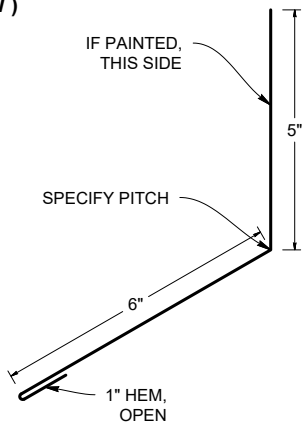

**VENTED ENDWALL
(CLEWV)**

SCALE 1:4

S.O. 12"

WEIGHT: 10.7 LBS.

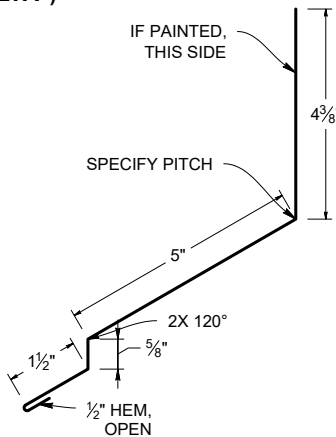

END DAM

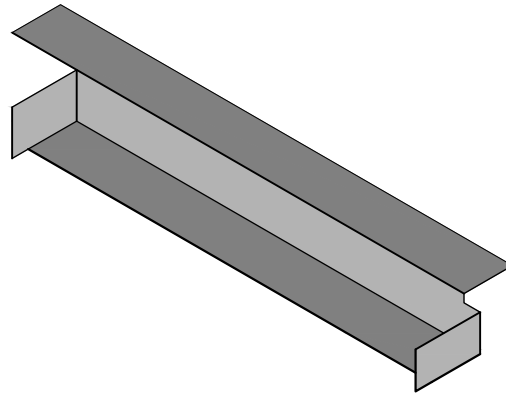

S.O. VARIES

WEIGHT: VARIES

NON-VISIBLE / SUB-FLASHING ARE NOT PROVIDE IN SPECIFIC COLORS UNLESS SPECIFIED

GUTTER HANGER (AGH6)

S.O. 8"

WEIGHT: 0.5 LBS.

SCALE 1:2

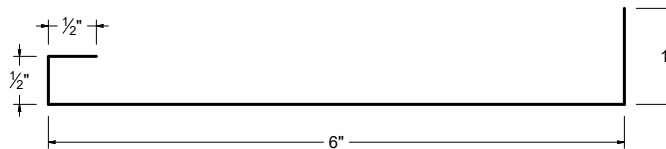

4" PERFORATED STRIP (CLPS)

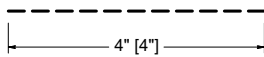

SCALE 1:3

S.O. 4"

WEIGHT: 3.3 LBS.



Custom Trim Order

Customer Name: _____ Job Name: _____

Gauge: _____ Color: _____ Status: Original New

Specify: Angles Color Side Dimensions Stretchout

SO _____

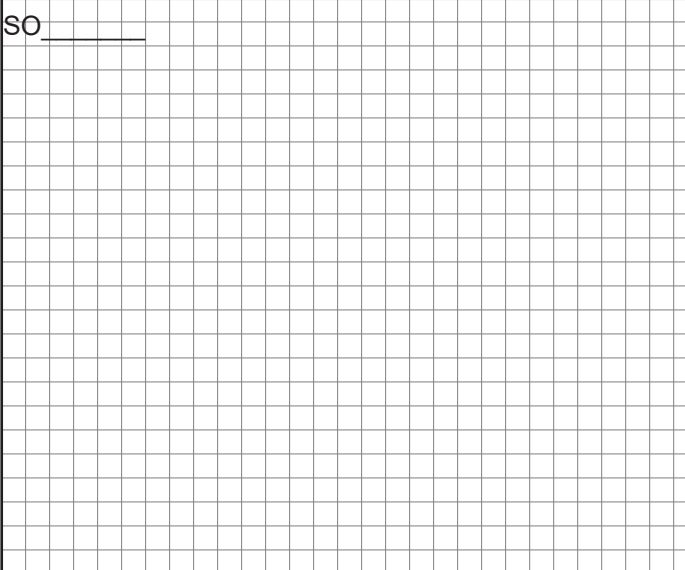

Dwg #: _____ Pitch: _____ # of Pieces: _____

Description: _____

Hems: Open Closed Slightly Open

SO _____

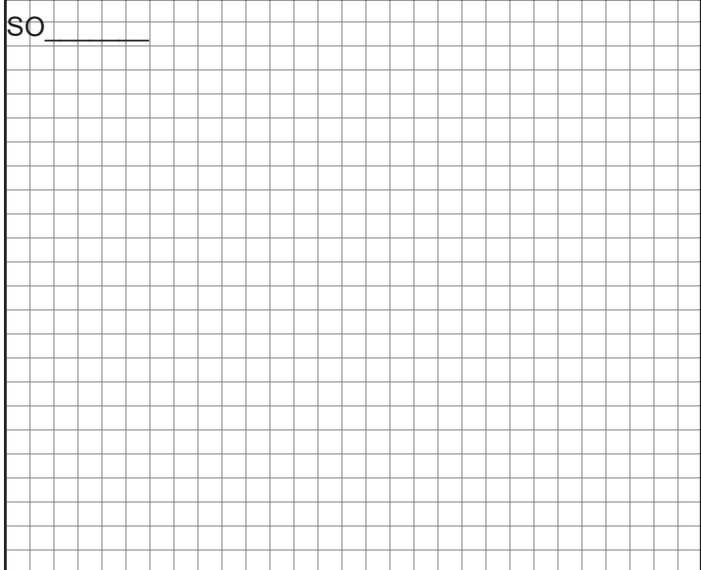

Dwg #: _____ Pitch: _____ # of Pieces: _____

Description: _____

Hems: Open Closed Slightly Open

SO _____

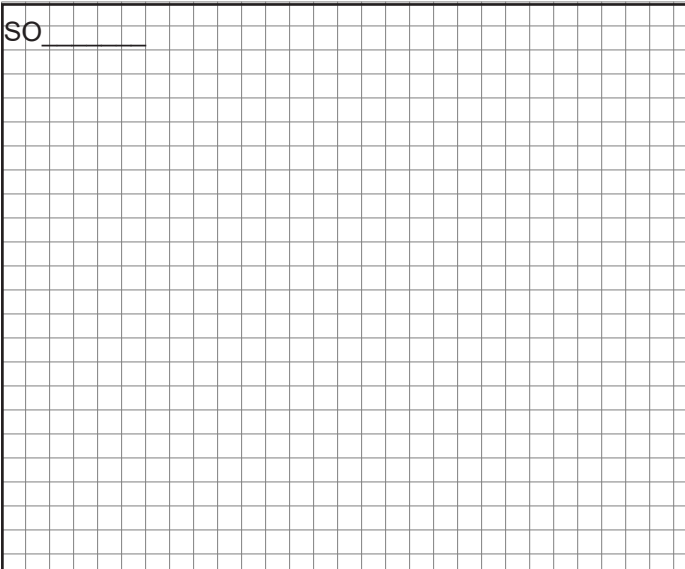

Dwg #: _____ Pitch: _____ # of Pieces: _____

Description: _____

Hems: Open Closed Slightly Open

SO _____

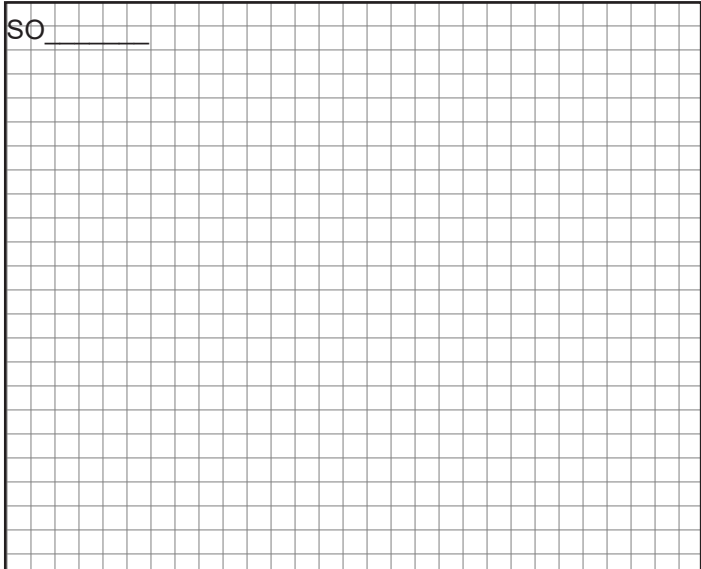

Dwg #: _____ Pitch: _____ # of Pieces: _____

Description: _____

Hems: Open Closed Slightly Open

Please provide a drawing for each flashing with precise measurements and angles

Fax to: 503-581-6877

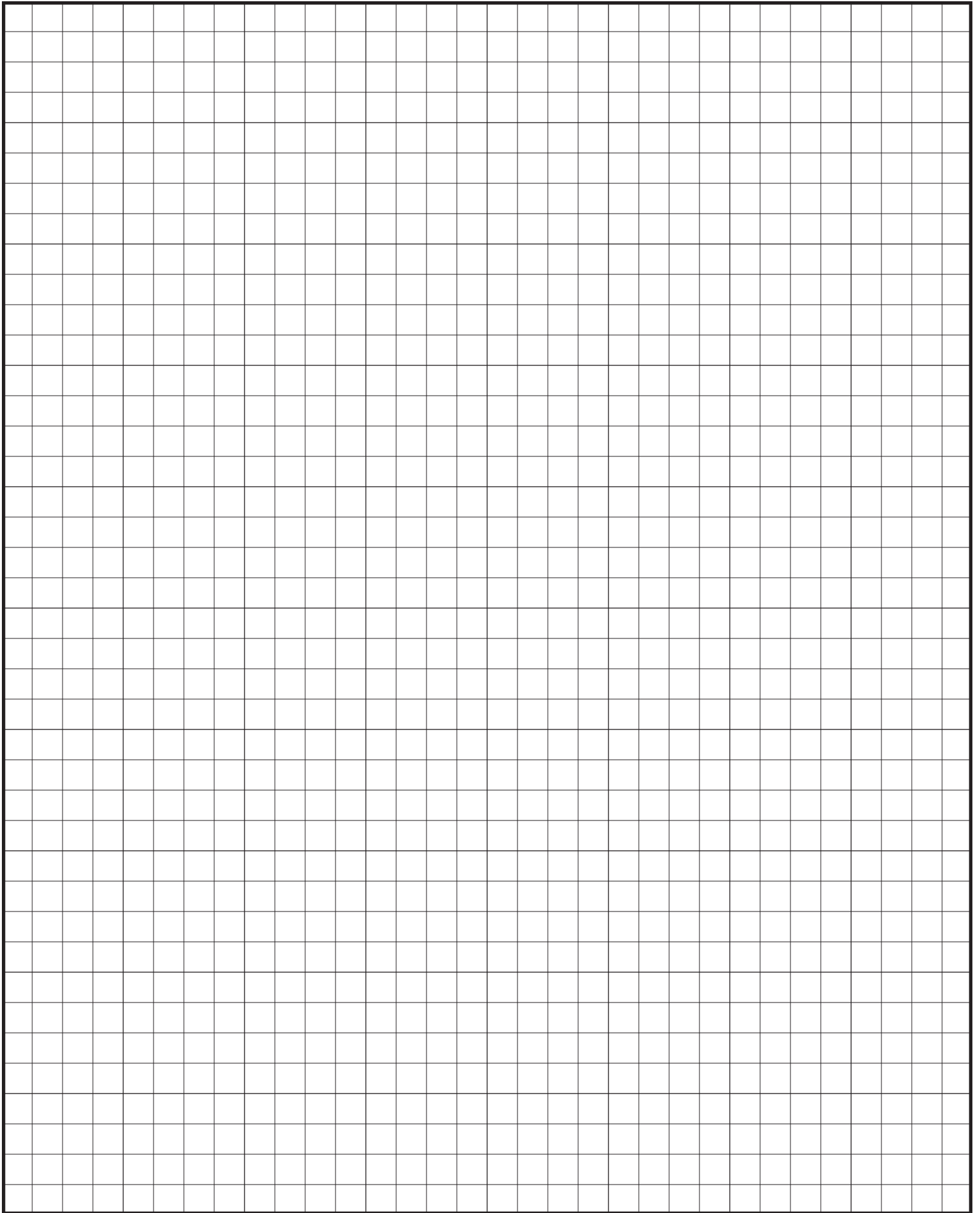

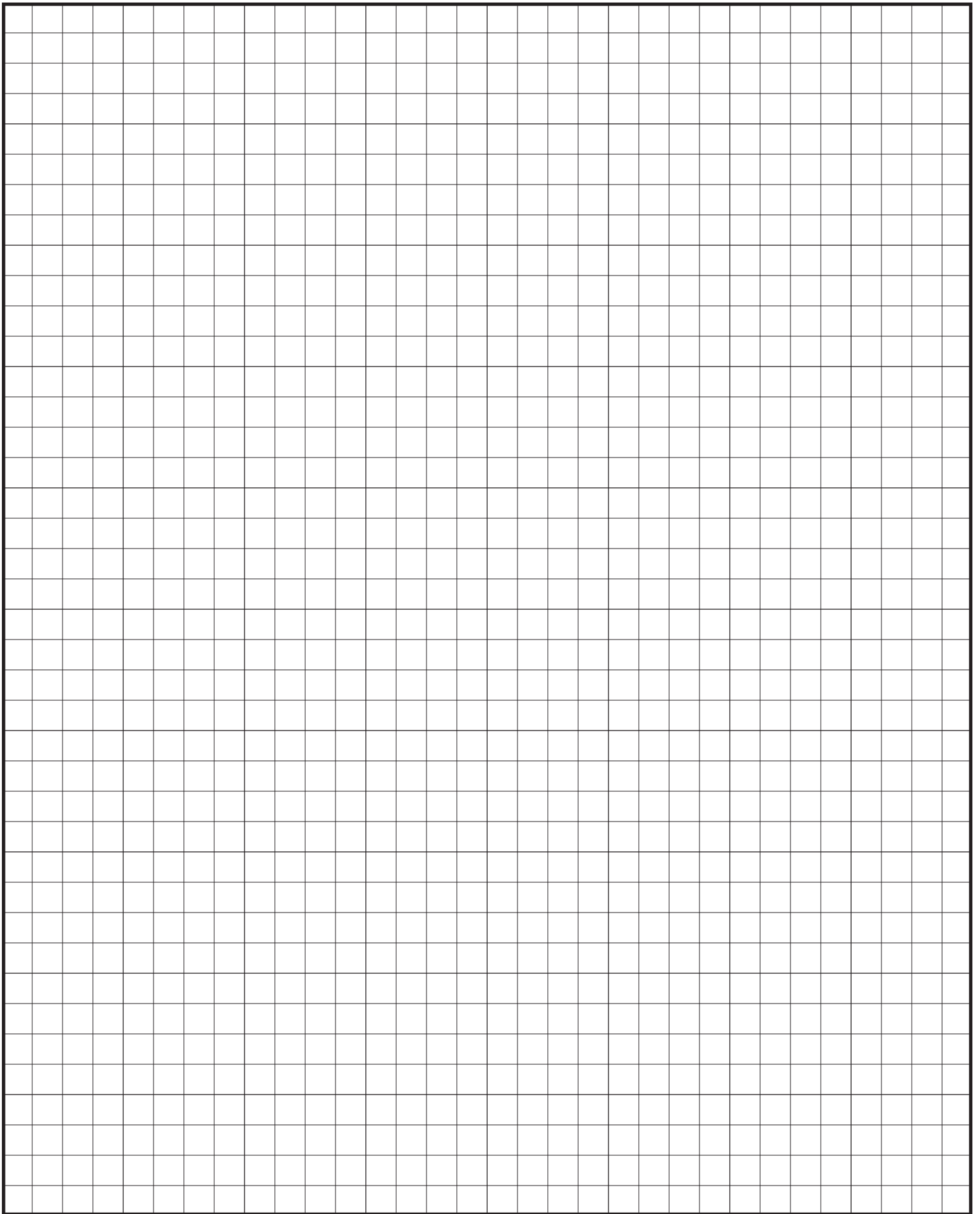



TAYLOR

METAL PRODUCTS

**QUALITY PRODUCTS
EXCEPTIONAL SERVICE**

SALEM BRANCH

4566 Ridge Dr. NE
Salem, OR 97301

Office: 503-581-8338
Toll Free: 1-800-574-1388
Fax: 503-581-6877

SACRAMENTO BRANCH

5711 Perrin Ave
McClellan, CA 95652

Office: 916-318-8844
Toll Free: 1-800-574-1388
Fax: 916-993-4123

SPOKANE BRANCH

1010 N Nelson St.,
Spokane, WA 99202
www.go-rsp.com

Office: 509-535-8667
Toll Free: 800-238-4057
Fax: 509-535-8682

AUBURN BRANCH

2601 C St SW,
Auburn, WA 98001

Office: 206-900-9923
Toll Free: 1-800-574-1388
Fax: 253-804-3545

RIVERSIDE BRANCH

4880 Felspar St.
Riverside, CA 92509

Office: 323-407-7457
Toll Free: 1-877-504-1594