

Contour Installation Guide

Standoff Clip

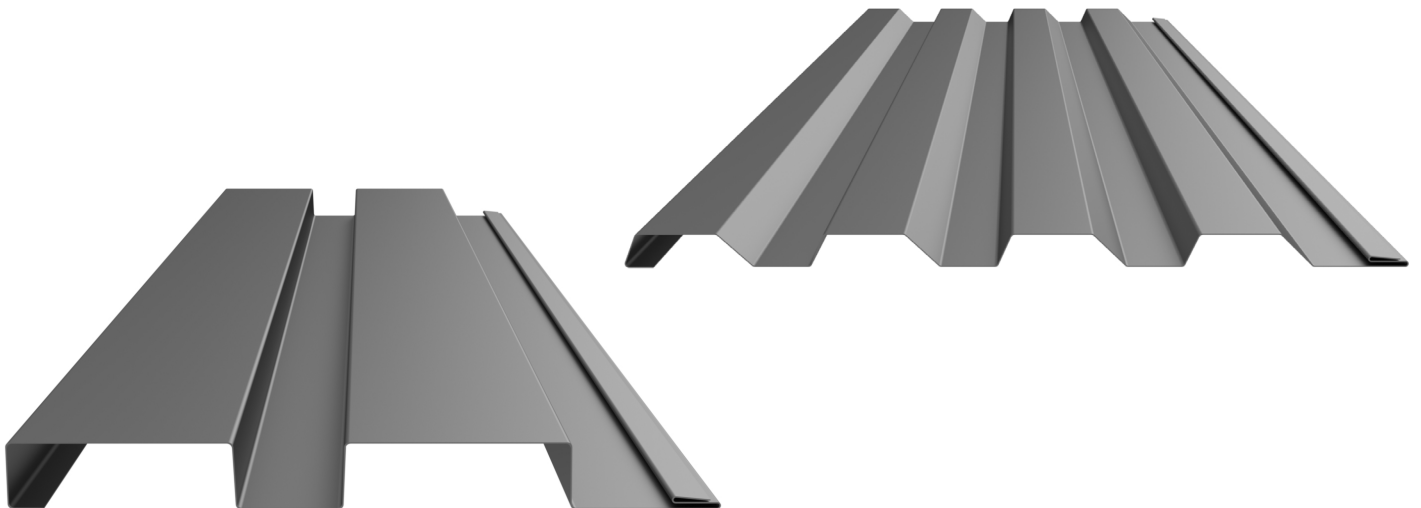

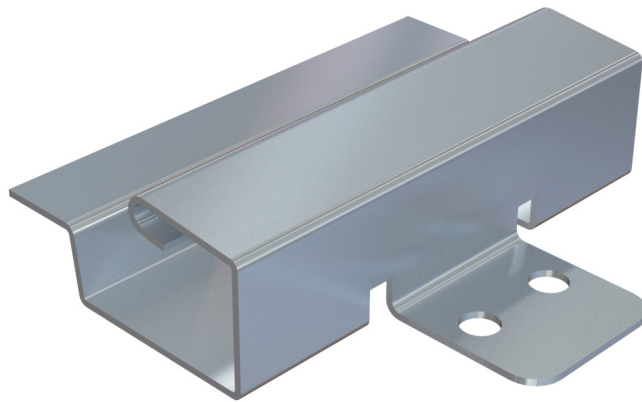
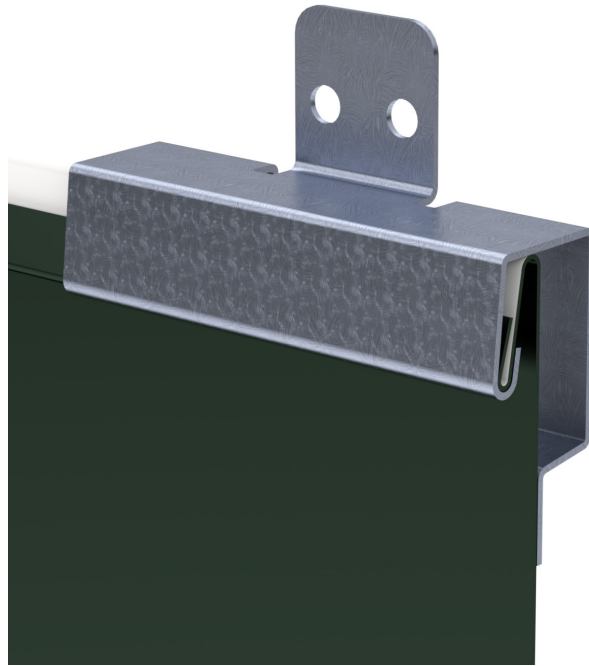

Standoff Clip

Table of Contents

PANEL SPECIFICATION	pg. 1-3
DELIVERY	pg. 4-5
NOTES TO DESIGNER/INSTALLER	pg. 6
HANDLING & STORAGE	pg. 7
PANEL LAP	pg. 8-9
REVEAL LAPS	pg. 10
BASE FLASHING	pg. 11
OUTSIDE CORNER	pg. 12
OUTSIDE CORNER - CONCEALED	pg. 13
INSIDE CORNER	pg. 14
DOOR / WINDOW HEAD	pg. 15
DOOR / WINDOW JAMB	pg. 16
WATER TROUGH	pg. 17
.75" FLASHINGS	pg. 18-21
.875" FLASHINGS	pg. 22-25
1" FLASHINGS	pg. 26-29
1.25" FLASHINGS	pg. 30-33
1.5" FLASHINGS	pg. 34-37



Contour Series™ gives you the custom look you want within your budget. If one of our standard profiles does not match your design requirements, no problem, TMP will fabricate the profile that matches your project needs – not ours. Contact us so we can help fulfill your vision of the perfect look.

KEY FEATURES

- 12" and 16" panel coverage
- 24 and 22 gauge Tru-Gauge™, .032 and .040 Aluminum
- 20 and 18 gauge, .050 and .063 Aluminum available (*please inquire*)
- 4' to 20'6" panel lengths
- ASTM E283, ASTM E331, ASTM E1680, ASTM E1646, ASTM A653, ASTM A792, ASTM B209, ASTM E1592 and ASTM E330* (limited)
- 3/4", 1-1/4" and 1-1/2" deep panels
- Custom profiles available
- Application can be vertical or horizontal
- Acceptable for use as a soffit panel
- Panels are interchangeable
- Clip systems available – flush mount and high performance standoff clip (required for 18 and 20 gauge)
- Manufactured in Riverside CA, Sacramento CA & Salem OR

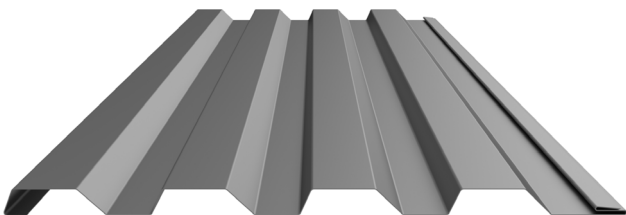

Panel shown is C-1 which is now available in Contour Express Series™

PANEL PROFILES

ES ICC EVALUATION SERVICE™ ICC-ESR #5045 with CBC-CRC Supplement

C-1

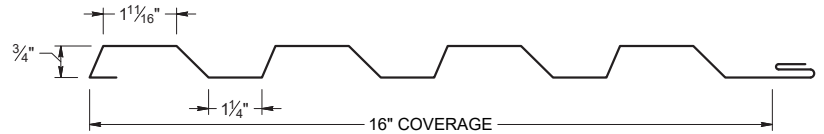

C-2

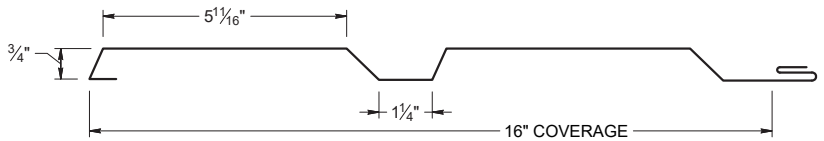

C-3

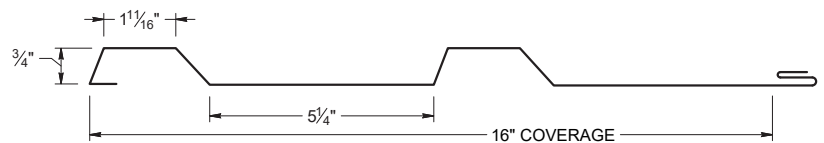

C-4

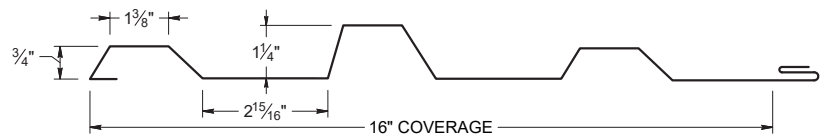

C-5

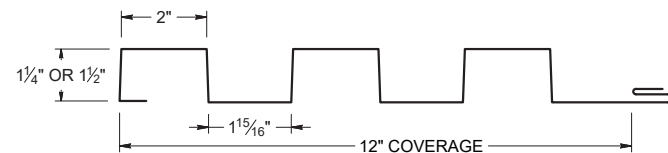

C-6

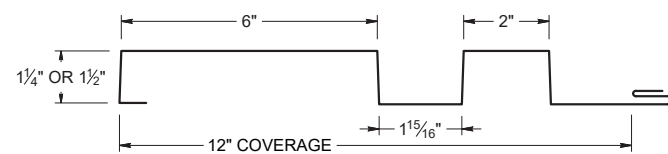

C-7

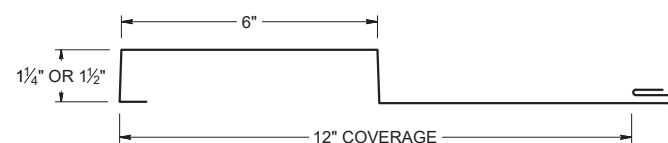

C-8

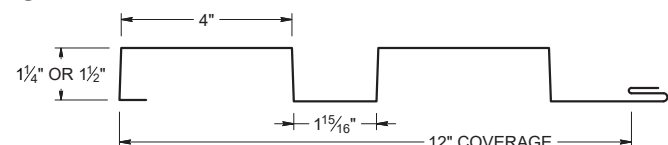



Contour Reveal™ Panels give you various design options for siding and soffit applications. Whether you are looking for clean consistent lines or want to mix and match different profiles, either option will give your building a lifetime of elegance.

KEY FEATURES

- 12" panel coverage
- 24 and 22 gauge Tru-Gauge™
- Custom gauges available: 18-20 gauge
- .032 Aluminum available
- 4' to 20'6" panel lengths
- ASTM E283, ASTM E331, ASTM E1680, ASTM E1646, ASTM E1592, ASTM A653, ASTM A792 and ASTM B209
- 1" and 1-1/2" deep panels
- Custom profiles to match any size of Contour Reveal™: 1" to 6" (custom reveals available)
- Application can be vertical or horizontal
- Acceptable for use as a soffit panel
- Panels are interchangeable
- Clip systems available – flush mount and high performance standoff clip (required for 18-20 gauge)
- Manufactured in Riverside CA, Sacramento CA & Salem OR

PANEL PROFILES

ES ICC EVALUATION SERVICE™ ICC-ESR #5045 with CBC-CRC Supplement

CR-A

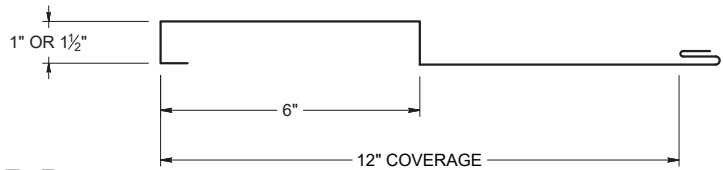
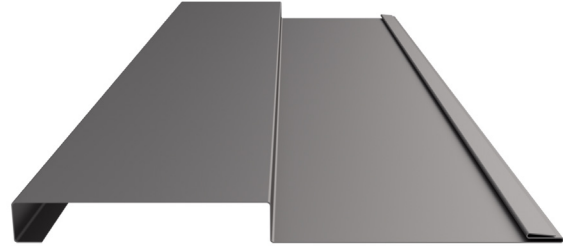

CR-B

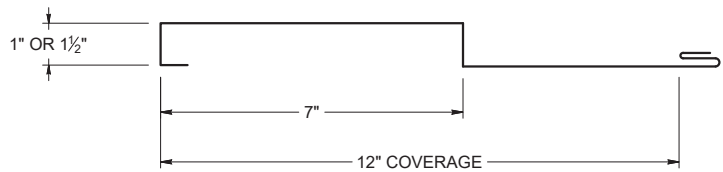

CR-C

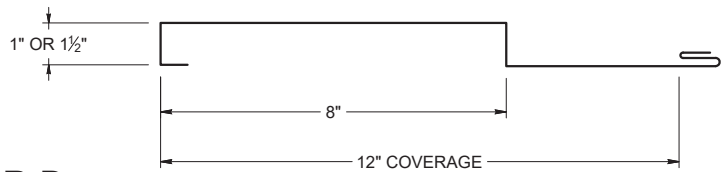

CR-D

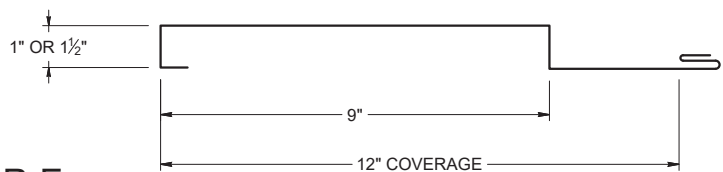

CR-E

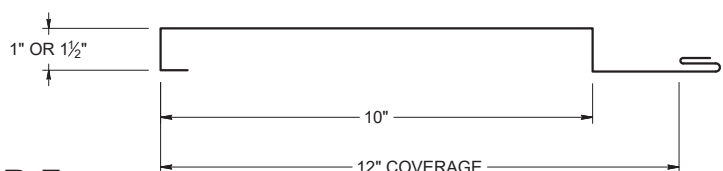

CR-F

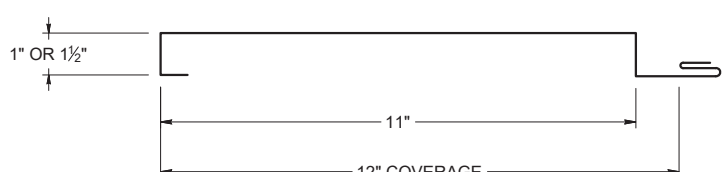

Note: 22 gauge panels require a larger stretch out for the screw flange

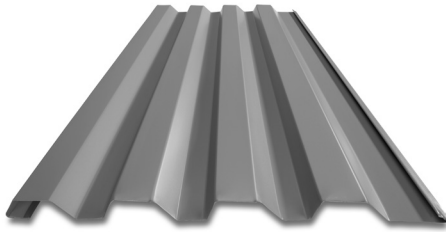

CE-A with Clip Flange

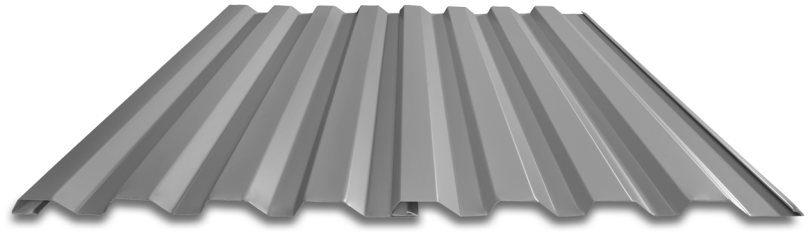

2 CE-A Panels with Clip Flange

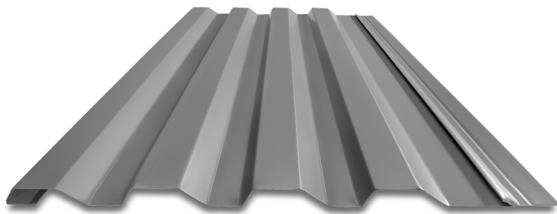

CE-A with Screw Flange

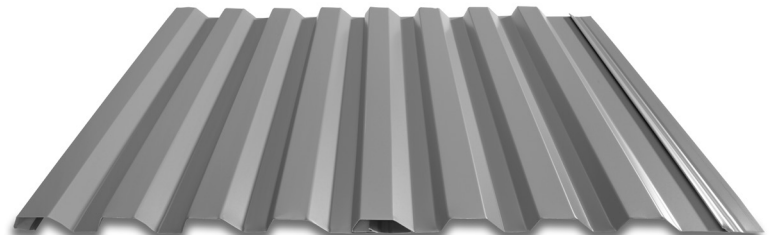

2 CE-A Panels with Screw Flange

ES ICC EVALUATION SERVICE™ ICC-ESR #5045 with CBC-CRC Supplement

KEY FEATURES

- Contour Express Series™ offers faster lead times
- 8", 12" and 16" panel coverage
- 24 and 22 gauge Tru-Gauge™ and .032 Aluminum
- CE-A: 2' to 60' panel lengths
CE-B & CE-E: 2' to 20' panel lengths
- Seamless runs, fewer runs and less labor
- ASTM E283, ASTM E331, ASTM E1680, ASTM E1646, ASTM E1592, ASTM A653, ASTM A792 and ASTM B209
- 7/8" deep panel
- Application can be vertical or horizontal
- Acceptable for use as a soffit panel
- Panels are interchangeable
- Available with screw flange or clip flange
- Clip systems available – flush mount and high performance standoff clip
- Call about Joint Sealant option
- Manufactured in Riverside CA, Sacramento CA & Salem OR

PANEL PROFILES

CE-A

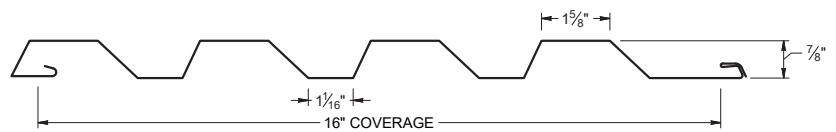

CE-B

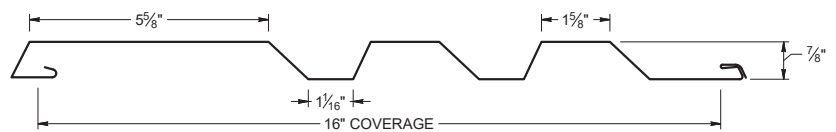

CE-E

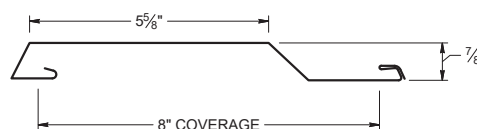

Delivery Fleet

Taylor Metal Products prides itself with quick lead times delivered with our fleet of semi trucks. Our fleet of trucks are owned and operated by TMP. All of our drivers are Taylor Metal Products employees, so when your truck rolls in to deliver, you are dealing with Taylor Metal Products.

Expect constant and exceptional service with short lead times. The inhouse fleet allows for efficient and cost-effective delivery.



Mounted on the rear of a carrier vehicle, the truck-mounted "piggy-back" forklift will accompany you right to your place of use, opening up unprecedented possibilities in terms of transportation. It can travel sideways, carrying panels up to 40' long, allowing delivery in locations that would typically be considered impossible to reach.

Save time and effort while avoiding potential loading and transport issues; have experienced TMP personnel deliver and unload your order.



Delivery & Will Call/Loading



Delivery

We will make every attempt to deliver material to the desired location. We may be unable to gain access on tight corners or steep terrain. If the site is deemed inaccessible by our driver, the customer may choose an alternate delivery site within a reasonable proximity. If we are unable to make the alternate delivery, additional charges may be assessed.

The customer is responsible for:

- Determining adequate access for delivery ahead of time.
- Meeting the delivery at the agreed upon time.
- Providing adequate resources (1-4 people as needed) for off loading materials.
- **A charge of \$100 per hour may be added for deliveries that go beyond their allotted time**
- Check the shipment at the time of delivery.
- Verify material quantities against the shipping/packing list.
- Note any damage or discrepancies upon the paper work at the time of delivery and notify Taylor Metal Products within 48 hours of delivery.

Delivery times are usually scheduled one day in advance. Taylor Metal Products will make every effort to make the delivery at the scheduled time. Please be aware that there may be conditions beyond our control such as traffic, mechanical failures, road closures, etc. which may affect our schedule.

Will Call/Loading

Flatbed trailers and trucks are best suited to transport metal roofing materials. These can be loaded from the side with a forklift and tied down in a safe and secure manner.

We are not able to load materials onto vehicles and/or trailers which are not suitable or may be hazardous to load. Please be aware that if we find a vehicle to be inappropriate, we reserve the right to refuse to load your order.

Unacceptable examples include: boat trailers, vans, buses, motor homes, campers and box trailers. Pickup racks which do not have sufficient supports for the weight or are not long enough to support bundles are also unacceptable.

Taylor Metal Products is **not** responsible to tie down loads nor do we provide any tie down materials. Please bring tie downs to secure your load (string or twine are **not** acceptable for this purpose).

Consider having your order delivered on one of our trucks with a piggy back forklift.



Notes to Designer/Installer

Taylor Commercial Products is providing the following details as an aid in design. The details in this guide are not inclusive to all design situations. The designer /installer is responsible for modifications and should take into consideration all aspects of the project including climate conditions, such as, snow and wind, as well as, building code requirements, building design, building usage and maintenance requirements.

Installation should be performed only by qualified installers familiar with metal siding systems and industry standards. For details not shown in this guide, refer to the Sheet Metal and Air Conditioning Contractors National Association (SMACNA) architectural sheet metal manual for proper design.

The Standard gauge for all products in this guide is 24 gauge and the standard finish is Kynar 500®/Hylar 5000®. We recommend specifying all flashings be the same gauge, color, and finish as the panels to insure long-term durability and color match.

Substrates

Details in the manual are all shown over solid substrate. Contour can be used over spaced purlins no greater than 24” apart.

For solid substrate, Taylor Commercial Products recommends 5/8” plywood.

Underlayments

Follow manufactures instructions carefully for all underlayment installation.

Oil Canning

Flat metal surfaces will display waviness commonly referred to as “oil canning”. Oil canning is caused by a variety of conditions. Steel mill tolerances, variations in or uneven substrates.

Oil canning is a characteristic of metal siding, not a defect and is not a cause for rejection.

Thermal Movement

The panels and the flashings must be allowed to expand and contract, especially with longer length panels. The panel may need to have a slight gap where the panel hooks the offset cleat to allow for thermal movement of the panels.

Handling / Storage & Safety

Handle materials with care when off-loading or moving materials to avoid damage to panels or flashings. Long panels may require two or more pick-up points, properly spaced to avoid damaging panels. Plan ahead; contact Taylor Commercial Products for recommendations on handling/hoisting long panels. Store the panels, flashings and accessories in a dry, well ventilated area, off the ground. If covering, allow ventilation around panels. Elevate one end of bundle to allow drainage of wet materials.

Take care when painting to avoid getting over spray on the siding material. Remember that wind can carry paint particles some distance. Over spray can cause the finish of the roofing material to look dull and may void your warranty.

Secure materials, especially when leaving the site, on the ground or roof to prevent winds from moving the materials. Wind-blown materials may cause damage to the material, property or persons.

Always use proper safety equipment and attire to minimize risk of cuts or other injuries.

Avoid installing metal panels in windy conditions.

Safety considerations are the responsibility of the installer and his crew. Be sure to use common sense and generally accepted safety practices when installing roofing material.

Panel Lap: C-1 Panel Shown

Relief cuts are required for proper fit

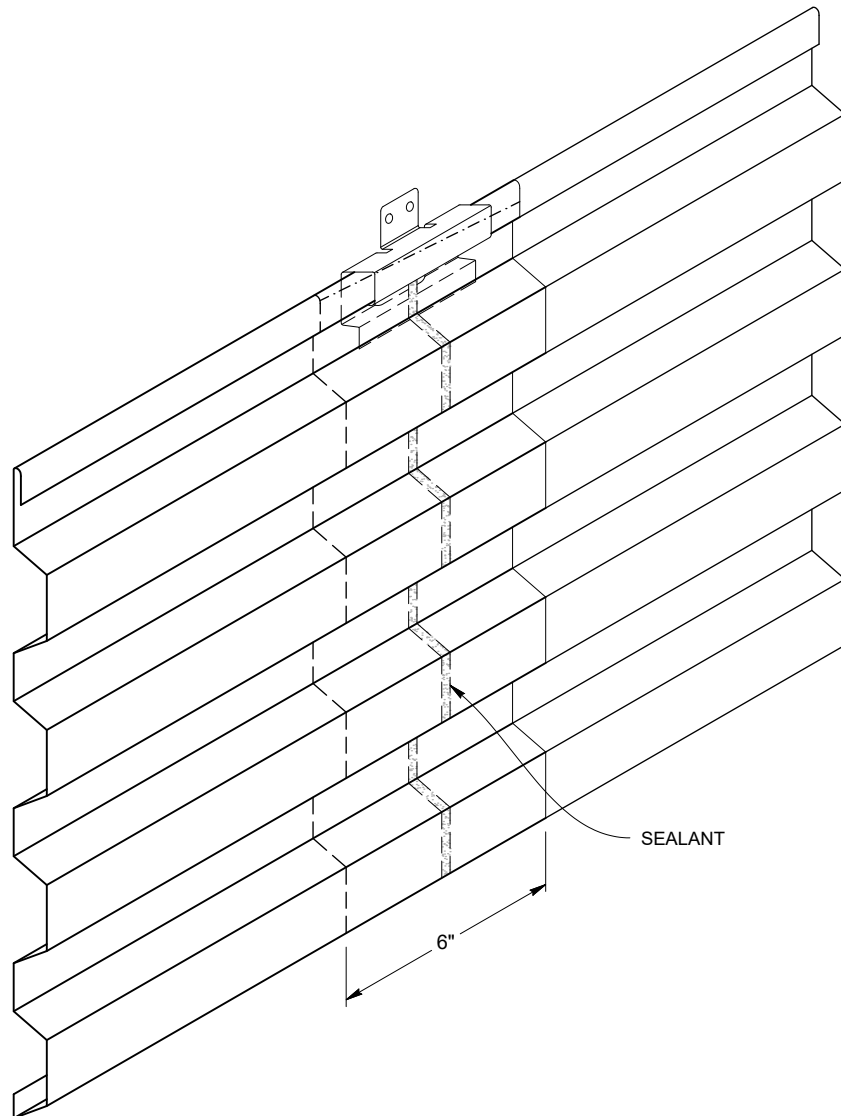

Panel Lap 2: C-1 Panel Shown

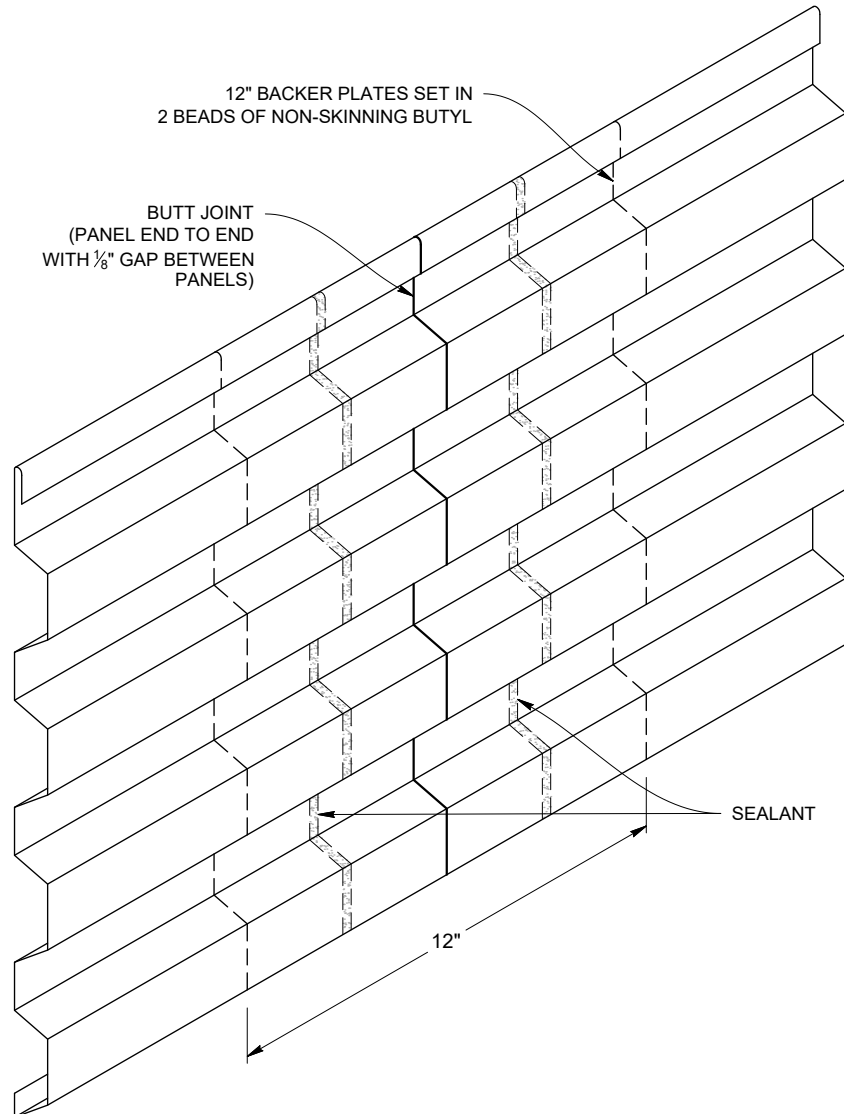

SUPPORT FLASHING CAP DETAIL

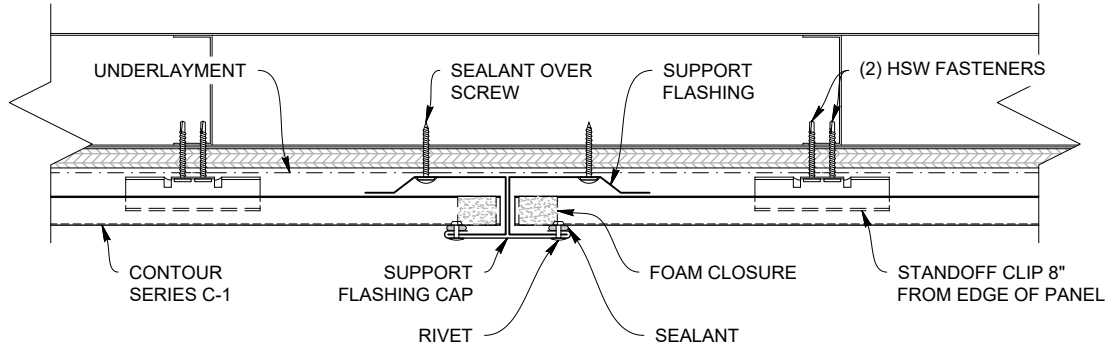

NARROW REVEAL SPLICE DETAIL

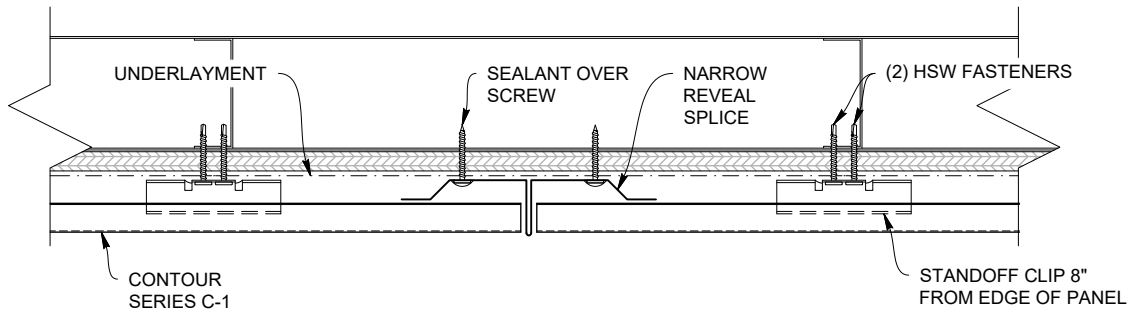

OFFSET J-TRIM DETAIL

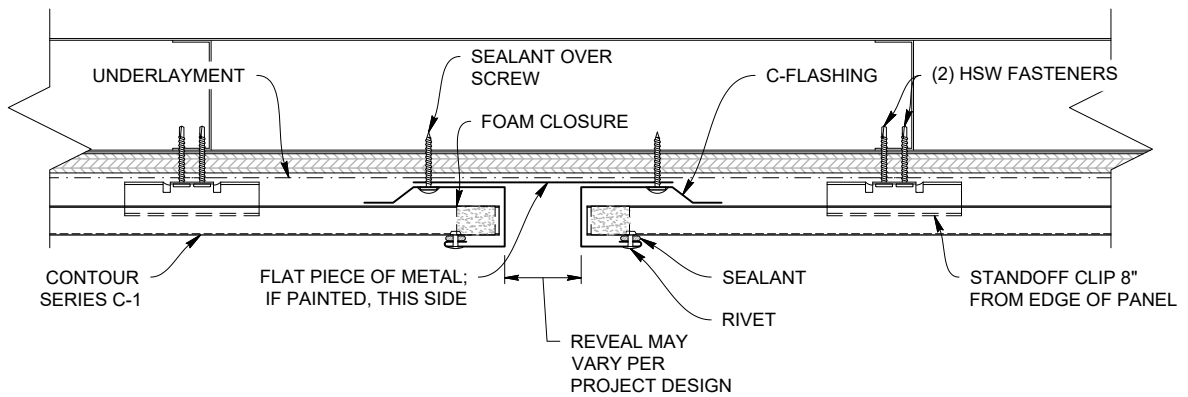

Base Flashing

BASE FLASHING DETAIL: HORIZONTAL

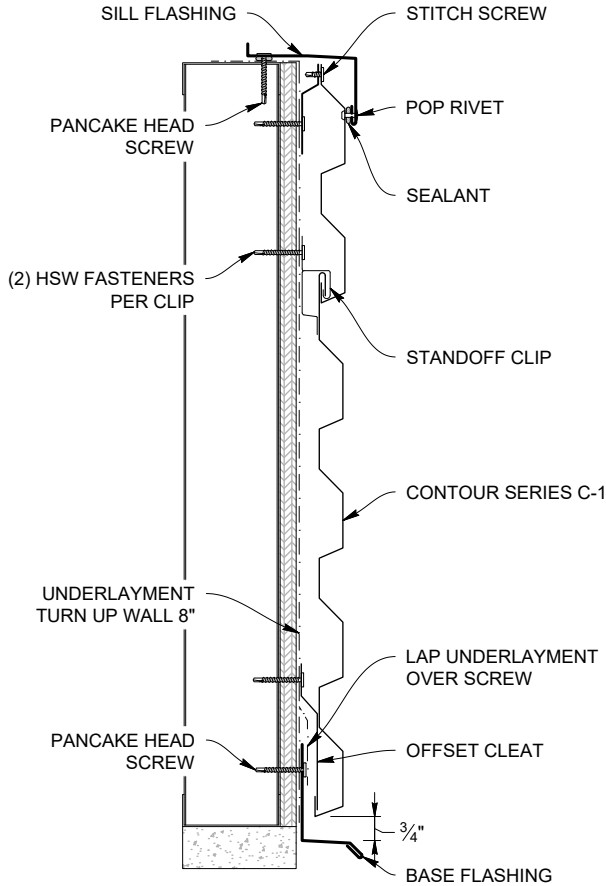

PART SHOWN: BASE FLASHING

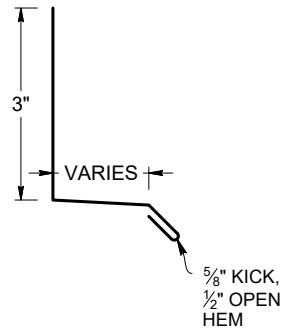

PART SHOWN: SILL FLASHING

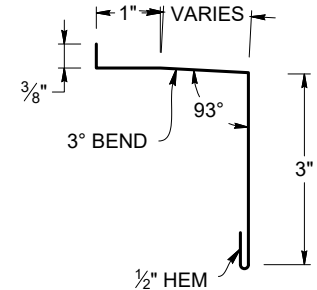

PART SHOWN: CONTOUR OFFSET CLEAT

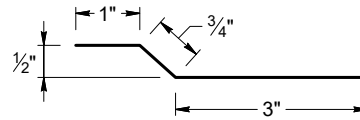

Offset cleat may be perforated to allow ventilation or moisture to escape

BASE FLASHING DETAIL: VERTICAL

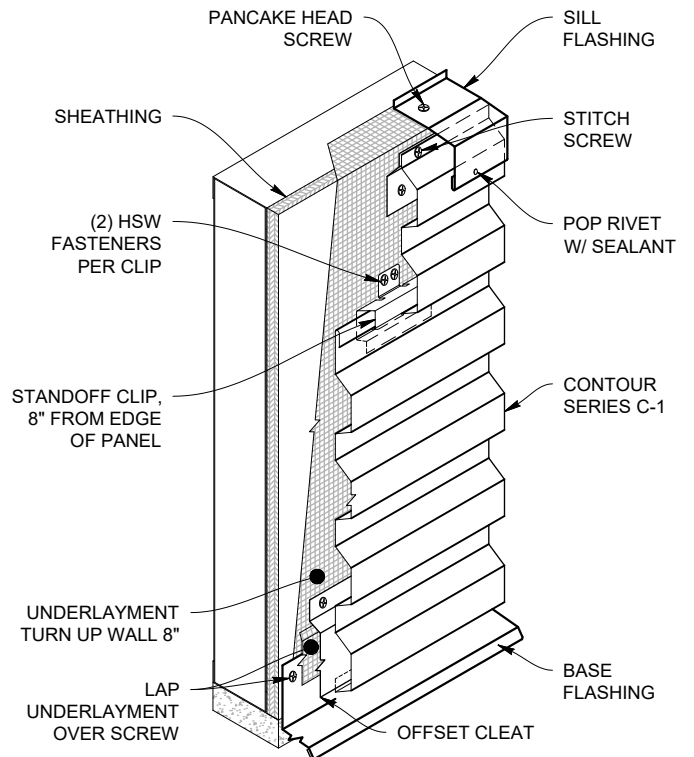
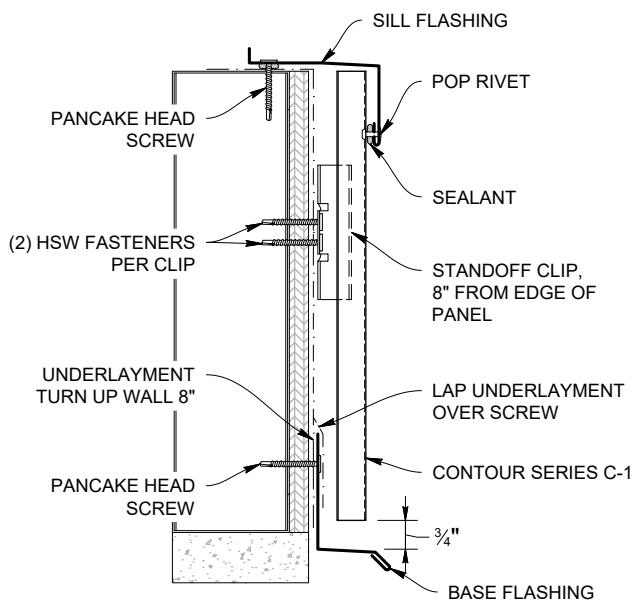

OUTSIDE CORNER DETAIL VERTICAL PANELS

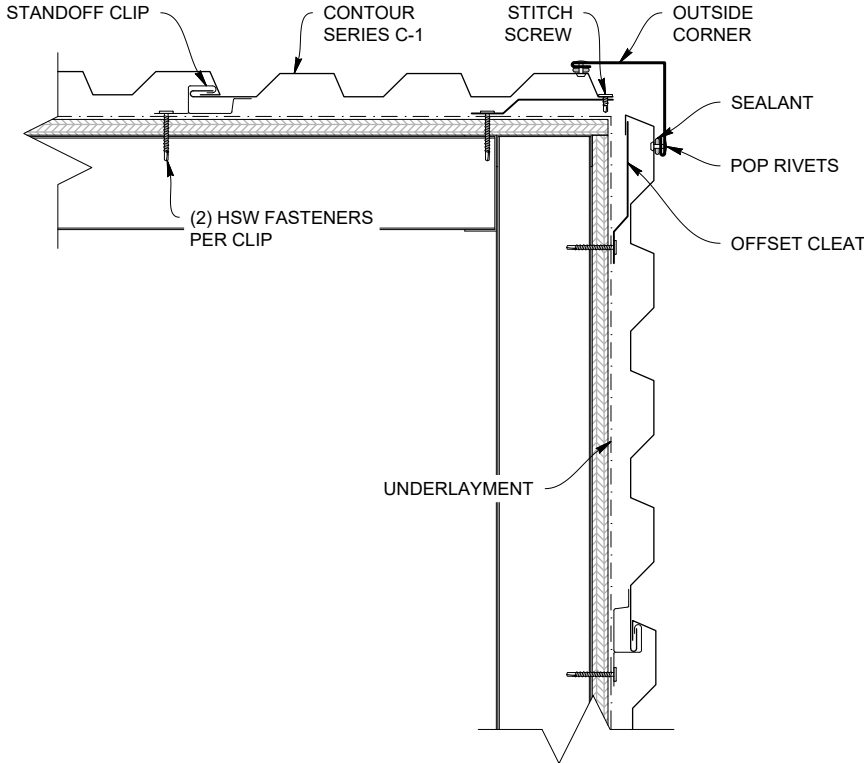

PART SHOWN: OUTSIDE CORNER

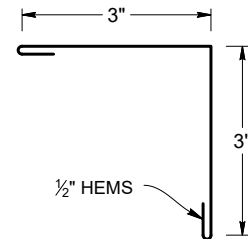

PART SHOWN: CONTOUR OFFSET CLEAT

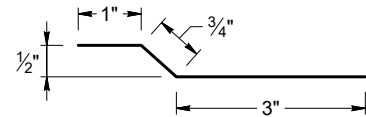

OUTSIDE CORNER DETAIL HORIZONTAL PANELS

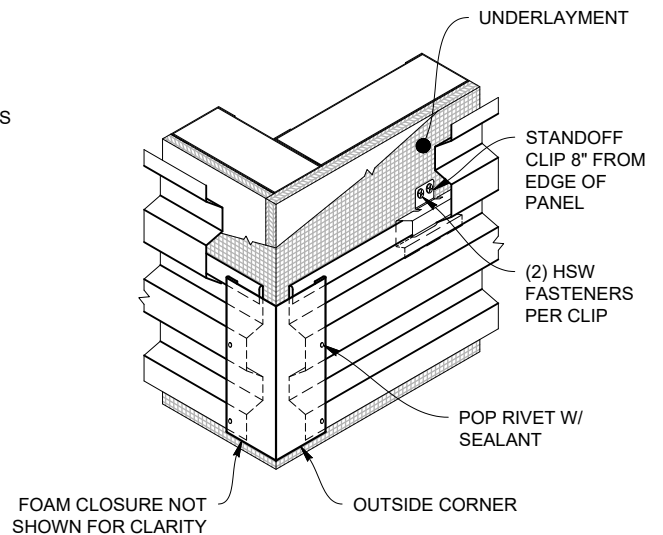
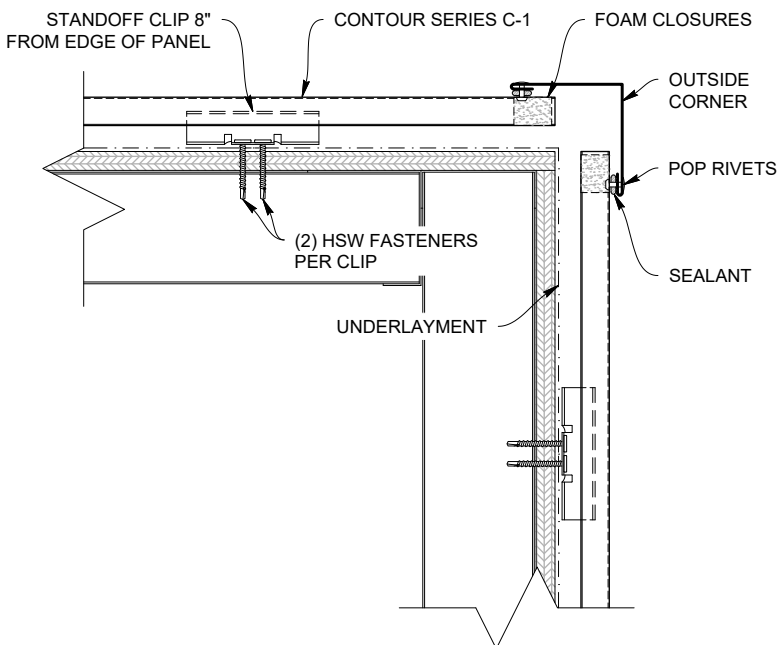

Outside Corner

CONCEALED OUTSIDE CORNER DETAIL VERTICAL PANELS

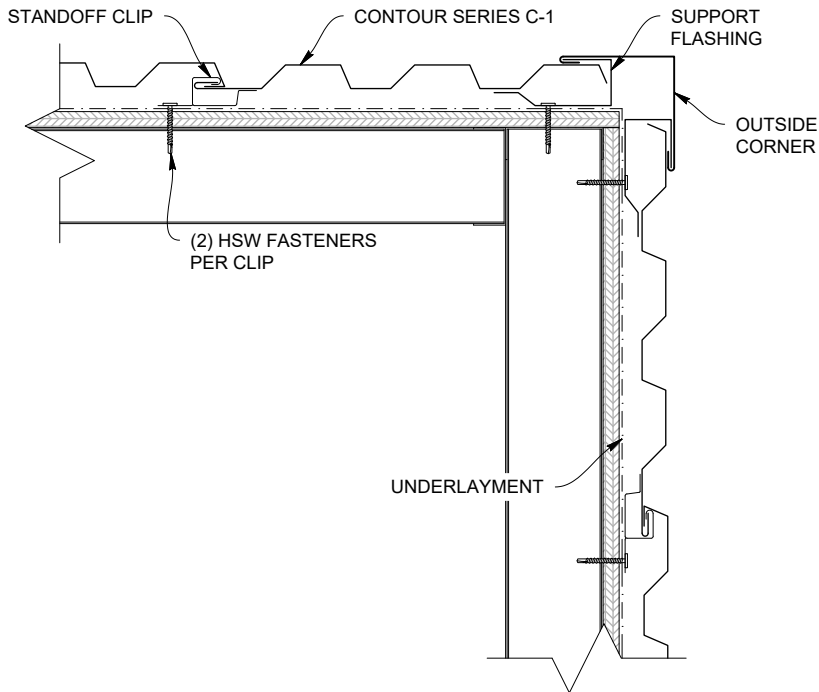

PART SHOWN: OUTSIDE CORNER

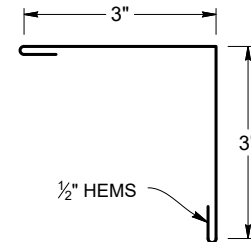

PART SHOWN: SUPPORT FLASHING

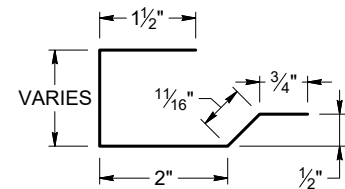

CONCEALED OUTSIDE CORNER DETAIL HORIZONTAL PANELS

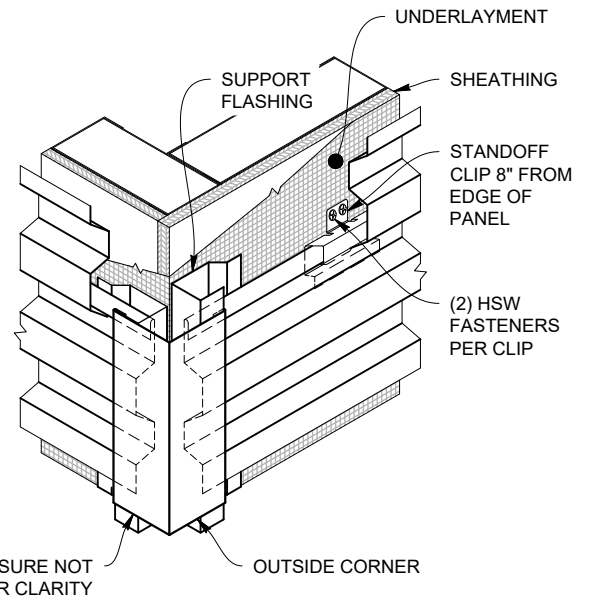
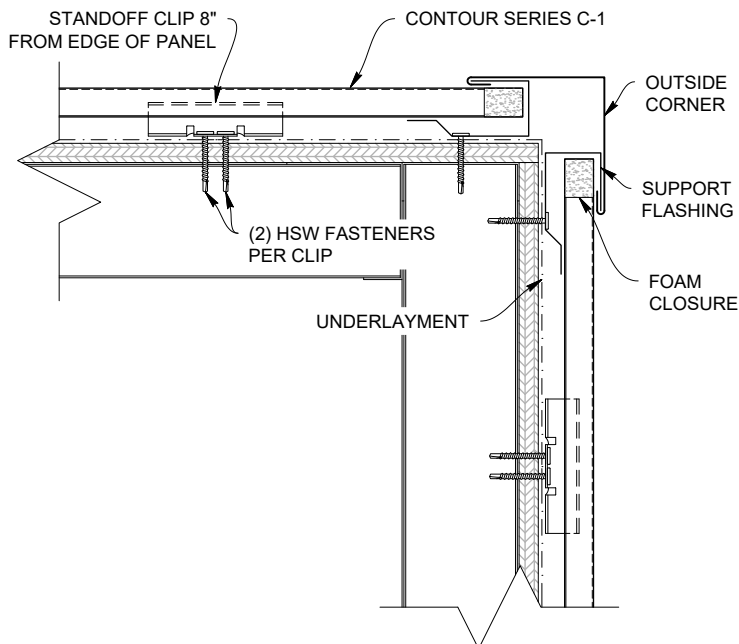

FOAM CLOSURE NOT SHOWN FOR CLARITY

INSIDE CORNER DETAIL VERTICAL PANELS

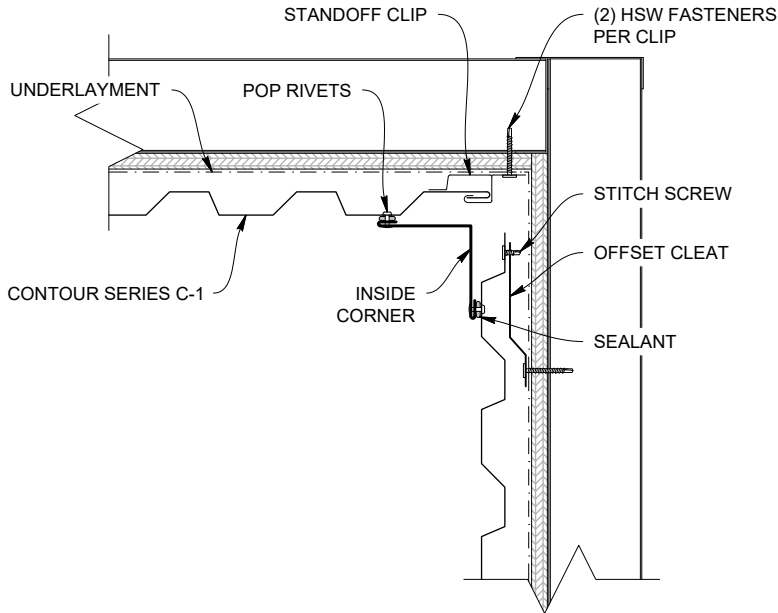

PART SHOWN: INSIDE CORNER

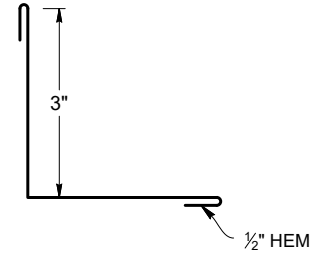

PART SHOWN: CONTOUR OFFSET CLEAT

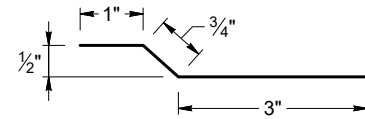

INSIDE CORNER DETAIL HORIZONTAL PANELS

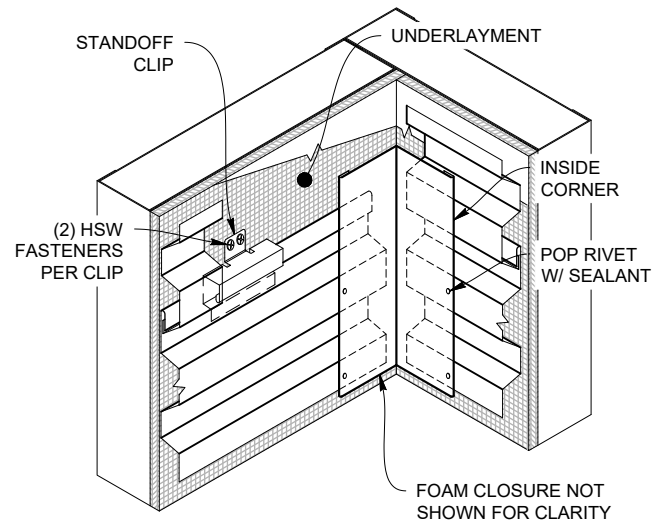
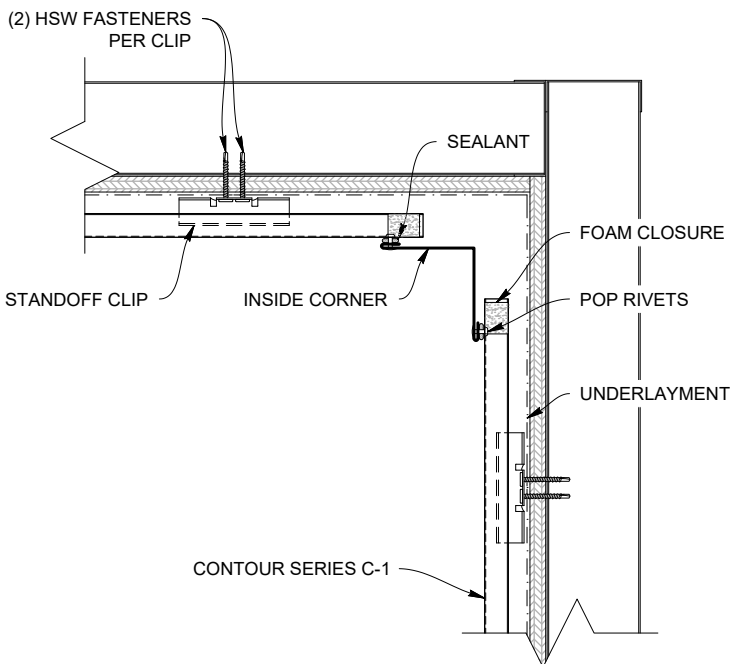

DOOR/WINDOW HEAD DETAIL: HORIZONTAL PANEL

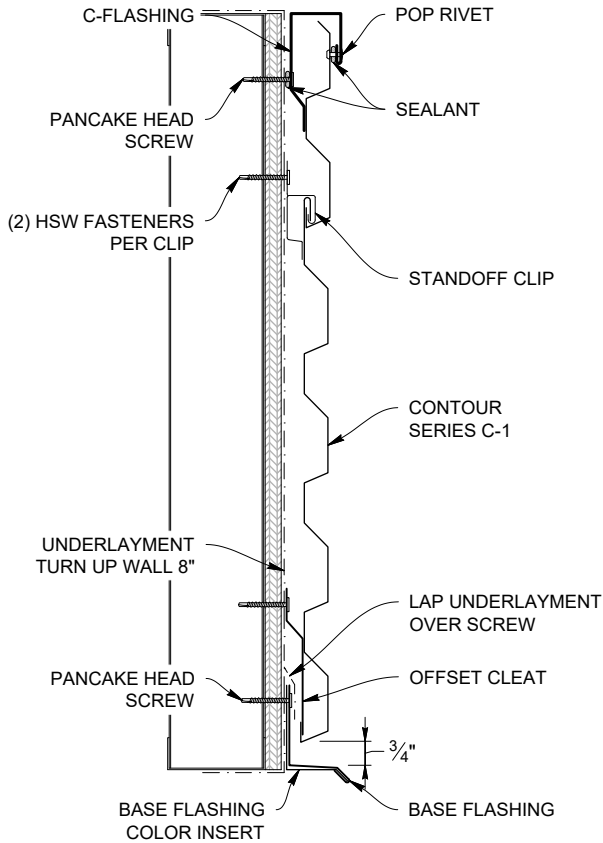

PART SHOWN: BASE FLASHING

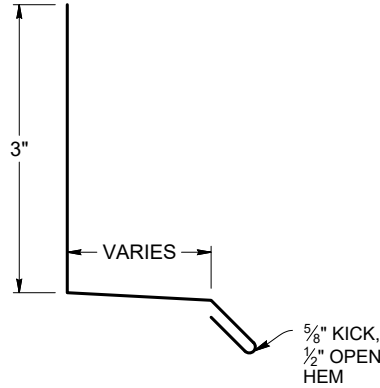

PART SHOWN: BASE FLASHING COLOR INSERT

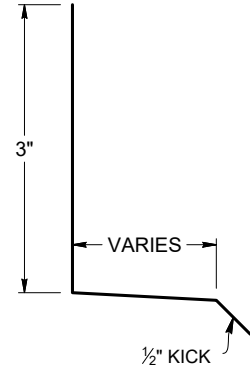

PART SHOWN: CONTOUR C-FLASHING

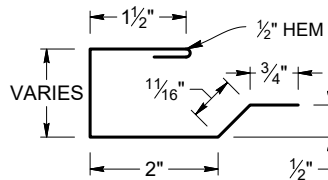

PART SHOWN: CONTOUR OFFSET CLEAT

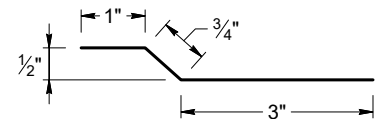

DOOR/WINDOW HEAD DETAIL: VERTICAL PANEL

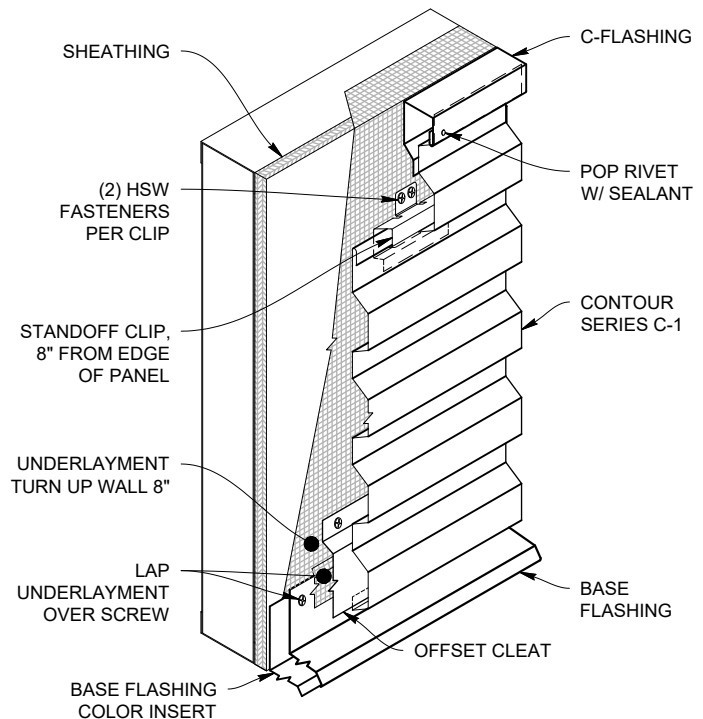
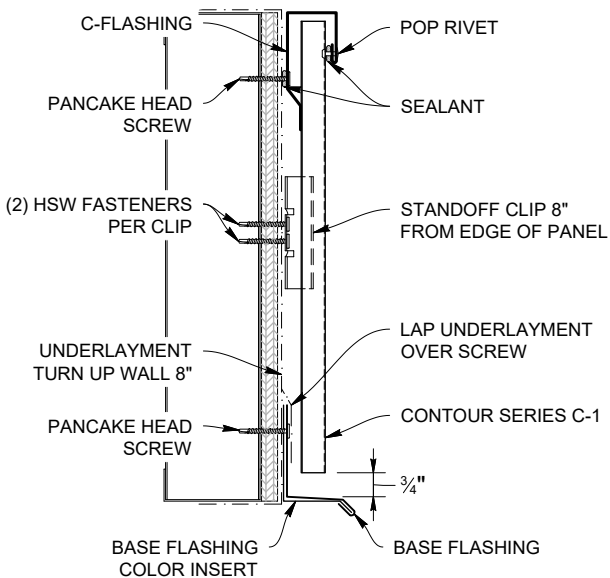

**DOOR/WINDOW JAMB DETAIL:
VERTICAL PANEL**

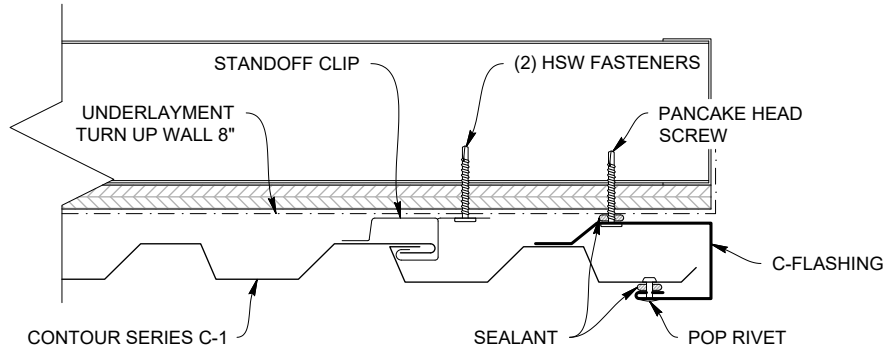

**DOOR/WINDOW JAMB DETAIL:
HORIZONTAL PANEL**

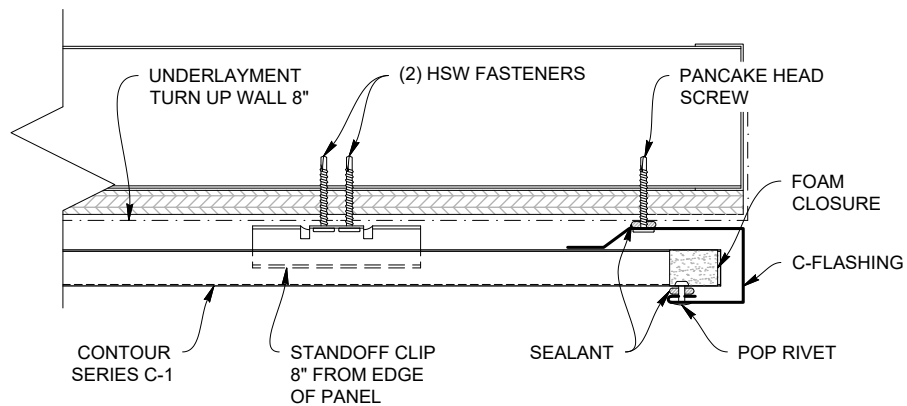

**PART SHOWN: CONTOUR
C-FLASHING**

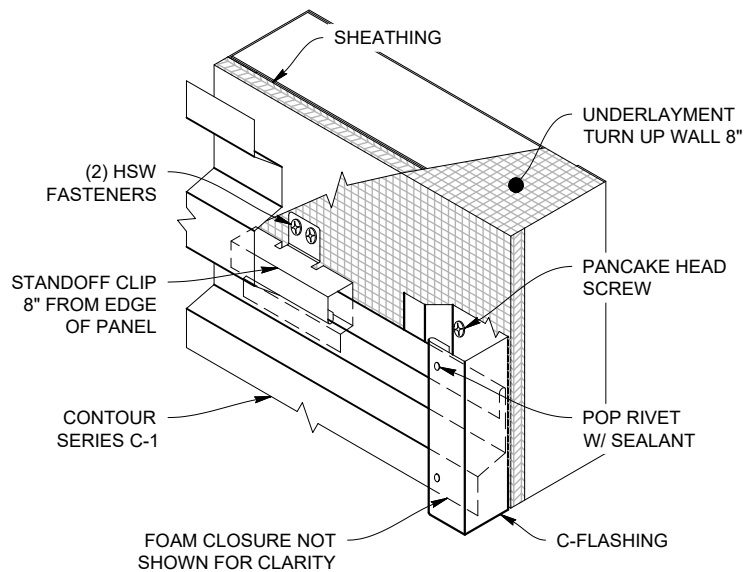
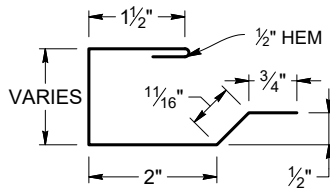

DOOR/WINDOW JAMB DETAIL: VERTICAL

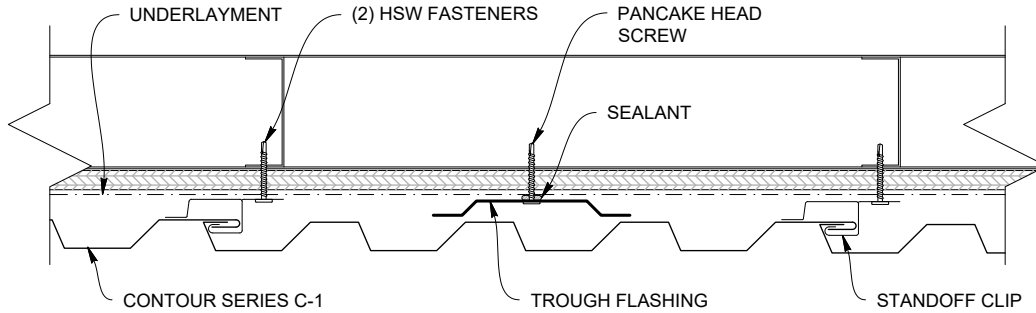

PART SHOWN: TROUGH FLASHING

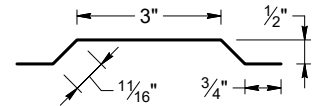

DOOR/WINDOW JAMB DETAIL: HORIZONTAL

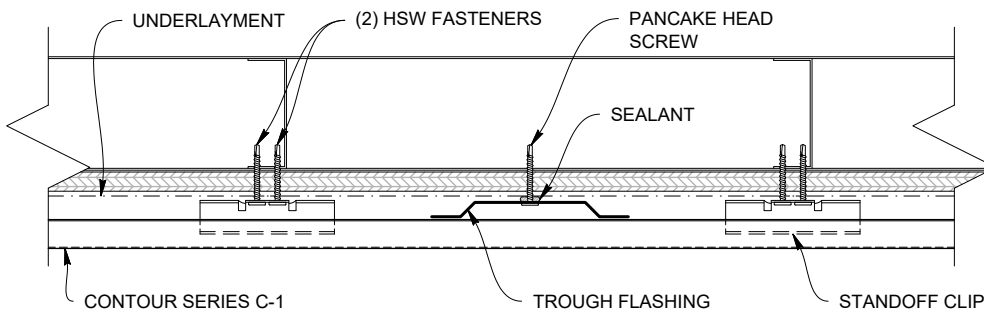

PART SHOWN: SILL FLASHING

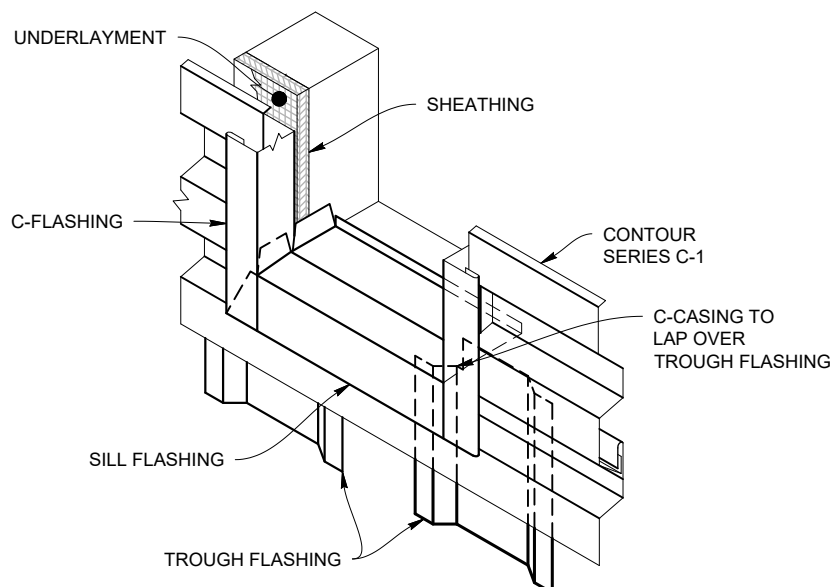
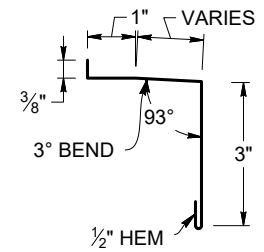

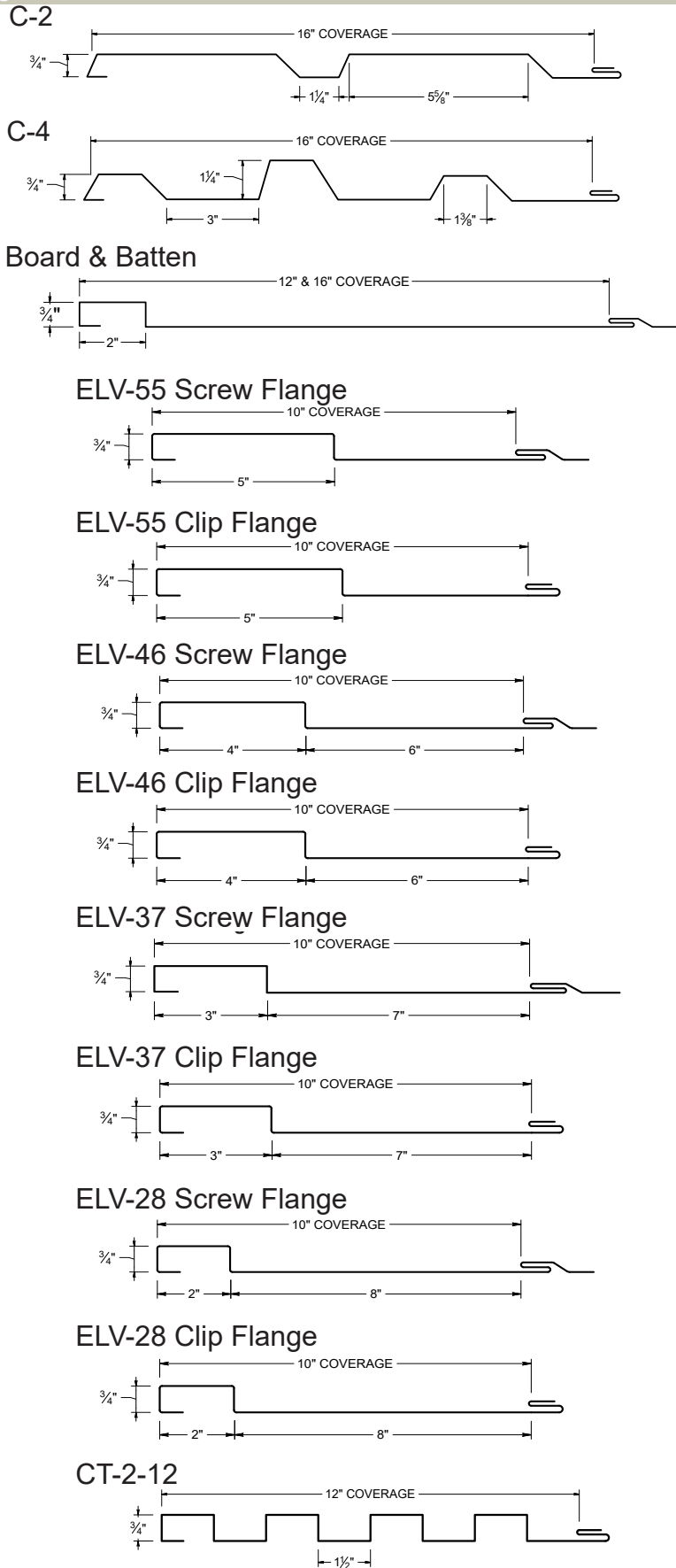

Contour Flashings - .75" Height

Flashing and Details Selection

Flashing: 10' Standard



.75" BASE FLASHING - STANDOFF CLIP
(TKCTBFO075)

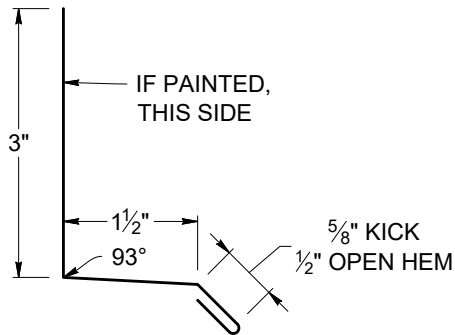

SCALE: 1:2 *WEIGHTS ARE BASED OFF OF 24 GAUGE COILS
S.O. 5.625" WEIGHT: 4.51 LBS

.75" BASE FLASHING COLOR INSERT - STANDOFF CLIP
(TKCTBFI0075)

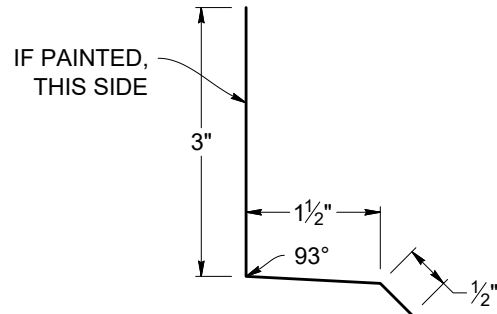

SCALE: 1:2 *WEIGHTS ARE BASED OFF OF 24 GAUGE COILS
S.O. 5" WEIGHT: 4.01 LBS

OUTSIDE CORNER - TYPE A - STANDOFF CLIP
(TKCTCOAS)

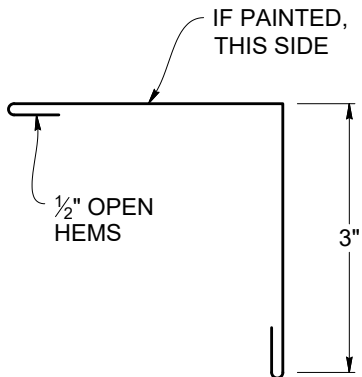

SCALE: 1:2 S.O. 7" WEIGHT: 5.8 LBS.

INSIDE CORNER - TYPE A - STANDOFF CLIP
(TKCTCIAS)

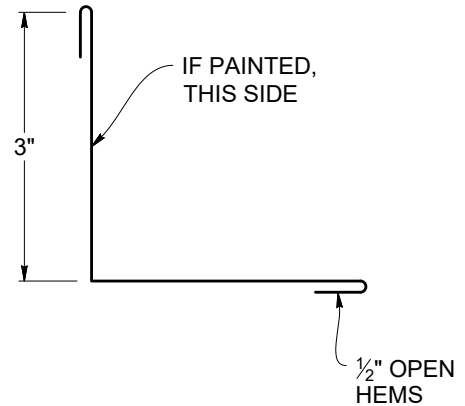

SCALE: 1:2 S.O. 7" WEIGHT: 5.8 LBS.

SUPPORT FLASHING CAP - STANDOFF CLIP
(TK CTSFCS)

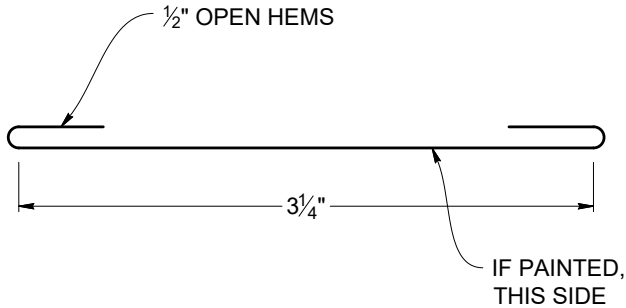

SCALE: 1:1 S.O. 4.25" WEIGHT: 3.35 LBS.

.75" NARROW REVEAL SPLICE - STANDOFF CLIP
(TKCTNRS0075)

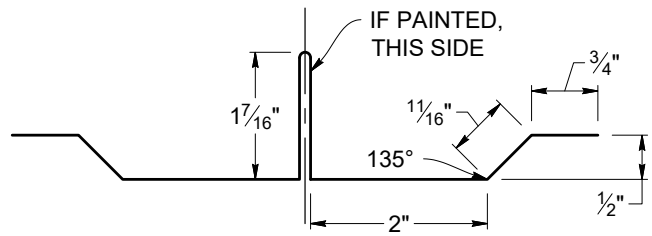

SCALE: 1:2 *WEIGHTS ARE BASED OFF OF 24 GAUGE COILS
S.O. 9.75" WEIGHT: 7.93 LBS.

.75" C-FLASHING - STANDOFF CLIP
(TKCTCF0075)

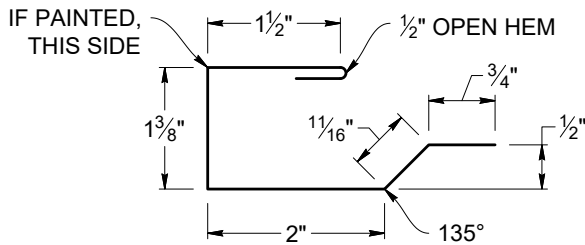

SCALE: 1:2 *WEIGHTS ARE BASED OFF OF 24 GAUGE COILS
S.O. 6.8125" WEIGHT: 5.47 LBS

.75" SUPPORT FLASHING - STANDOFF CLIP
(TKCTSFO075)

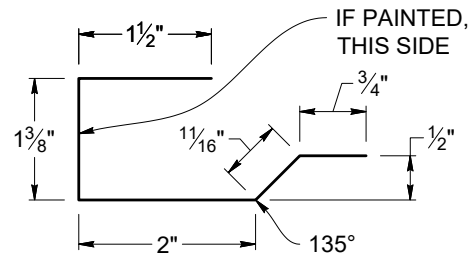

SCALE: 1:2 *WEIGHTS ARE BASED OFF OF 24 GAUGE COILS
S.O. 6.3125" WEIGHT: 5.07 LBS

Contour Flashings - .75" Height

Flashing and Details Selection

Flashing: 10' Standard



TROUGH FLASHING - STANDOFF CLIP
(TKCTTFS)

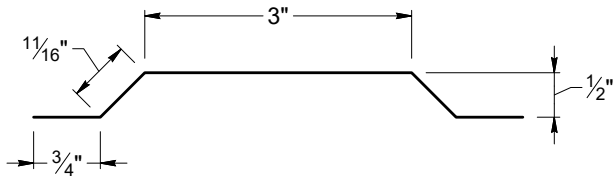

SCALE: 1:2

S.O. 5.875"

WEIGHT: 4.81 LBS.

.75" SILL FLASHING - STANDOFF CLIP
(TKCTFS0075)

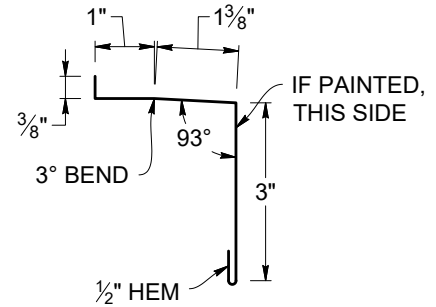

SCALE: 1:3

*WEIGHTS ARE BASED OFF OF 24 GAUGE COILS
S.O. 6.25"

WEIGHT: 5.01 LBS

OFFSET CLEAT - STANDOFF CLIP
(TKCTOCOS)

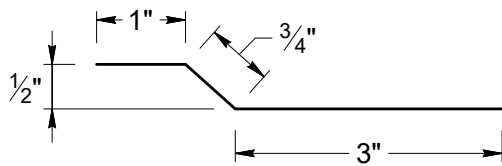

SCALE: 1:2

S.O. 4.75"

WEIGHT: 3.35 LBS.

C1 & CE-A

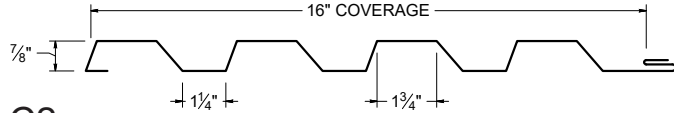

C2

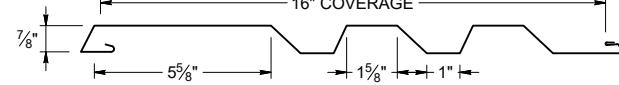

C1-A

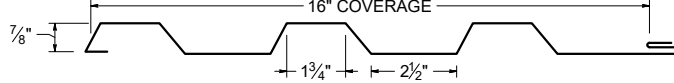

C1-B

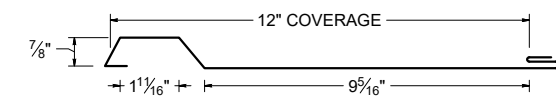

C1-D

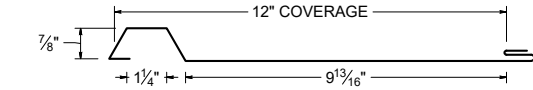

C2-A

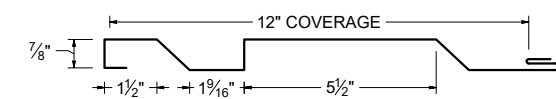

C2-B

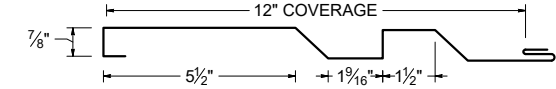

C2-C

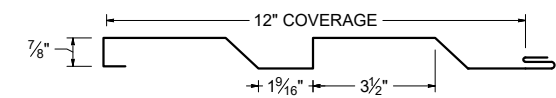

C2-D

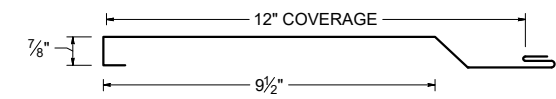

C2-E

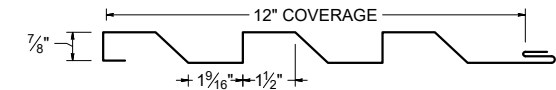

C5-A

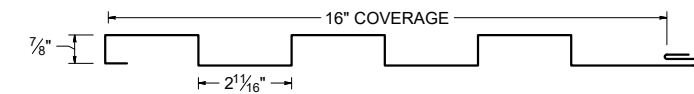

C6-A



CE-B

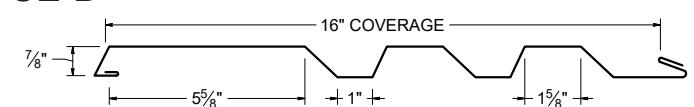

CE-C

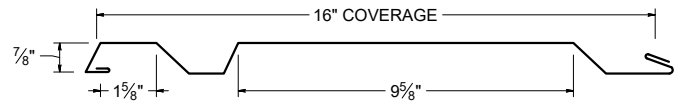

CE-D

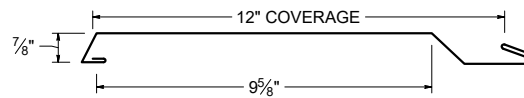

CE-E

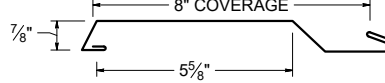

CI-3-12

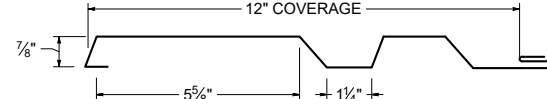

CI-3-16

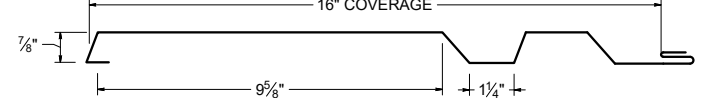

CI-4-12

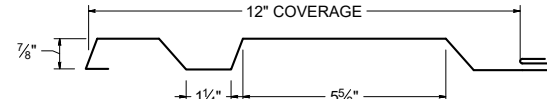

CI-4-16

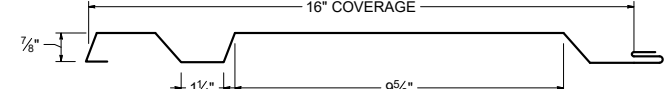

CI-5-12

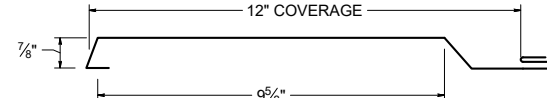

CI-7-12

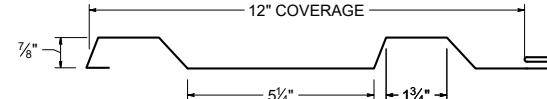

CI-7-16

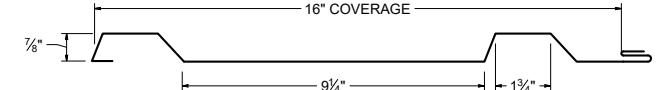

CI-8-12



CI-9-12

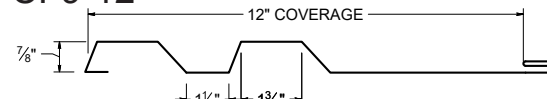

CI-9-16

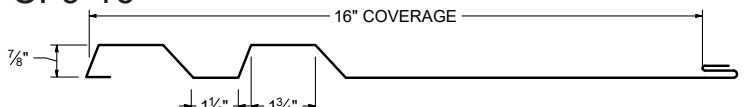

Contour Flashings - .875" Height

Flashing and Details Selection

Flashing: 10' Standard



.875" BASE FLASHING - STANDOFF CLIP
(TKCTBFO875)

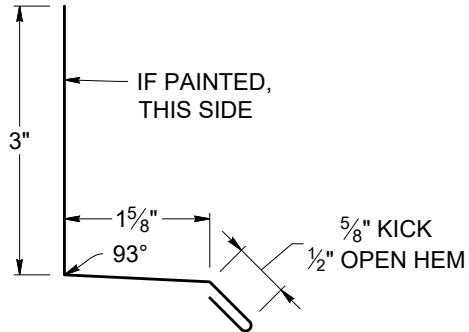

SCALE: 1:2 *WEIGHTS ARE BASED OFF OF 24 GAUGE COILS
S.O. 5.75" WEIGHT: 4.61 LBS

.875" BASE FLASHING COLOR INSERT - STANDOFF CLIP
(TKCTBFI0875)

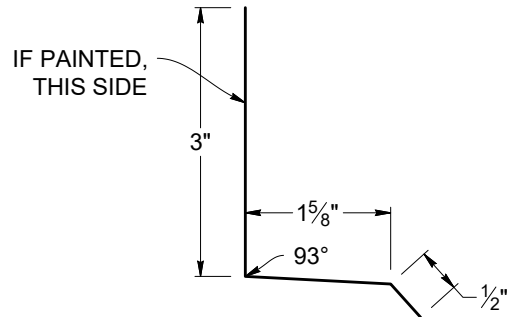

SCALE: 1:2 *WEIGHTS ARE BASED OFF OF 24 GAUGE COILS
S.O. 5.125" WEIGHT: 4.11 LBS

OUTSIDE CORNER - TYPE A - STANDOFF CLIP
(TKCTCOAS)

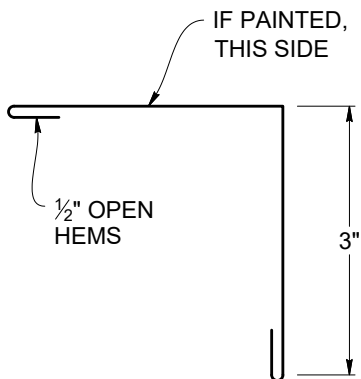

SCALE: 1:2 S.O. 7" WEIGHT: 5.8 LBS.

INSIDE CORNER - TYPE A - STANDOFF CLIP
(TKCTCIAS)

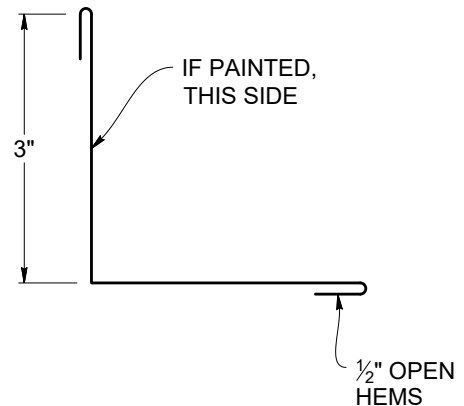

SCALE: 1:2 S.O. 7" WEIGHT: 5.8 LBS.

SUPPORT FLASHING CAP - STANDOFF CLIP
(TKCTSFC5)

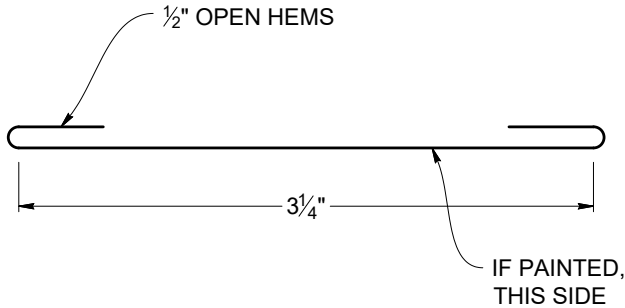

SCALE: 1:1 S.O. 4.25" WEIGHT: 3.35 LBS.

.875" NARROW REVEAL SPLICE - STANDOFF CLIP
(TKCTNRS0875)

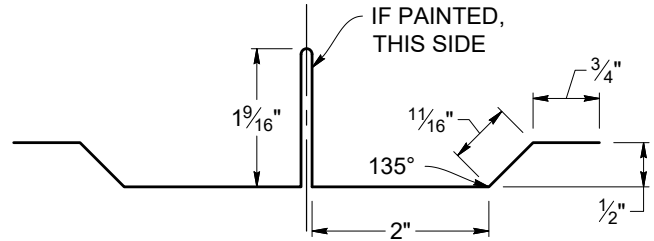

SCALE: 1:2 *WEIGHTS ARE BASED OFF OF 24 GAUGE COILS
S.O. 10" WEIGHT: 8.14 LBS.

.875" C-FLASHING - STANDOFF CLIP
(TKCTCFO875)

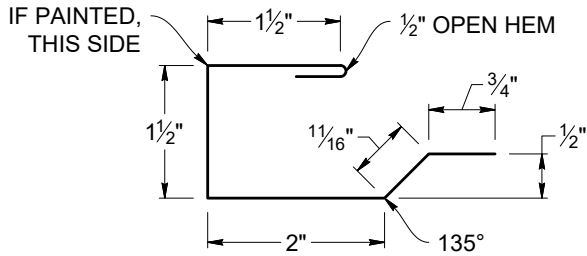

SCALE: 1:2 *WEIGHTS ARE BASED OFF OF 24 GAUGE COILS
S.O. 6.9375" WEIGHT: 5.57 LBS

.875" SUPPORT FLASHING - STANDOFF CLIP
(TKCTSFO875)

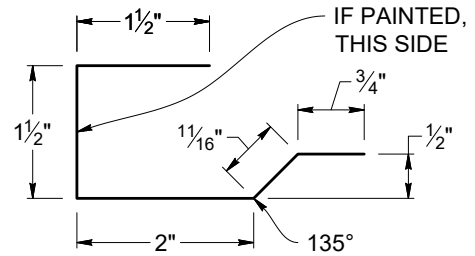

SCALE: 1:2 *WEIGHTS ARE BASED OFF OF 24 GAUGE COILS
S.O. 6.4375" WEIGHT: 5.17 LBS

Contour Flashings - .875" Height

Flashing and Details Selection

Flashing: 10' Standard



TROUGH FLASHING - STANDOFF CLIP
(TK CTTFS)

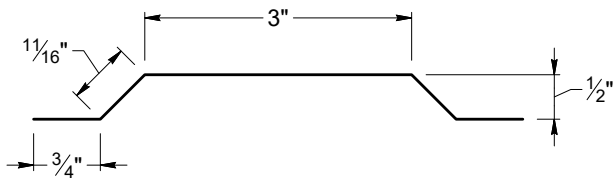

SCALE: 1:2

S.O. 5.875"

WEIGHT: 4.81 LBS.

.875" SILL FLASHING - STANDOFF CLIP
(TKCTFS0875)

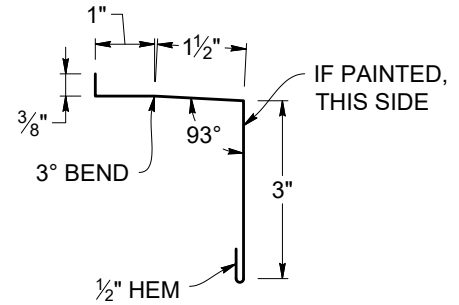

SCALE: 1:3

*WEIGHTS ARE BASED OFF OF 24 GAUGE COILS
S.O. 5.375"

WEIGHT: 5.11 LBS

OFFSET CLEAT - STANDOFF CLIP
(TKCTOCOS)

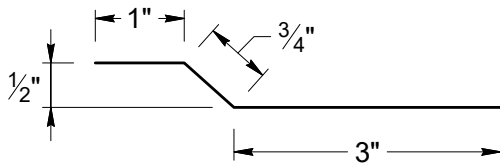

SCALE: 1:2

S.O. 4.75"

WEIGHT: 3.35 LBS.

Zig Zag

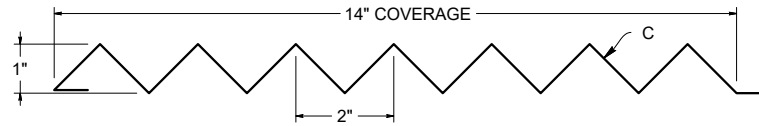

C-7

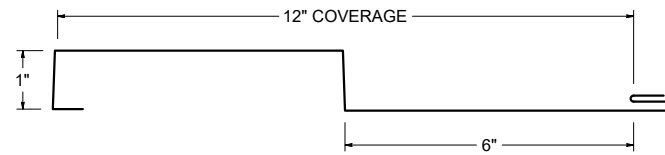

CR-A

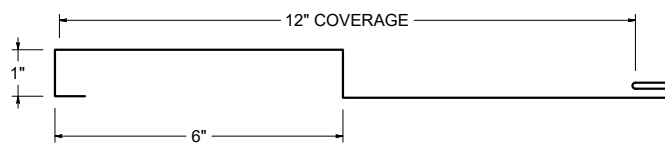

CR-B

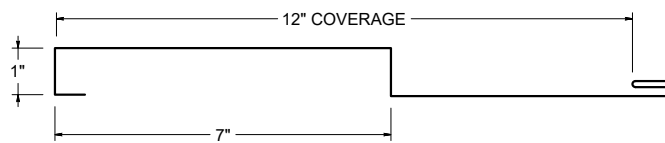

CR-C

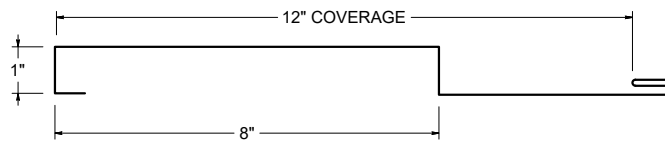

CR-D

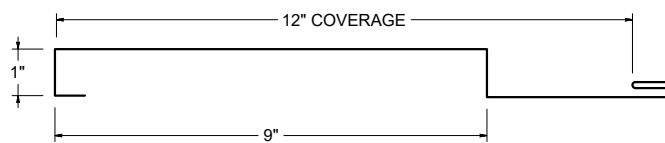

CR-E

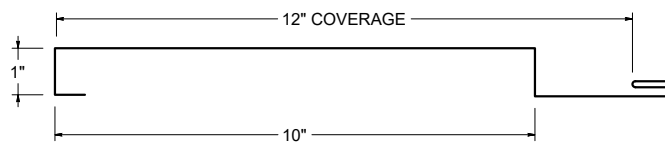

CR-F

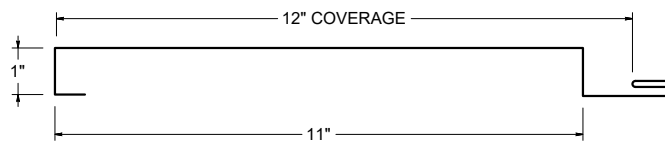

CR-G

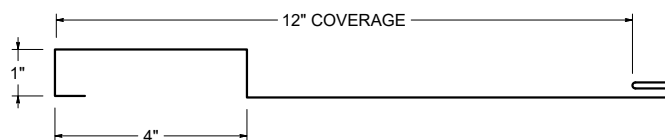

Contour Flashings - 1" Height

Flashing and Details Selection

Flashing: 10' Standard



1" BASE FLASHING - STANDOFF CLIP
(TKCTBFO100)

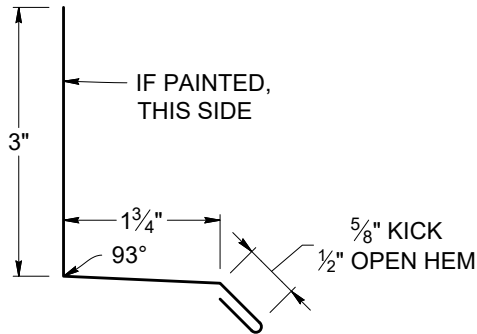

SCALE: 1:2 *WEIGHTS ARE BASED OFF OF 24 GAUGE COILS
S.O. 5.875" WEIGHT: 4.71 LBS

1" BASE FLASHING COLOR INSERT - STANDOFF CLIP
(TK CTBFIO100)

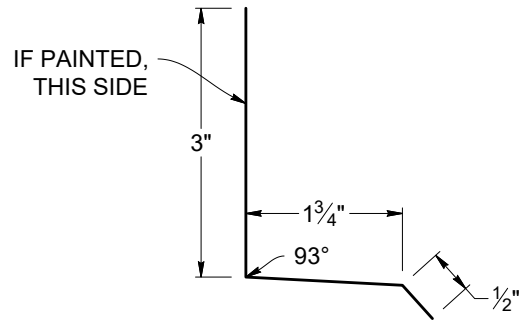

SCALE: 1:2 *WEIGHTS ARE BASED OFF OF 24 GAUGE COILS
S.O. 5.25" WEIGHT: 4.21 LBS

OUTSIDE CORNER - TYPE A - STANDOFF CLIP
(TKCTCOAS)

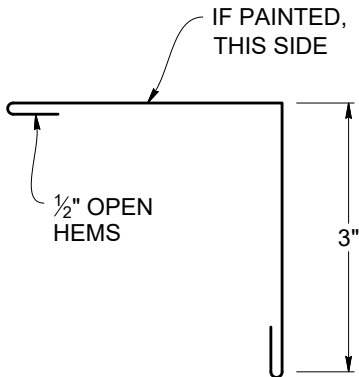

SCALE: 1:2 S.O. 7" WEIGHT: 5.8 LBS.

INSIDE CORNER - TYPE A - STANDOFF CLIP
(TKCTCIAS)

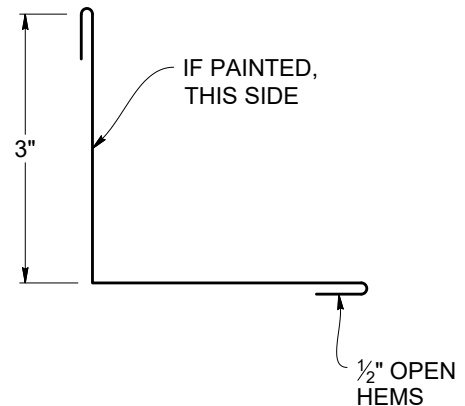

SCALE: 1:2 S.O. 7" WEIGHT: 5.8 LBS.

SUPPORT FLASHING CAP - STANDOFF CLIP
(TKCTSFCS)

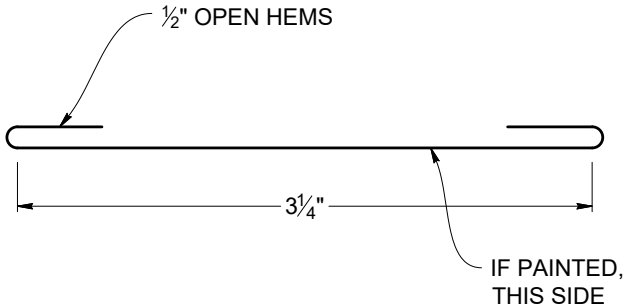

SCALE: 1:1 S.O. 4.25" WEIGHT: 3.35 LBS.

1" NARROW REVEAL SPLICE - STANDOFF CLIP
(TKCTNRSO100)

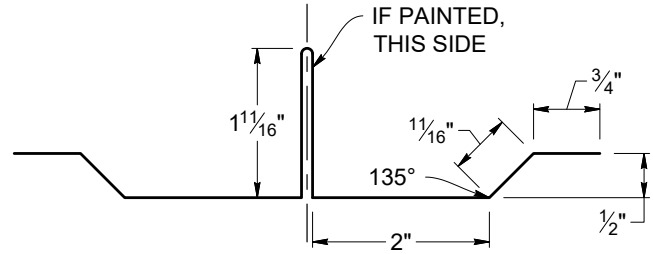

SCALE: 1:2 *WEIGHTS ARE BASED OFF OF 24 GAUGE COILS
S.O. 10.25" WEIGHT: 8.34 LBS.

1" C-FLASHING - STANDOFF CLIP
(TKCTCFO100)

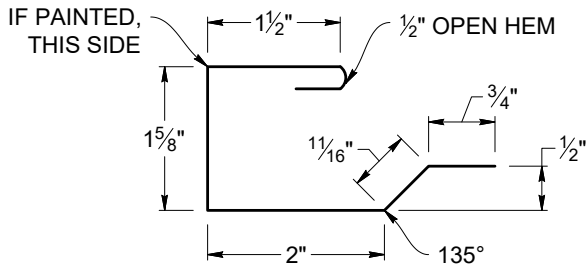

SCALE: 1:2 *WEIGHTS ARE BASED OFF OF 24 GAUGE COILS
S.O. 7.0625" WEIGHT: 5.67 LBS

1" SUPPORT FLASHING - STANDOFF CLIP
(TKCTSFO100)

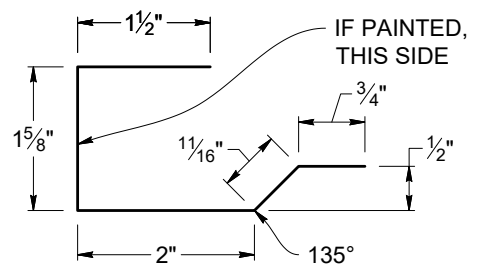

SCALE: 1:2 *WEIGHTS ARE BASED OFF OF 24 GAUGE COILS
S.O. 6.5625" WEIGHT: 5.27 LBS

Contour Flashings - 1" Height

Flashing and Details Selection

Flashing: 10' Standard



TROUGH FLASHING - STANDOFF CLIP
(TKCTTFS)

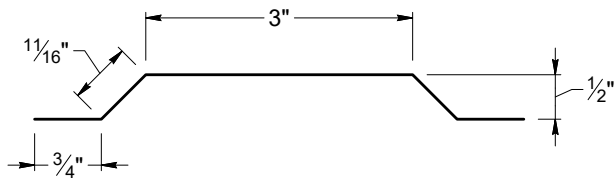

SCALE: 1:2

S.O. 5.875"

WEIGHT: 4.81 LBS.

1" SILL FLASHING - STANDOFF CLIP
(TKCTFSO100)

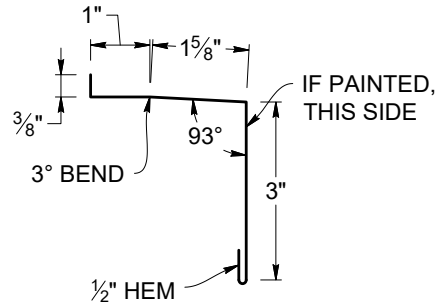

SCALE: 1:3

*WEIGHTS ARE BASED OFF OF 24 GAUGE COILS
S.O. 6.5"

WEIGHT: 5.22 LBS

OFFSET CLEAT - STANDOFF CLIP
(TKCTOCOS)

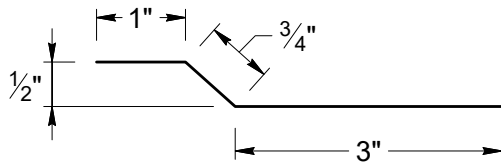

SCALE: 1:2

S.O. 4.75"

WEIGHT: 3.35 LBS.

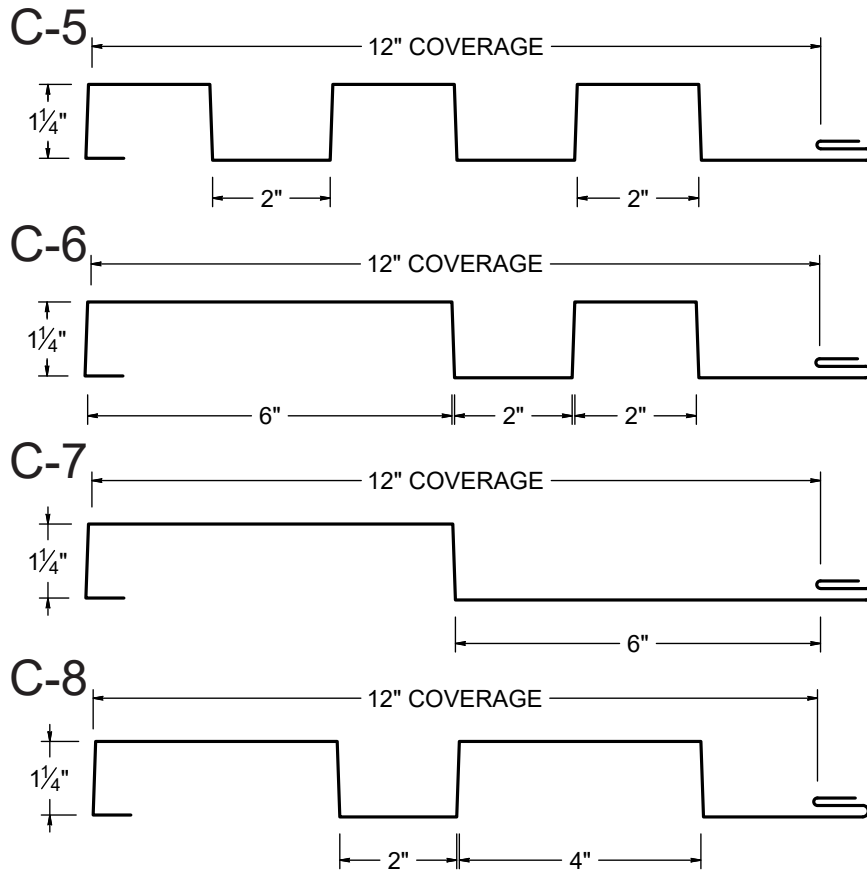

Contour Flashings - 1.25" Height

Flashing and Details Selection

Flashing: 10' Standard



1.25" BASE FLASHING - STANDOFF CLIP
(TK CTBFO125)

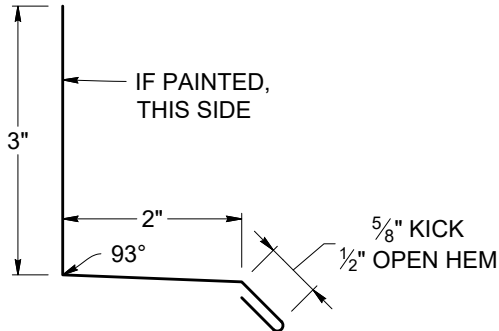

SCALE: 1:2 *WEIGHTS ARE BASED OFF OF 24 GAUGE COILS
S.O. 6.125" WEIGHT: 4.91 LBS

1.25" BASE FLASHING COLOR INSERT - STANDOFF CLIP
(TKCTBFO125)

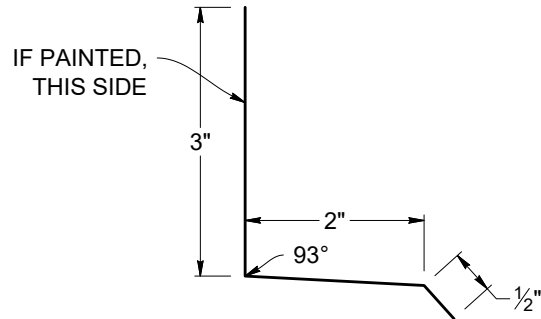

SCALE: 1:2 *WEIGHTS ARE BASED OFF OF 24 GAUGE COILS
S.O. 5.5" WEIGHT: 4.41 LBS

OUTSIDE CORNER - TYPE A - STANDOFF CLIP
(TKCTCOAS)

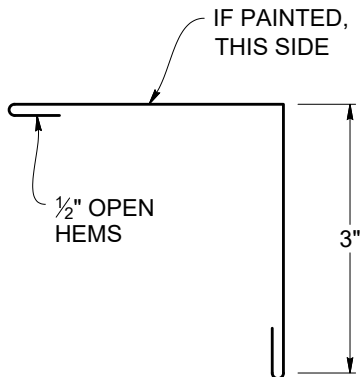

SCALE: 1:2 S.O. 7" WEIGHT: 5.8 LBS.

INSIDE CORNER - TYPE A - STANDOFF CLIP
(TKCTCIAS)

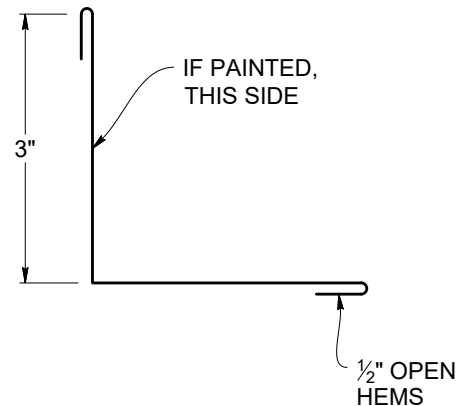

SCALE: 1:2 S.O. 7" WEIGHT: 5.8 LBS.

SUPPORT FLASHING CAP - STANDOFF CLIP
(TKCTSFC3)

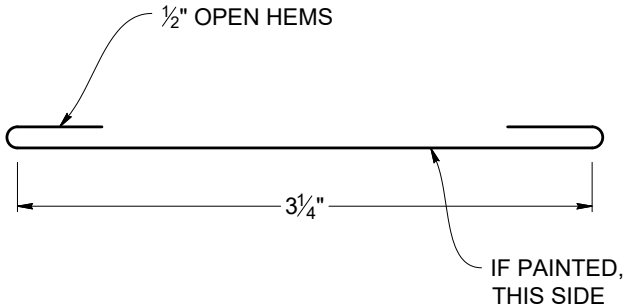

SCALE: 1:1 S.O. 4.25" WEIGHT: 3.35 LBS.

1.25" NARROW REVEAL SPLICE - STANDOFF CLIP
(TKCTNRSO125)

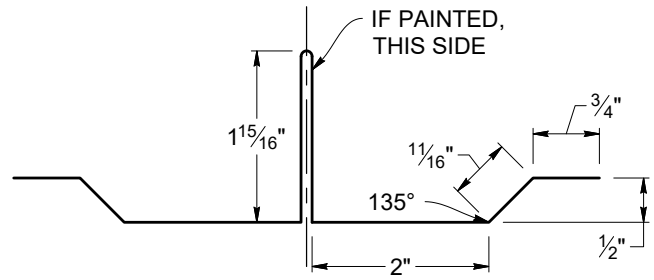

SCALE: 1:2 *WEIGHTS ARE BASED OFF OF 24 GAUGE COILS
S.O. 10.75" WEIGHT: 8.75 LBS.

1.25" C-FLASHING - STANDOFF CLIP
(TKCTCFO125)

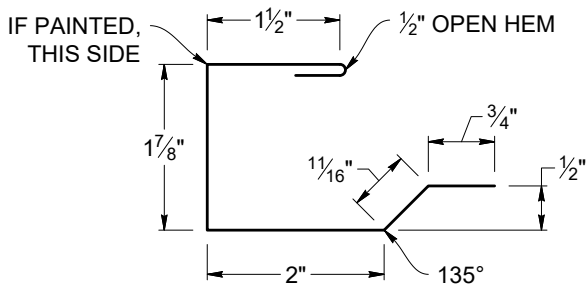

SCALE: 1:2 *WEIGHTS ARE BASED OFF OF 24 GAUGE COILS
S.O. 7.3125" WEIGHT: 5.87 LBS.

1.25" SUPPORT FLASHING - STANDOFF CLIP
(TKCTSFO125)

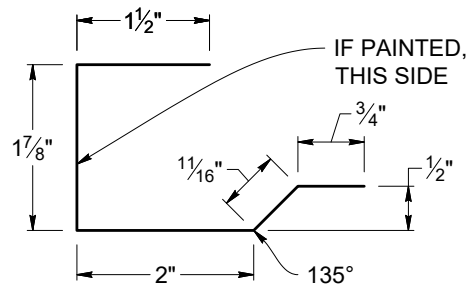

SCALE: 1:2 *WEIGHTS ARE BASED OFF OF 24 GAUGE COILS
S.O. 6.8125" WEIGHT: 5.47 LBS.

Contour Flashings - 1.25" Height

Flashing and Details Selection

Flashing: 10' Standard



TROUGH FLASHING - STANDOFF CLIP
(TKCTTFS)

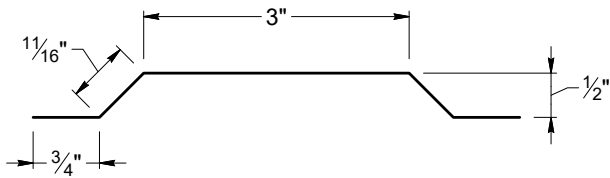

SCALE: 1:2

S.O. 5.875"

WEIGHT: 4.81 LBS.

1.25" SILL FLASHING - STANDOFF CLIP
(CTFSO125)

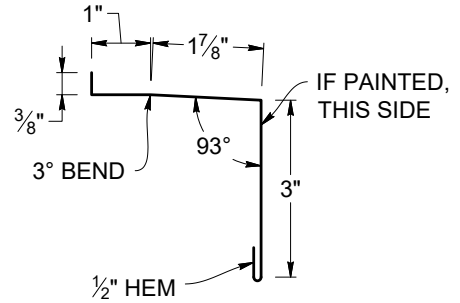

SCALE: 1:3

*WEIGHTS ARE BASED OFF OF 24 GAUGE COILS
S.O. 6.75"

WEIGHT: 5.42 LBS.

OFFSET CLEAT - STANDOFF CLIP
(TKCTOCOS)

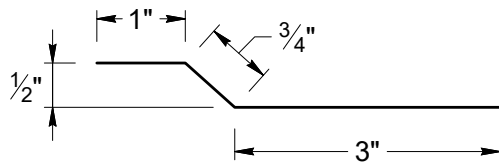

SCALE: 1:2

S.O. 4.75"

WEIGHT: 3.35 LBS.

Cascade 1

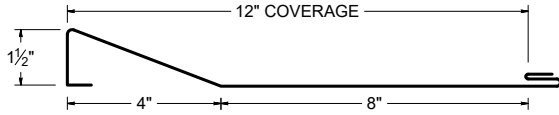

Cascade 2

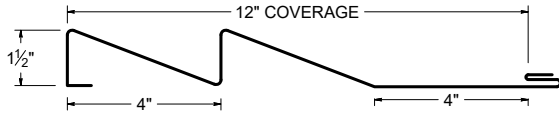

Cascade 3

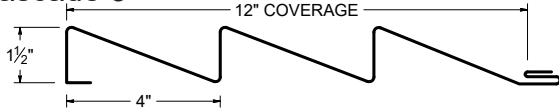

Cascade 4

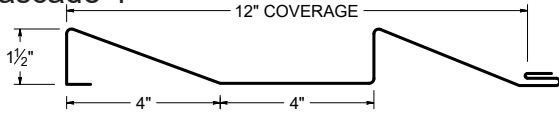

Chevron V



Chevron W

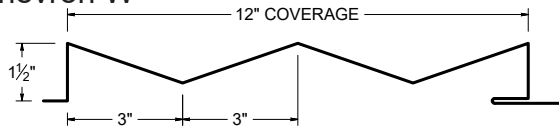

C-5

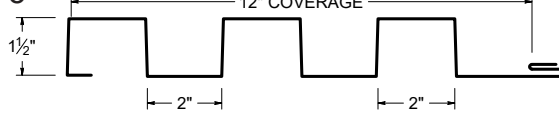

C-6

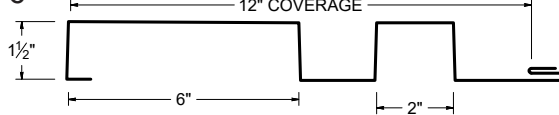

C-7

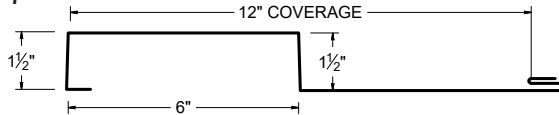

C-8

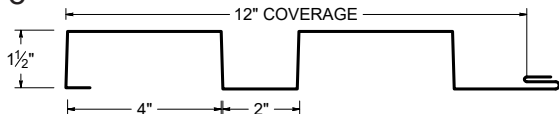

C-9

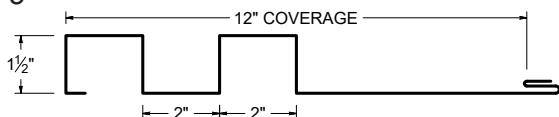

C-10

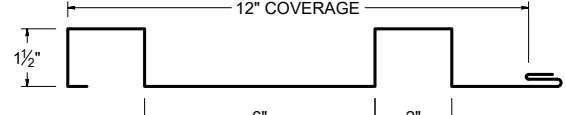

C8-A

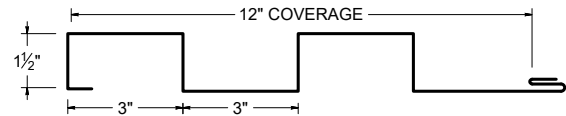

C8-B

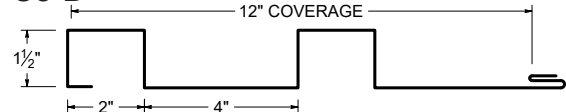

C9-A

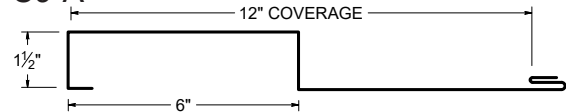

Chevron V

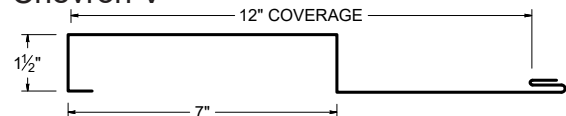

Chevron W

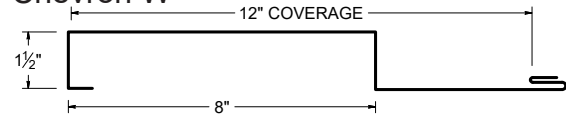

CR-A

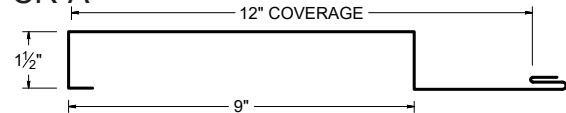

CR-B

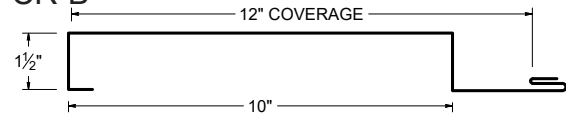

CR-D

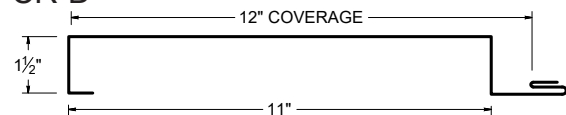

CR-E

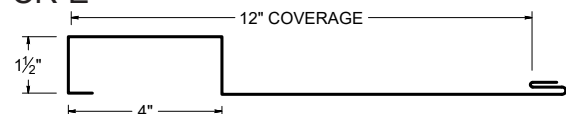

CR-F

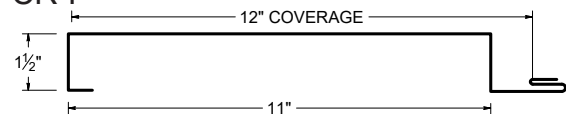

CR-G

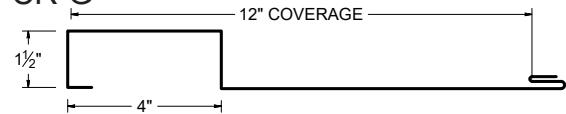

Contour Flashings - 1.5" Height

Flashing and Details Selection

Flashing: 10' Standard



1.5" BASE FLASHING - STANDOFF CLIP
(TKCTBFO150)

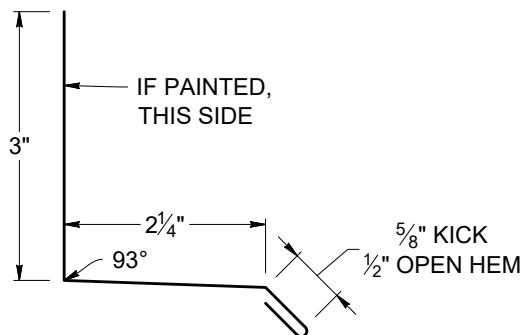

SCALE: 1:2 *WEIGHTS ARE BASED OFF OF 24 GAUGE COILS
S.O. 6.375" WEIGHT: 5.11 LBS

1.5" BASE FLASHING COLOR INSERT - STANDOFF CLIP
(TKCTBFO150)

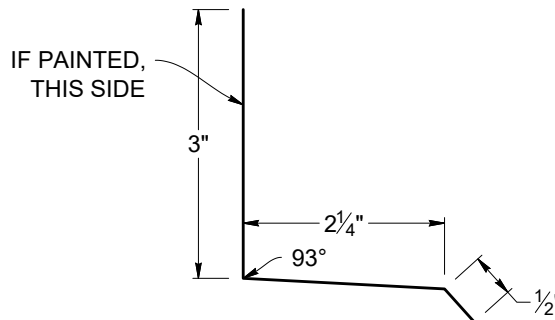

SCALE: 1:2 *WEIGHTS ARE BASED OFF OF 24 GAUGE COILS
S.O. 5.75" WEIGHT: 4.61 LBS

OUTSIDE CORNER - TYPE A - STANDOFF CLIP
(TKCTCOAS)

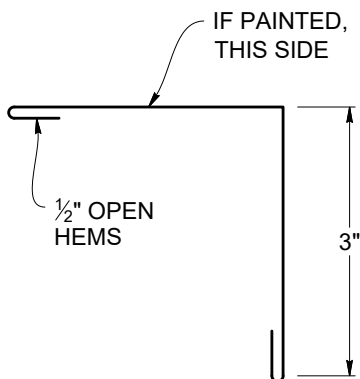

SCALE: 1:2 S.O. 7" WEIGHT: 5.8 LBS.

INSIDE CORNER - TYPE A - STANDOFF CLIP
(TKCTCIAS)

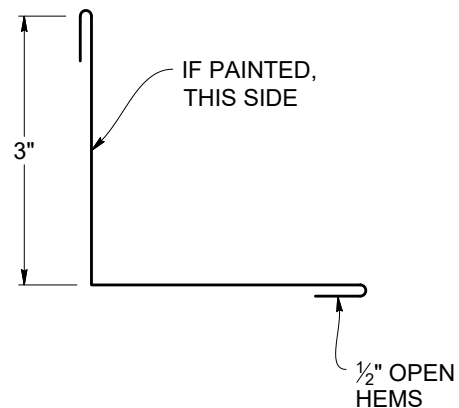

SCALE: 1:2 S.O. 7" WEIGHT: 5.8 LBS.

SUPPORT FLASHING CAP - STANDOFF CLIP
(TKCTSFCS)

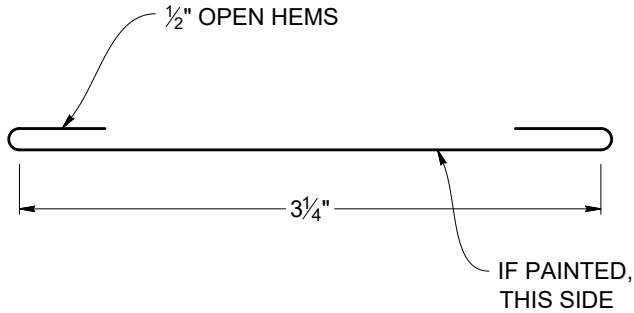

SCALE: 1:1 S.O. 4.25" WEIGHT: 3.35 LBS.

1.5" NARROW REVEAL SPLICE - STANDOFF CLIP
(TKCTNRSO150)

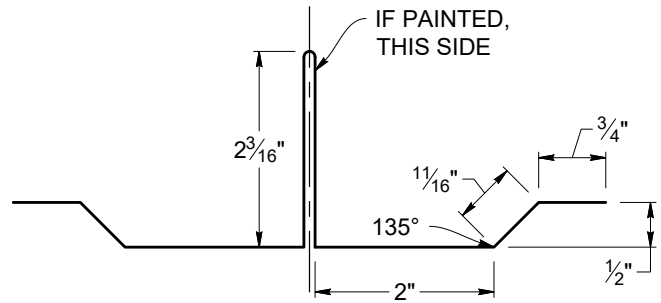

SCALE: 1:2 *WEIGHTS ARE BASED OFF OF 24 GAUGE COILS
S.O. 11.25" WEIGHT: 9.15 LBS.

1.5" C-FLASHING - STANDOFF CLIP
(TKCTCFO150)

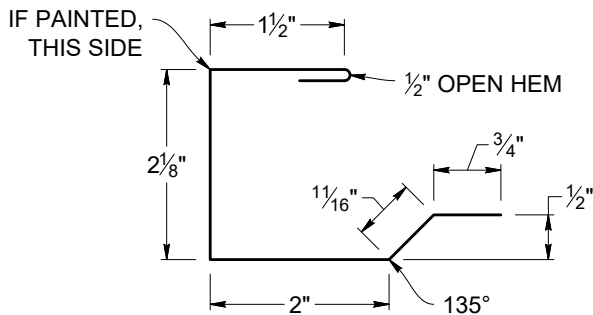

SCALE: 1:2 *WEIGHTS ARE BASED OFF OF 24 GAUGE COILS
S.O. 7.5625" WEIGHT: 6.07 LBS.

1.5" SUPPORT FLASHING - STANDOFF CLIP
(TKCTSFO150)

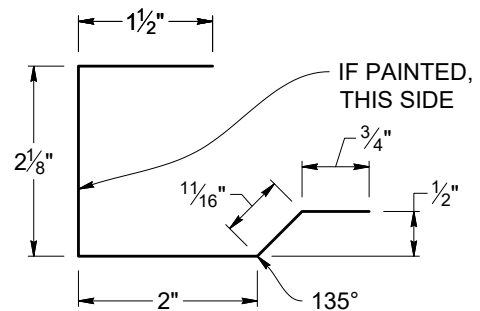

SCALE: 1:2 *WEIGHTS ARE BASED OFF OF 24 GAUGE COILS
S.O. 7.0625" WEIGHT: 5.67 LBS.

Contour Flashings - 1.5" Height

Flashing and Details Selection

Flashing: 10' Standard



TROUGH FLASHING - STANDOFF CLIP
(TKCTTFS)

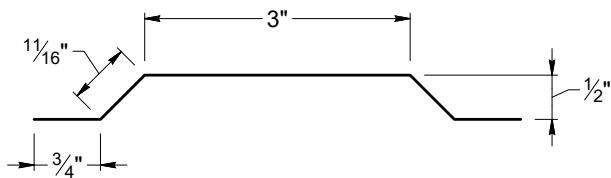

SCALE: 1:2

S.O. 5.875"

WEIGHT: 4.81 LBS.

1.5" SILL FLASHING - STANDOFF CLIP
(TKCTFSO150)

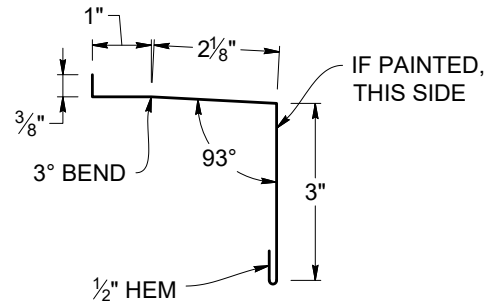

SCALE: 1:3

*WEIGHTS ARE BASED OFF OF 24 GAUGE COILS
S.O. 7"

WEIGHT: 5.62 LBS.

OFFSET CLEAT - STANDOFF CLIP
(TKCTOCOS)

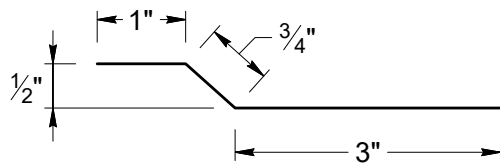

SCALE: 1:2

S.O. 4.75"

WEIGHT: 3.35 LBS.

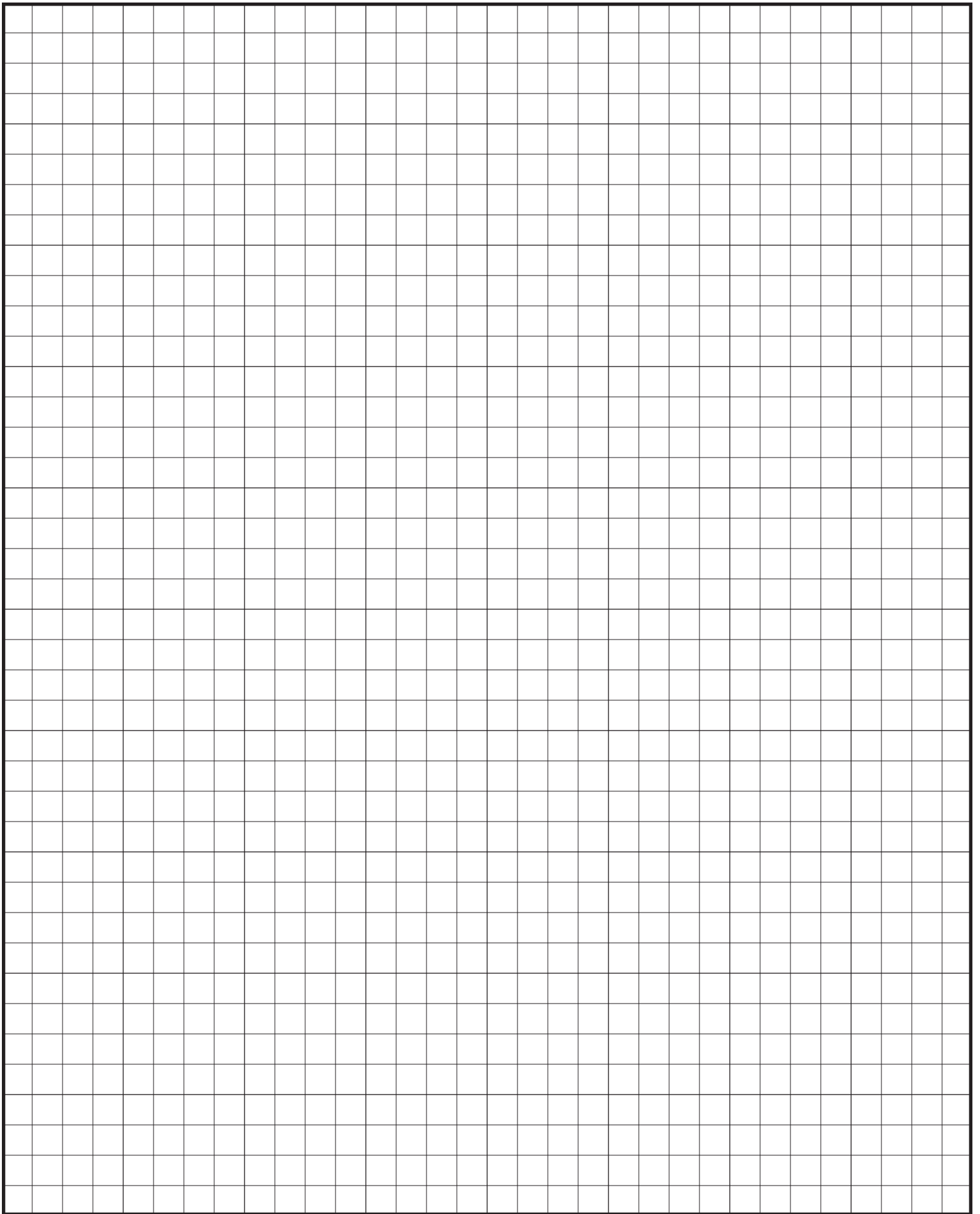



Custom Trim Order

Customer Name: _____ Job Name: _____

Gauge: _____ Color: _____ Status: Original New

Specify: Angles Color Side Dimensions Stretchout

SO _____

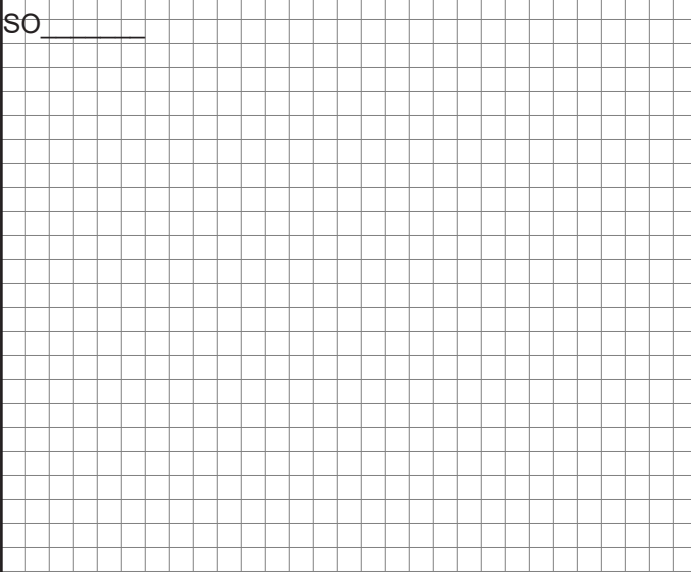

Dwg #: _____ Pitch: _____ # of Pieces: _____

Description: _____

Hems: Open Closed Slightly Open

SO _____

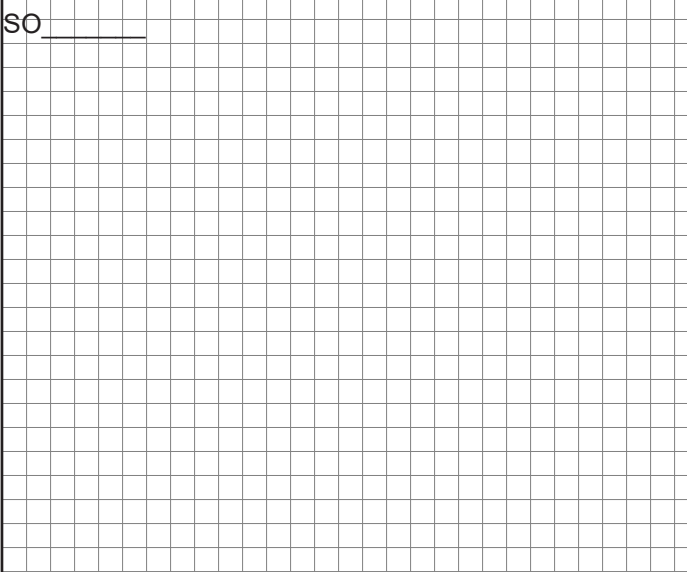

Dwg #: _____ Pitch: _____ # of Pieces: _____

Description: _____

Hems: Open Closed Slightly Open

SO _____

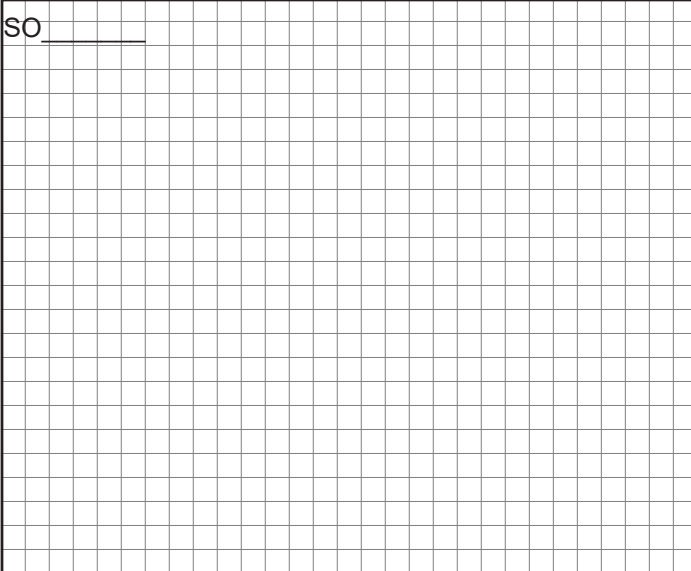

Dwg #: _____ Pitch: _____ # of Pieces: _____

Description: _____

Hems: Open Closed Slightly Open

SO _____

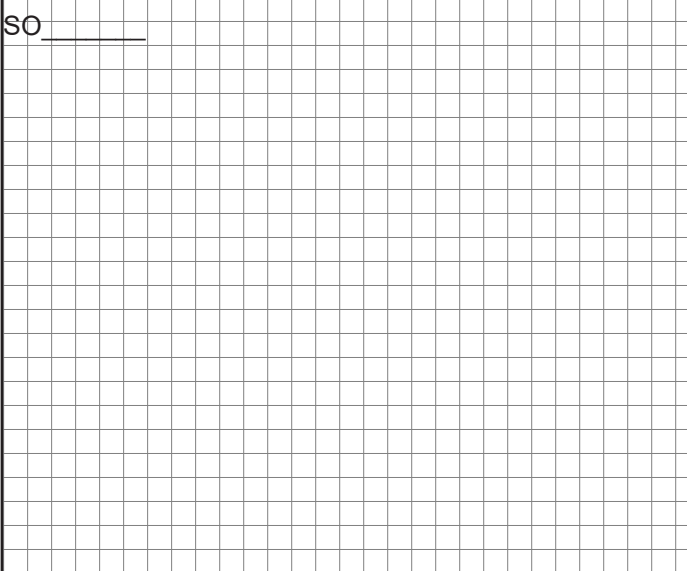

Dwg #: _____ Pitch: _____ # of Pieces: _____

Description: _____

Hems: Open Closed Slightly Open

Please provide a drawing for each flashing with precise measurements and angles

Fax to: 503-581-6877

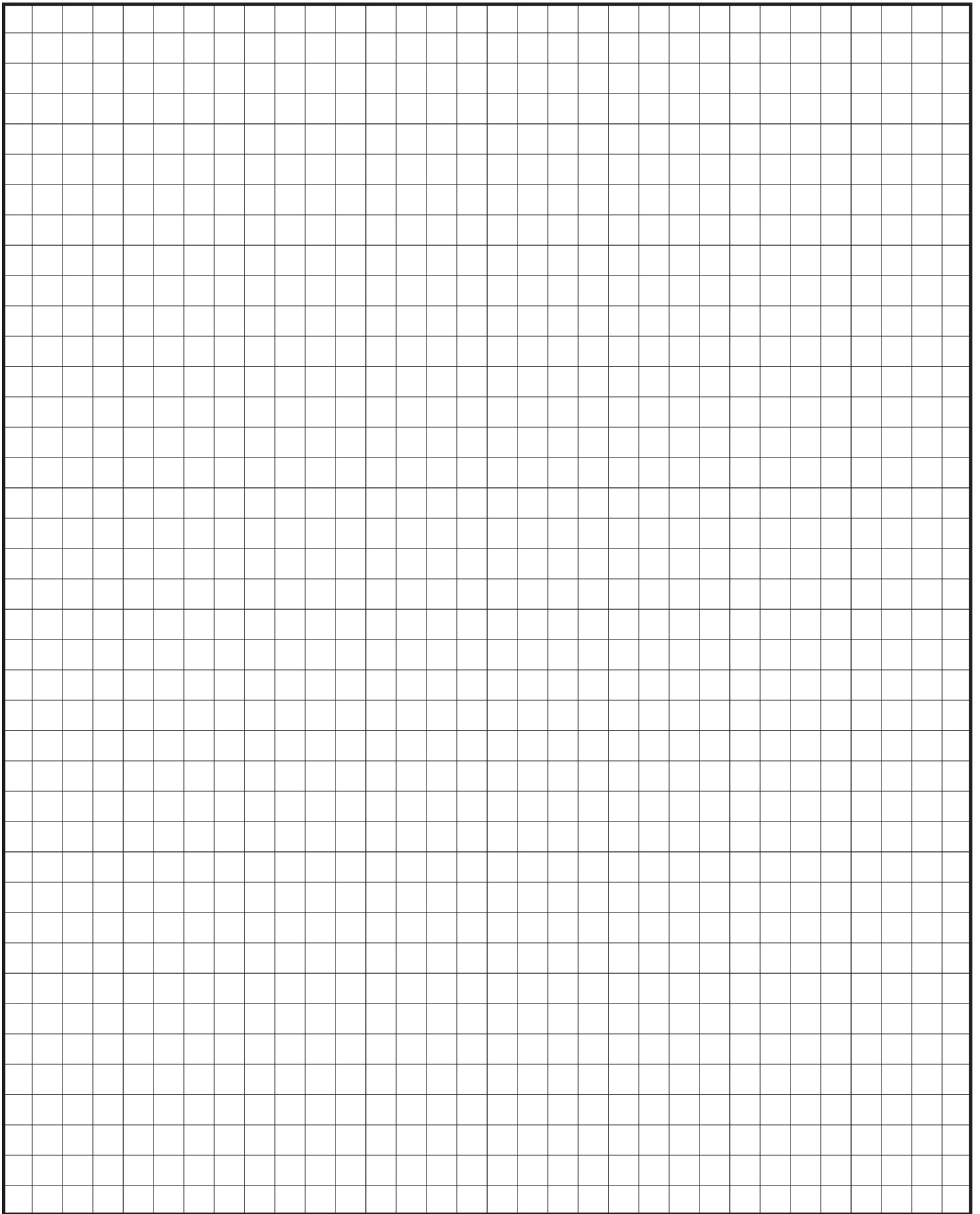



Custom Trim Order

Customer Name: _____ Job Name: _____

Gauge: _____ Color: _____ Status: Original New

Specify: Angles Color Side Dimensions Stretchout

SO _____

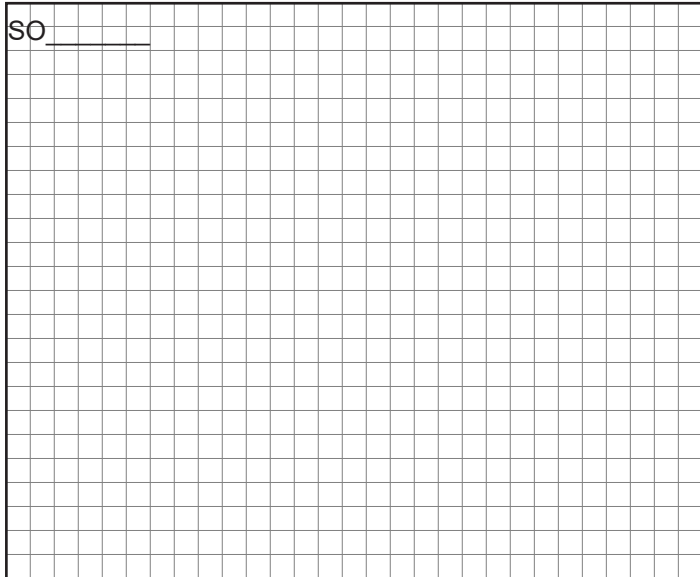

Dwg #: _____ Pitch: _____ # of Pieces: _____

Description: _____

Hems: Open Closed Slightly Open

SO _____

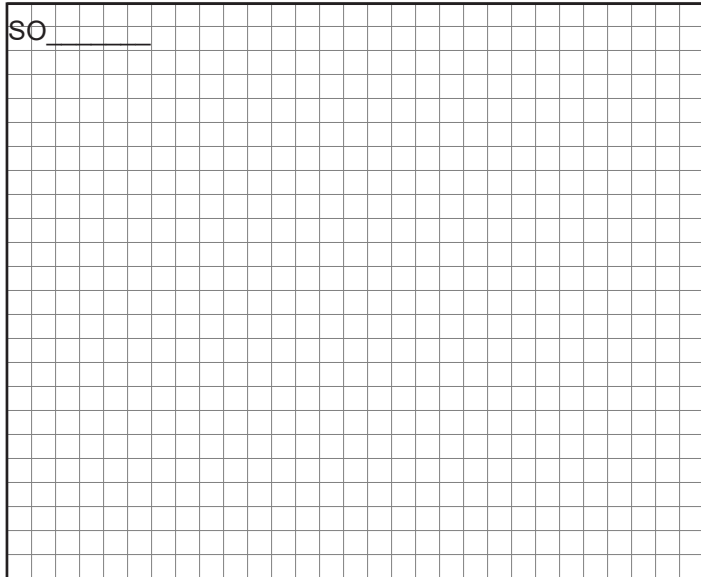

Dwg #: _____ Pitch: _____ # of Pieces: _____

Description: _____

Hems: Open Closed Slightly Open

SO _____

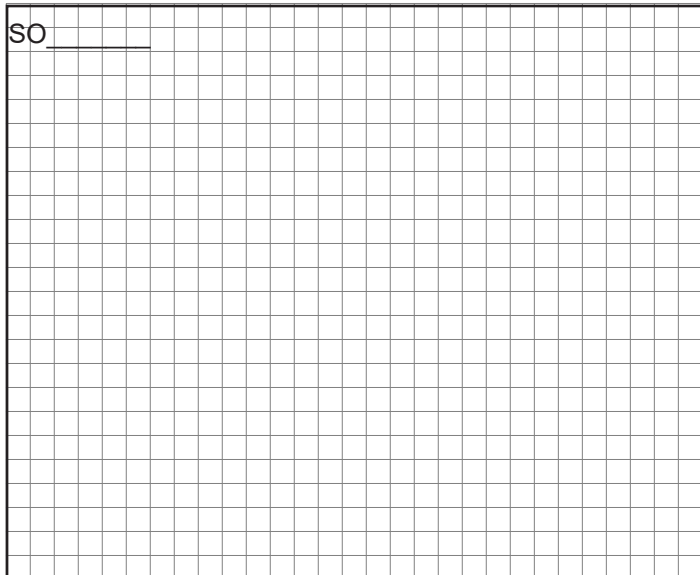

Dwg #: _____ Pitch: _____ # of Pieces: _____

Description: _____

Hems: Open Closed Slightly Open

SO _____

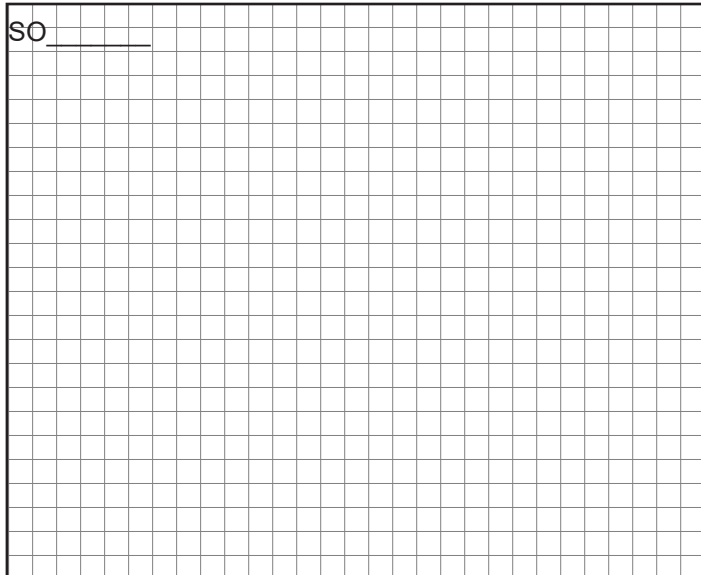

Dwg #: _____ Pitch: _____ # of Pieces: _____

Description: _____

Hems: Open Closed Slightly Open

Please provide a drawing for each flashing with precise measurements and angles

Fax to: 503-581-6877



TAYLOR

METAL PRODUCTS

QUALITY PRODUCTS
EXCEPTIONAL SERVICE

SALEM BRANCH

4566 Ridge Dr. NE
Salem, OR 97301

Office: 503-581-8338
Toll Free: 1-800-574-1388
Fax: 503-581-6877

SACRAMENTO BRANCH

3443 Airport Rd,
Sacramento, CA 95834

Office: 916-318-8844
Toll Free: 1-800-574-1388
Fax: 916-993-4123

SPOKANE BRANCH

1010 N Nelson St.,
Spokane, WA 99202
www.go-rsp.com

Office: 509-535-8667
Toll Free: 800-238-4057
Fax: 509-535-8682

AUBURN BRANCH

2601 C St SW,
Auburn, WA 98001

Office: 206-900-9923
Toll Free: 1-800-574-1388
Fax: 253-804-3545

RIVERSIDE BRANCH

4880 Felspar St.
Riverside, CA 92509

Office: 323-407-7457
Toll Free: 1-877-504-1594