

STRIATIONS

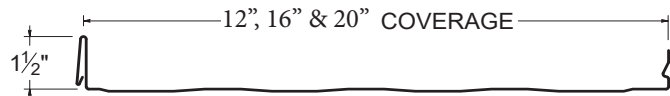

CLIP RELIEF

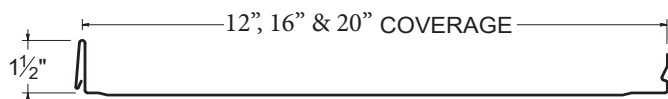

FLAT

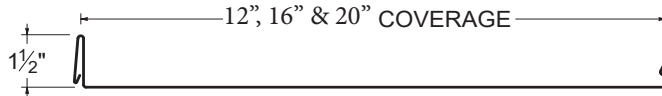

ACCENT RIBS

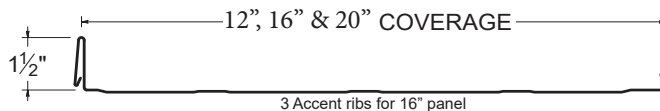

PANEL CLIPS

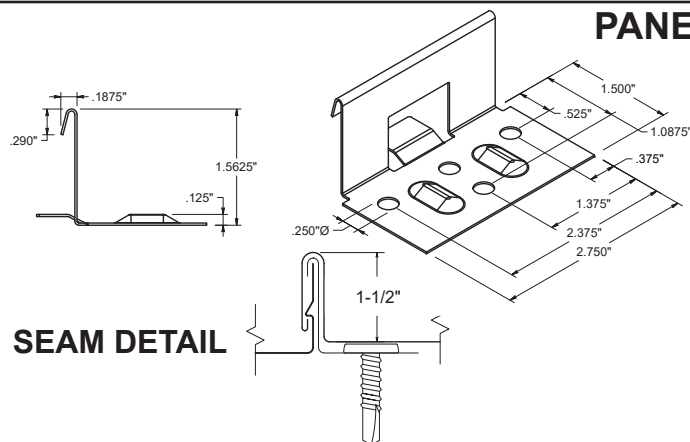

SEAM DETAIL

Clip spacing

Panel clip spacing is based on structural design loads, engineered spanning capability of the panels and substrate.

Fasteners



All fasteners going into steel or plywood must extend at least 3 full threads beyond the material. When attaching to dimensional lumber, 1" embedment is required.

STANDARD CLIP: for U.S. rated and engineered solid deck applications. Accommodates for unlimited thermal movement in both directions. Clips are fabricated from Grade 50 G90 base steel, 18 ga.

KEY FEATURES

- 12", 16" & 20" nominal coverage options
(Nominal coverage - panel coverage can vary slightly with some panel configurations. Inquire for more details)
- 24 & 22 Tru-Gauge™
- 16 & 20 oz. Copper *(Please inquire)*
- Floating clip system: allows for expansion & contraction of panels in longer lengths
- 1-1/2" vertical rib
- Standard factory notched panels
- Concealed fasteners: fasteners cannot leak
- 3:12 minimum pitch recommended
(For lower pitches, please inquire)
- Standard panel lengths 4' to 60'
Minimum length 2' Notched
Minimum length 1' Not Notched
(For longer panels, please inquire)
- 2' Shortcut capability *(Fee applicable)*
- Onsite roll forming available
- Panel options: Striations, Accent Ribs, and Flat Pan
- Manufactured in Salem, OR

TESTING

-  ICC EVALUATION SERVICE™ ICC #5046 with CBC-CRC Supplement
-  Code compliance UL Evaluation Report UL ER #25913-01
- UL Construction No. 589
(Slim-Lock™ carries its UL Classifications under the Clip-Lock 150 (CA) profile designation)
- UL 580 Class 90 - Wind Uplift
- UL 790 Class A (ASTM E108) - Fire rated
- UL 2218 Class 4 - Impact (hail) rated
- ASTM A653/A924 - G90 Galvanized
- ASTM A792 - Zincalume/Galvalume AZ-50/55
- ASTM B209 - Aluminum Substrate
- ASTM E2886 - Ember Resistant ridge/endwall/peak flashings available

WEIGHT CHART

Slim-Lock	WIDTH	24 GA STEEL	22 GA STEEL	.040" ALUM
THICKNESS		0.0236"	0.0285"	0.040"
WEIGHT/LINFT	12"	1.314 LBS	1.587 LBS	0.778 LBS
WEIGHT/SQFT	12"	1.314 LBS	1.587 LBS	0.778 LBS
WEIGHT/LINFT	16"	1.635 LBS	1.974 LBS	0.968 LBS
WEIGHT/SQFT	16"	1.226 LBS	1.481 LBS	0.726 LBS
WEIGHT/LINFT	20"	1.956 LBS	2.362 LBS	1.158 LBS
WEIGHT/SQFT	20"	1.173 LBS	1.417 LBS	0.695 LBS

THEORETICAL LOAD CHART

Allowable Strength Design (ASD)

Wind Load Factor = 1.00

Allowable Uniform Load (psf)

Span	Deflection	Span Length (Feet)								
		2.00	2.25	2.50	2.75	3.00	3.25	3.50	3.75	4.00
1	L/180	118	93	75	62	52	44	38	33	29
	L/240	118	93	75	62	52	44	38	33	29
	L/360	118	93	75	62	52	44	38	33	28
2	L/180	118	93	75	62	52	44	38	33	29
	L/240	118	93	75	62	52	44	38	33	29
	L/360	118	93	75	62	52	44	38	33	29
3	L/180	136	107	87	72	60	51	44	38	33
	L/240	136	107	87	72	60	51	44	38	33
	L/360	136	107	87	72	60	51	44	38	33

- Charted Load/Span values are based on ASTM E1592-05 testing protocol
- Charted Allowable Uniform Loads are based on the Ultimate Uniform Load (per ASTM E1592 testing) divided by 2.00 Factor-of-Safety.
- Minimum recommended substrate (structure) recommendations:
 - A. Open-framing (i.e. purlins) - 16 ga (design thickness = 0.0566")
 - B. Plywood/OSP - 15/32" or thicker is recommended to assure an effective degree of fastener thread engagement.
 - C. Metal deck - 22 ga (design thickness = 0.0283)

#12 Hex-Head screws for panel attachment to substrate

#14 LapTek screws at panel lap, 12" OC

#14 Type S screws for CDX or OSB applications