

ES ICC EVALUATION SERVICE® **ICC-ES EVALUATION REPORT #5046 with CBC-CRC Supplement**

STRIATIONS

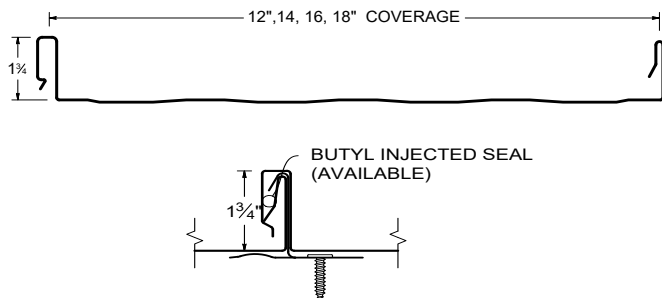

FLAT

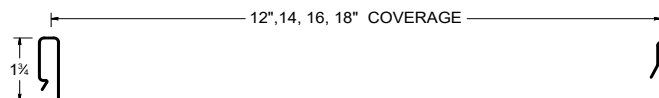

FLAT ACCENT RIBS

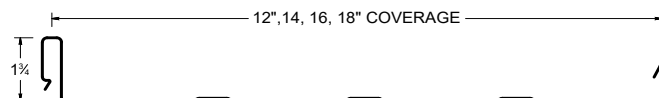

2 Accent ribs for 12" & 14" panels
3 Accent ribs for 16" & 18" panels

KEY FEATURES

- 12", 14", 16" & 18" coverage options
- 24 and 22 Tru-Gauge™ and .032" and .040 Aluminum
- Floating clip system: allows for expansion and contraction of panels in longer lengths
- 1-3/4" vertical rib, factory notching available
- 2:12 minimum pitch recommended (For lower pitches, please inquire)
- Standard panel lengths 1' to 60' (For longer length panels, please inquire)
- On-site roll forming available for longer panels
- Factory injected Butyl sealant available
- Clip Relief is not standard, available upon request
- Wide Batten incorporates nicely over Versa-Span™ standing seam panel (*separate clip required*)
- Weathertightness warranty available (Contact TMP representative for details)
- Manufactured in Salem OR

TESTING

- **ES** ICC EVALUATION SERVICE® ICC-ESR #5046 with CBC-CRC Supplement
- **UL** Code compliance UL Evaluation Report UL ER #25913-01
- UL Construction No. 254, 255, 261, 303, 342, 343, 414, 436, 445, 447, 448, 486, 508, 508A, 543, 544
- UL 580 Class 90 - Wind Uplift
- UL 790 Class A (ASTM E108) - Fire rated
- UL 2218 Class 4 - Impact (hail) rated
- ASTM E1680 - Air infiltration (roof)
- ASTM E1646 - Water infiltration (roof)
- ASTM E1592 - Structural uniform static air pressure
- ASTM E1514 Standard for Structural Standing steel roof panels systems.
- ASTM E331 - Water infiltration (wall)
- ASTM E283 - Air infiltration (wall)
- ASTM A653/A924 - G90 Galvanized
- ASTM A792 - ZINCALUME/Galvalume AZ-50/55
- ASTM B209 - Aluminum Substrate
- ASTM E2886 - Ember Resistant ridge/endwall/peak flashings available

WEIGHT CHART

Versa Span	WIDTH	24 GA STEEL	22 GA STEEL	.032" ALUM	.040" ALUM
THICKNESS		0.0236"	0.0285	0.032"	0.040"
WEIGHT/LINFT	12"	1.444 LBS	1.743 LBS	0.684 LBS	0.855 LBS
WEIGHT/SQFT	12"	1.444 LBS	1.743 LBS	0.684 LBS	0.855 LBS
WEIGHT/LINFT	14"	1.604 LBS	1.930 LBS	0.760 LBS	0.960 LBS
WEIGHT/SQFT	14"	1.375LBS	1.661 LBS	0.651 LBS	0.815 LBS
WEIGHT/LINFT	16"	1.765 LBS	2.131 LBS	0.836 LBS	1.045 LBS
WEIGHT/SQFT	16"	1.324 LBS	1.598 LBS	0.627 LBS	0.784 LBS
WEIGHT/LINFT	18"	1.925 LBS	2.325 LBS	0.912 LBS	1.140 LBS
WEIGHT/SQFT	18"	1.284 LBS	1.550 LBS	0.608 LBS	0.760 LBS

ASTM E 1680/E283 Air Penetration	ASTM E 1646/E331 Water Penetration
25 PSF<0.01 CFM/ft²-PASS	40 PSF - Pass
Force Engineering Test Result 696-0018T-21A-C	
Force Engineering Test Result 696-0018T-21D-F	

NEGATIVE LOAD CHART

				SECTION PROPERTIES						ALLOWABLE UNIFORM LOADS, psf For various clip spacings (i.e. span values)						
Width, in.	Gauge	Yield ksi	Weight psf	Top in Compression			Bottom in Compression			Negative Load						
				l_{xx} in ⁴ /ft.	l_{xx} (eff) in ⁴ /ft.	S_{xx} in ³ /ft.	l_{xx} in ⁴ /ft.	l_{xx} (eff) in ⁴ /ft.	S_{xx} in ³ /ft.	1'	1.5'	2'	2.5'	3'	3.5'	4'
16	24	50	1.36	0.1549	0.1370	0.0789	0.0925	0.1106	0.0908	83.2	73.6	64.1	54.6	45.0	35.5	26.0
16	22	50	1.71	0.2040	0.1800	0.1010	0.1210	0.1451	0.1213	93.6	87.1	78.0	68.9	59.8	50.7	41.6
18	24	50	1.28	0.1400	0.1230	0.0708	0.0820	0.0988	0.0809	67.6	59.8	52.0	44.2	36.4	28.6	20.8
18	22	50	1.61	0.1850	0.1620	0.0880	0.1070	0.1296	0.1079	90.1	79.8	69.6	59.3	49.1	38.8	28.6
16	0.032	19	0.64	0.1420	0.1420	0.0961	0.1420	0.1420	0.4760	46.8	42.4	38.1	33.8	29.4	25.1	20.8
18	0.032	19	0.62	0.2070	0.2070	0.1220	0.2070	0.2070	0.5696	54.6	48.5	42.4	36.4	30.3	24.2	18.2

- Charted Load/Span values are based on ASTM E1592-02 / ASTM E1592-05 testing protocol. Intertek Test Result M0874.01-901-44
- Charted Allowable Uniform Loads are based on the Ultimate Uniform Load (per ASTM E1592-05 testing) divided by 2.00 Factor-of-Safety.
- Minimum recommended substrate (structure) recommendations:
 - o Open-framing (i.e.purlins) -16ga (design thickness=0.0566")
 - o Plywood/OSB - 15/32" or thicker is recommend to assure an effective degree of fastener thread engagement.
 - o Metal deck - 22 ga. (design thickness=0.0283")

POSITIVE LOAD CHART

				SECTION PROPERTIES						ALLOWABLE UNIFORM LOADS, psf For various clip spacings (i.e. span values)									
Width, in.	Gauge	Yield ksi	Weight psf	Top in Compression			Bottom in Compression			Positive Load									
				l_{xx} in ⁴ /ft.	l_{xx} (eff) in ⁴ /ft.	S_{xx} in ³ /ft.	l_{xx} in ⁴ /ft.	l_{xx} (eff) in ⁴ /ft.	S_{xx} in ³ /ft.	2'	2.5'	3'	3.5'	4'	4.5'	5'	5.5'	6'	8'
12	24	50	1.47	0.1299	0.1095	0.0907	0.0596	0.0800	0.0638	278.2	222.6	177.2	130.2	99.7	78.8	63.8	52.7	44.3	24.9
12	22	50	1.875	0.1645	0.1401	0.1157	0.0804	0.1048	0.0827	440.0	330.8	229.7	168.8	129.2	102.1	82.7	68.4	57.4	32.3
12	0.032"	19	0.700	0.1770	0.1770	0.1245	0.1770	0.1770	0.4904	50.5	40.4	33.6	28.8	25.2	22.4	20.2	18.0	15.1	8.5
12	0.040"	19	0.855	0.2170	0.2170	0.1531	0.2170	0.2170	0.6016	76.4	61.1	50.9	43.6	38.2	33.9	30.6	27.5	23.1	13.0
16	24	50	1.36	0.1020	0.0855	0.0682	0.0451	0.0616	0.0480	208.6	166.9	133.3	98.0	75.0	59.3	48.0	39.7	33.3	18.8
16	22	50	1.71	0.1323	0.1120	0.0825	0.0609	0.0816	0.0623	330.0	249.2	173.1	127.1	97.3	76.9	62.3	51.5	43.3	24.3
16	0.032"	19	0.640	0.1420	0.1420	0.0961	0.1420	0.1420	0.4760	37.7	30.2	25.2	21.6	18.9	16.8	14.6	12.1	10.1	5.7
16	0.040"	19	0.780	0.1750	0.1750	0.1180	0.1750	0.1750	0.5830	57.3	45.8	38.2	32.7	28.6	25.5	22.9	19.9	16.7	9.4
18	24	50	1.28	0.0920	0.0769	0.0605	0.0400	0.0551	0.0426	185.5	148.4	118.3	86.9	66.6	52.6	42.6	35.2	29.6	16.6
18	22	50	1.61	0.1200	0.1009	0.0798	0.0540	0.0731	0.0553	293.2	221.2	153.6	112.9	86.4	68.3	55.3	45.7	38.4	21.6
18	0.032"	19	0.620	0.1290	0.1290	0.0859	0.1290	0.1290	0.4700	33.6	26.9	22.4	19.2	16.8	14.9	13.5	11.4	9.6	5.4
18	0.040"	19	0.760	0.1590	0.1590	0.1060	0.1590	0.1590	0.5740	50.9	40.7	33.9	29.1	25.5	22.6	20.4	17.4	14.6	8.2

- Allowable loads for Steel panels are calculated in accordance with 2020 AISI S100 specifications considering bending, shear, combined bending and shear and deflection. Allowable load considers a 3 or more equal span condition.
- The Versa-Span Panel when installed as a three-span condition with spans of 5 ft. on-center for Steel and 3.0 ft. on-center for Aluminum are capable of withstanding the minimum uniform distributed load of 20 psf (0.958 kPa) noted in Table 1607.1 of the IBC and a minimum concentrated load of 300 lbf (1.33 kN).
- When panels are installed over solid or closely fitted deck sheathing, the capacity is limited to the capacity of the underlying sheathing.

PANEL CLIPS

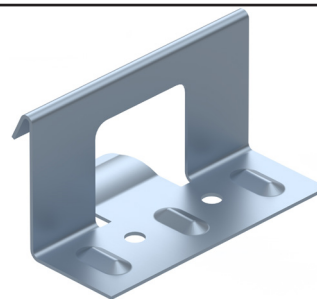
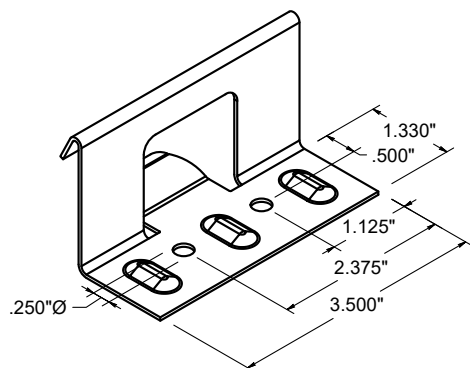
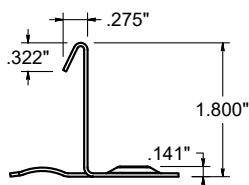

Clip spacing

Panel clip spacing is based on structural design loads, engineered spanning capability of the panels and substrate.

Fasteners

All fasteners going into steel or plywood must extend at least 3 full threads beyond the material. When attaching to dimensional lumber, 1" embedment is required.

OSB: #10 Burr Buster

Plywood and Dimensional Lumber: #10 Screw

16GA (or less) Steel deck: #10 or #12 Screw with DP-1

STANDARD CLIP: for U.S. rated and engineered solid deck applications.
Accommodates for unlimited thermal movement in both directions.
Clips are fabricated from Grade 50 G90 base steel, 18 ga.

UL580 & UL1897 SOLID DECK - NEGATIVE LOAD CHART

Width, in. Gauge Yield ksi Weight psf				SECTION PROPERTIES						ALLOWABLE UNIFORM LOADS, psf For various clip spacings (i.e. span values)					
				Top in Compression			Bottom in Compression			Negative Load					
				I_{xx} in ⁴ /ft.	I_{xx} (eff) in ⁴ /ft.	S_{xx} in ³ /ft.	I_{xx} in ⁴ /ft.	I_{xx} (eff) in ⁴ /ft.	S_{xx} in ³ /ft.	8"	1'	1.5'	2'	2.5'	3'
14	24	50	1.38	0.1160	0.0969	0.0809	0.0500	0.0691	0.0553	138.5	130.0	117.1	104.3	91.4	78.5
14	22	50	1.66	0.1380	0.1161	0.0964	0.0626	0.0845	0.0673	138.5	130.0	117.1	104.3	91.4	78.5
14	20	33	2.03	0.1663	0.1444	0.1162	0.0907	0.1126	0.0897	138.5	130.0	117.1	104.3	91.4	78.5
16	24	50	1.32	0.1020	0.0855	0.0682	0.0451	0.0616	0.0480	116.0	109.6	100.0	90.3	80.7	71.0
16	22	50	1.60	0.1323	0.1116	0.0825	0.0609	0.0816	0.0623	116.0	109.6	100.0	90.3	80.7	71.0
16	20	33	1.95	0.1492	0.1292	0.1027	0.0803	0.1002	0.0786	116.0	109.6	100.0	90.3	80.7	71.0
18	24	50	1.28	0.0920	0.0769	0.0605	0.0400	0.0551	0.0426	101.0	95.7	87.6	79.6	71.5	63.5
18	22	50	1.55	0.1200	0.1009	0.0798	0.0540	0.0731	0.0553	101.0	95.7	87.6	79.6	71.5	63.5
18	20	33	2.46	0.1740	0.1537	0.1179	0.1040	0.1243	0.0953	101.0	95.7	87.6	79.6	71.5	63.5

- Charted Load/Span values are based on UL580/UL1897 testing protocol.
- Charted Allowable Uniform Loads are based on the Ultimate Uniform Load (per UL580/UL1897 testing) divided by 2.00 Factor-of-Safety.
- Panel tested over plywood (15/32" min. APA rated) substrate
- Charted allowable uniform loads cannot be increased bt 1/3.
- Panel tested using 3.5" long X 18GA. Steel fixed clip.
- Clip attached to plywood substrate with two (2) #10-13 low -profile pancake head screws.

UL580 & UL1897 SOLID DECK - POSITIVE LOAD CHART

Width, in. Gauge Yield ksi Weight psf				SECTION PROPERTIES						ALLOWABLE UNIFORM LOADS, psf For various clip spacings (i.e. span values)								
				Top in Compression			Bottom in Compression			Positive Load								
				I_{xx} in ⁴ /ft.	I_{xx} (eff) in ⁴ /ft.	S_{xx} in ³ /ft.	I_{xx} in ⁴ /ft.	I_{xx} (eff) in ⁴ /ft.	S_{xx} in ³ /ft.	2'	2.5'	3'	3.5'	4'	4.5'	5'	5.5'	6'
12	24	50	1.47	0.1299	0.1095	0.0907	0.0596	0.0800	0.0638	278.2	222.6	177.2	130.2	99.7	78.8	63.8	52.7	44.3
12	22	50	1.88	0.1645	0.1401	0.1157	0.0804	0.1048	0.0827	440.0	330.8	229.7	168.8	129.2	102.1	82.7	68.4	57.4
12	20	33	2.13	0.1860	0.1628	0.1337	0.1060	0.1292	0.1046	435.8	278.9	193.7	142.3	109.0	86.1	69.7	57.6	48.4
12	0.032"	19	0.684	0.1770	0.1770	0.1245	0.1770	0.1770	0.4904	50.5	40.4	33.6	28.8	25.2	22.4	20.2		
12	0.040"	19	0.855	0.2170	0.2170	0.1531	0.2170	0.2170	0.6016	76.4	61.1	50.9	43.6	38.2	33.9	30.6	27.5	23.1
14	24	50	1.38	0.1160	0.0969	0.0809	0.0500	0.0691	0.0553	238.2	190.6	153.6	112.9	86.4	68.3	55.3	45.7	38.4
14	22	50	1.66	0.1380	0.1161	0.0964	0.0626	0.0845	0.0673	376.8	269.2	186.9	137.4	105.2	83.1	67.3	55.6	46.7
14	20	33	2.03	0.1663	0.1444	0.1162	0.0907	0.1126	0.0897	373.8	239.2	166.1	122.0	93.4	73.8	59.8	49.4	41.5
14	0.032"	19	0.651	0.1540	0.1540	0.1080	0.1540	0.1540	0.4790	43.2	34.6	28.8	24.7	21.6				
14	0.040"	19	0.815	0.1900	0.1900	0.1330	0.1900	0.1900	0.5880	65.5	52.4	43.6	37.4	32.7	29.1	26.2	22.7	
16	24	50	1.32	0.1020	0.0855	0.0682	0.0451	0.0616	0.0480	208.6	166.9	133.3	98.0	75.0	59.3	48.0	39.7	33.3
16	22	50	1.60	0.1323	0.1116	0.0825	0.0609	0.0816	0.0623	330.0	249.2	173.1	127.1	97.3	76.9	62.3	51.5	43.3
16	20	33	1.95	0.1492	0.1292	0.1027	0.0803	0.1002	0.0786	327.5	209.6	145.6	106.9	81.9	64.7	52.4	43.3	36.4
16	0.032"	19	0.627	0.1390	0.1390	0.0958	0.1390	0.1390	0.4740	37.7	30.2	25.2	21.6					
16	0.040"	19	0.784	0.1750	0.1750	0.1180	0.1750	0.1750	0.5830	57.3	45.8	38.2	32.7	28.6	25.5	22.9		
18	24	50	1.28	0.0920	0.0769	0.0605	0.0400	0.0551	0.0426	185.5	148.4	118.3	86.9	66.6	52.6	42.6	35.2	29.6
18	22	50	1.55	0.1200	0.1009	0.0798	0.0540	0.0731	0.0553	293.2	221.2	153.6	112.9	86.4	68.3	55.3	45.7	38.4
18	20	33	2.46	0.1740	0.1537	0.1179	0.1040	0.1243	0.0953	295.5	236.4	176.5	129.7	99.3	78.4	63.5	52.5	44.1
18	0.032"	19	0.608	0.1270	0.1270	0.0857	0.1270	0.1270	0.4670	33.6	26.9	22.4						
18	0.040"	19	0.760	0.1590	0.1590	0.1060	0.1590	0.1590	0.5740	50.9	40.7	33.9	29.1	25.5	22.6	20.4		

- Allowable loads for Steel panels are calculated in accordance with 2020 AISI S100 specifications considering bending, shear, combined bending and shear and deflection. Allowable load considers a 3 or more equal span condition.
- Allowable loads does not address panel weight, fasteners, connection strength or support material.
- The Versa-Span Panel when installed as a three-span condition with spans of 5 ft. on-center for Steel and 2.0 ft. on-center for Aluminum are capable of withstanding the minimum uniform distributed load of 20 psf (0.958 kPa) noted in Table 1607.1 of the IBC and a minimum concentrated load of 300 lbf (1.33 kN).
- When panels are installed over solid or closely fitted deck sheathing, the capacity is limited to the capacity of the underlying sheathing.