



# Through Fastener Installation Guide



**Tuff Rib ~ T-3™ ~ GR-7™ ~ GR-5™ ~ HR-34™ ~  
PBR ~ Marion "R" Panel™ ~ Max Corr™ ~  
2-1/2" Corrugated & Classic 7/8" Corrugated™  
Classic V-Rib™**



- 4
- Notes To Designer/Installer..... 5-7
- Taylor Delivery Fleet.....8
- Delivery & Will Call/Loading..... 9
- Tools/Equipment.....10
- Fasteners.....11-12
- Panel Profile Chart.....13
- Flashing Applications.....14-41
- Flashings.....42-71
- Accessories.....72-75
- Order Forms.....76-77

## Flashing Applications (cont):

- Gable Detail..... 20
- Gable Step Detail..... 21
- Peak Flashing (R.E.C.) Detail ..... 22
- Sidewall Detail ..... 23
- Endwall Detail ..... 24
- Alternate Endwall Detail ..... 25
- Flashing Lap Detail..... 26
- Short Lap Detail ..... 27
- Long Lap Detail ..... 28
- Base & C-Flashing Detail..... 29
- Inside/Outside Corner Detail..... 30-33
- Mini Corner Detail.....34
- Pitch Change Detail.....35-36
- Soffit Ridge Detail.....37
- Door Track Detail.....38
- Pan Flashing Detail..... 39
- Prow Detail.....40
- Jamb Detail.....41

## Flashing Applications:

- Standard Ridge Detail.....14
- Vented Ridge Detail.....15
- LT Ridge Detail.....16
- W-Valley Detail.....17
- Eave Detail .....18
- Eave Step Detail..... 19

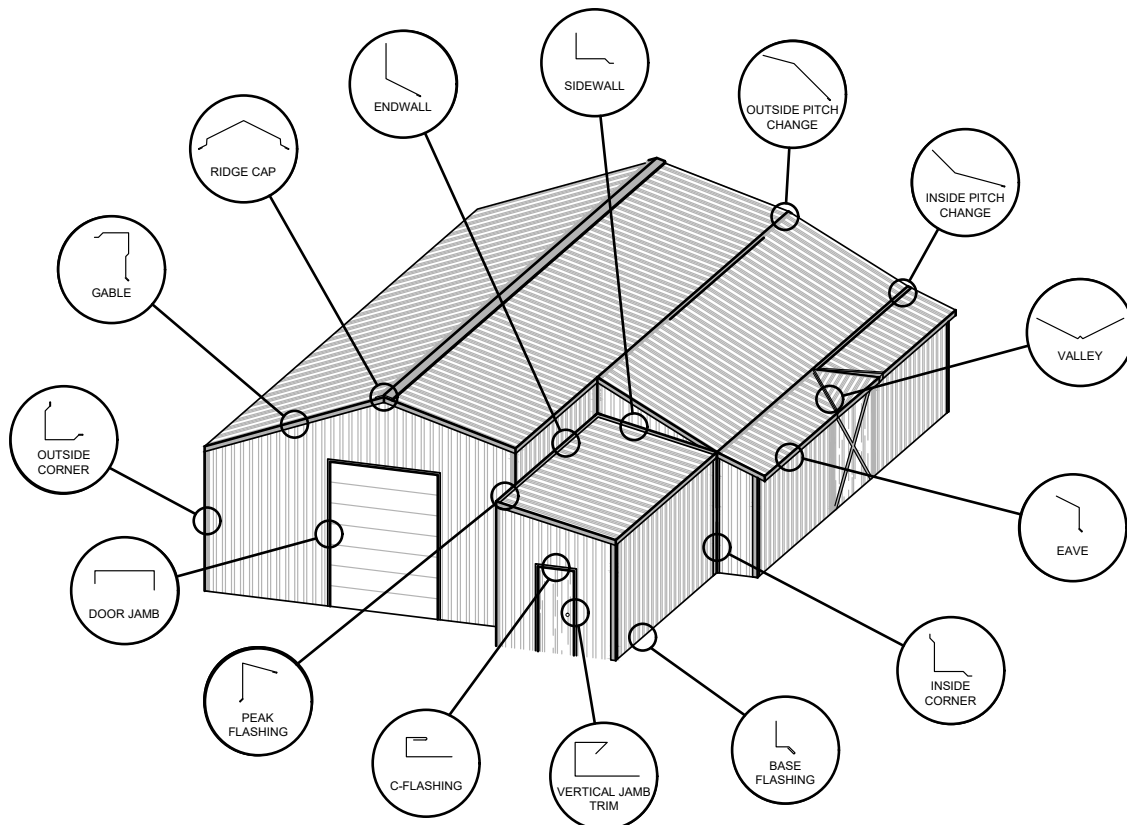

**Taylor Metal Products** is a locally owned and operated business. Since 1985 we have combined the most rigorous quality standards and exceptional service to deliver what is widely stated as the most time-tested and valued roof and wall system in the industry. At Taylor Metal we listen to our customers, this is how we have become the supplier of choice to many in the industry. Our entire team is always committed to taking whatever steps necessary to meet your needs.

We have an exceptionally skilled and motivated team. Our employees, some of whom have been with Taylor for more than a dozen years, take great pride in their work and it shows in each and every order we produce.

The team at Taylor goes far beyond just taking your order. We will work with all parties involved in the building process to determine the most appropriate materials, flashing designs, and installation procedures to ensure you have a building solution to last a lifetime.

We offer high-quality SMP and top of the line Kynar 500® paint systems, with "Cool Color" technology and a complete line of standard flashing and accessories. In addition, we offer affordable, custom-made flashings for all your project needs.

No attempt is made to provide installation details for every application or possible use. Conformity to local building codes, details for specific applications, and use of safety and health procedures is the sole responsibility of the installer. Taylor Metal Products, assumes no liability for the improper installation of the product nor for any personal injury or property damage that may occur with the product's use.

We invite you to call us today at **800-574-1388** or **503-581-8338** for product or technical information.

## Notes to Designer/Installer

**Taylor Metal Products** is providing the following details as an aid in design. The details in this guide are not inclusive to all design situations. The designer/installer is responsible for modifications and should take into consideration all aspects of the project including climate conditions, such as, snow and wind, as well as, building code requirements, building design, building usage and maintenance requirements.

Installation should be performed only by qualified installers familiar with metal roofing systems and industry standards.

The Standard gauge for all products in this guide is 24 gauge and the standard finish is Kynar 500®. We recommend specifying all flashings be the same gauge, color, and finish as the panels to ensure long-term durability and color match.

### **Substrates**

Details in the manual are all shown over solid substrate. Panels can be used over spaced purlins. For solid substrate, **Taylor Metal Products** recommends 15/32" plywood or 22 ga. metal deck.

### **Underlayment**

Minimum underlayment requirements are 30 lb. ASTM rated felt, a synthetic underlayment with Class A and ASTM UV protection technology or a high temperature self-adhering rubberized membrane. When choosing the underlayment, consider the roof slope, roof design, roof panel, and the climate.

### **Ventilation/Insulation**

It is the responsibility of the designer to determine the material types needed to control condensation and to insulate and ventilate the roof system. Applications over rigid insulation may require blocking for solid attachment and framing the perimeter for installation of perimeter flashings.

### **Oil Canning**

All light gauge metals can display waviness often referred to as "oil canning." Oil canning is caused by a variety of conditions, including steel mill tolerances, substrate variations or unevenness and roofing underlayments. Oil canning is an inherent characteristic of metal roofing, not a defect and is not a cause for material rejection.

### **Thermal Movement**

The Panels and the flashings must be allowed to expand and contract, especially with longer length panels.

## **Snow Design**

The following details do not address all conditions for snow environments. Consult with the designers, engineers, and others for acceptable details to accommodate your project and climate conditions. When possible gutters, valleys, pitch changes or other penetrations should be minimized in snow areas.

All roof penetrations should be located as close to the ridge or “pin point” top of roof. Snow country requires special designs for valleys to accommodate accumulation of snow and ice from uphill panels. Roof design should be considered in snow areas. Roof design should help resist the melting and freezing of snow and ice.

A fit for purpose roof design has the greatest impact on maintaining a damage free roof system in snow areas. Please contact a Taylor Metal Products representative for assistance in detail designs and appropriate panel selection for specific climate and building conditions.

## **Handling & Storage**

Handle materials with care when off-loading or moving materials to avoid damage to panels or flashings. Long panels may require two or more pick-up points, properly spaced to avoid damaging panels. Plan ahead; contact **Taylor Metal Products** for recommendations on handling/hoisting long panels.

Store the panels, flashings and accessories in a dry, well ventilated area, off the ground. If covering, allow ventilation around panels. Elevate one end of bundle to allow drainage of wet materials.

Wear clean, soft-soled shoes when walking on roofing panels to avoid damage to the painted finish.

Take care that sand, gravel, dirt, etc. sticking to your shoes is not carried onto the roof, scratching or otherwise damaging the finish on the roofing material. Walking on asphalt impregnated felt paper, especially on a hot day, can cause the asphalt to stick to your shoes and be tracked on to the roofing material.

Take care when painting to avoid getting over spray on the roofing material. Remember that wind can carry paint particles some distance. Over spray can cause the finish of the roofing material to look dull and may void your warranty.

## **Safety**

Secure materials, especially when leaving the site, on the ground or roof to prevent winds from moving the materials. Wind-blown materials may cause damage to the material, property or persons.

Always use proper safety equipment and attire to minimize risk of cuts or other injuries.

Do not walk on panels that have not been completely installed.

Do not walk on major ribs of panels.

Metal roofs that are wet or dusty can be extremely slippery. Wear soft soled shoes and a safety harness to minimize risk of falling.

Avoid installing metal panels in windy conditions.

Safety considerations are the responsibility of the installer and his crew. Be sure to **use common sense** and generally accepted safety practices when installing roofing materials.



## Delivery Fleet

Taylor Metal Products prides itself with quick lead times delivered with our fleet of semi trucks. Our fleet of trucks are owned and operated by TMP. All of our drivers are Taylor Metal Products employees, so when your truck rolls in to deliver, you are dealing with Taylor Metal Products.

Expect consistent and exceptional service with short lead times. The inhouse fleet allows for efficient and cost-effective delivery.



Mounted on the rear of our truck's trailer, the trailer-mounted "Piggy-Back" forklift will accompany you right to your place of use, opening up unprecedented possibilities in terms of transportation. It can travel sideways, carrying panels up to 40' long, allowing delivery in locations that would typically be considered impossible to reach.

Save time and effort while avoiding potential loading and transport issues; have experienced TMP personnel deliver and unload your order.



## Delivery

We will make every attempt to deliver material to the desired location. We may be unable to gain access on tight corners or steep terrain. If the site is deemed inaccessible by our driver, the customer may choose an alternate delivery site within a reasonable proximity. If we are unable to make the alternate delivery, additional charges may be assessed.

The customer is responsible for:

- Determining adequate access for delivery ahead of time.
- Meeting the delivery at the agreed upon time.
- Providing adequate resources (1-4 people as needed) for off loading materials. **A charge of \$100 per hour may be added for deliveries that go beyond their allotted time.**
- Checking the shipment at the time of delivery.
- Verifying material quantities against the shipping list.
- Noting any damage or discrepancies upon the paper work at the time of delivery and notifying Taylor Metal Products within 48 hours of delivery.

Delivery times are usually scheduled one day in advance. Taylor Metal Products will make every effort to make the delivery at the scheduled time. Please be aware that there may be conditions beyond our control such as traffic, mechanical failures, road closures, etc. which may affect our schedule. If a delay is expected, you will be notified in advance of delivery.

**Standard Packaging:** Standard packaging is included in the panel price and is designed to insure your products are delivered free from damage. All roofing and siding orders are packaged for protection with steel cover sheets and banded with slotted band boards. Maximum weight per skid is 5000 lbs. for forklift unload.

**Long Length Packaging:** On orders 24' or longer, pallets will be used to ensure safe loading and unloading of panels. A refundable deposit of \$135.00 per 20' pallet or \$410.00 for a 30' pallet will be charged. Deposit will be refunded when pallet returned in good condition.

**Additional Skid Packaging:** When customer requests less than maximum weight per skid, additional packaging charges of \$1.25 per lineal foot of skid will be charged.

## Will Call/Loading

Flatbed trailers and trucks are best suited to transport metal roofing materials. These can be loaded from the side with a forklift and tied down in a safe and secure manner.

We are not able to load materials onto vehicles and/or trailers which are not suitable or may be hazardous to load. Please be aware that if we find a vehicle to be inappropriate, we reserve the right to refuse to load your order.

Unacceptable examples include: boat trailers, vans, buses, motor homes, campers and box trailers. Pickup racks which do not have sufficient supports for the weight or are not long enough to support bundles are also unacceptable.

Taylor Metal Products is **not** responsible to tie down loads nor do we provide any tie down materials. Please bring tie downs to secure your load (string or twine are **not** acceptable for this purpose).

**Consider having your order delivered on one of our trucks with a piggy back forklift.**



## The following tools/safety equipment may be used for proper installation:

- Screw Gun: Clutch type, variable torque, cordless screw guns will give the best results.
  - Extra batteries
  - Bit holder - magnetic
  - #2 square drive bits or philips drive bits (for panel screws)
  - 1/4" Hex head - magnetic - bit driver (for woodfast flashing screws)
  - 1/8" drill bit (for rivets & pre-drilling fastener holes)
  - Belt & holster (keeps all the above tools safely on your hip)

### Cutting Tools:

- Cutters/Offset (curved jaw) left & right (for precision cutting, long cuts)
- Snips (straight jaw) left & right (for short cuts & circular cuts)
- Electric Shears (aids in long panel rips)

### **CAUTION: POWER SAWS MAY CAUSE PANEL DAMAGE!**

TMP recommends cutting panels and flashings with tin snips or shears.





We do **NOT** recommend the use of saw blades or abrasive wheels - use may void warranties and reduce longevity, especially in marine environments.

### Other Tools:

- DeBurring Tool
- Hole Punch (for pre-punching holes in metal)
- Rubber Mallet - SoftType (for adjusting panels & flashings)
- Quick Square, Framing Square & Bevel Square (aids in squaring flashings & panels)
- Duck Bill Vise Grips/Pliers (for various bending)
- Upender Tools (used for panel-prep, available at TMP)
- Tape Measures
- Rivet Tool (for riveting flashings)
- Marking pen or grease pencil
- Chalk Line (for marking long panel rips and to align panels)
- Protective gloves to protect hands
- Cotton gloves for working with copper (to protect against fingerprints on finish)
- Ear plugs
- Safety harness kit

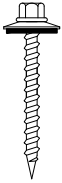
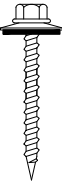
**WARNING** : Filings, debris and metal chips must be wiped off panels each day to avoid corroding the panels and causing rust specks or stains. Water can cause non-finished metal shaving to bind to panels after rust develops, damaging panels. Failure to properly install panels and remove debris may void the warranty.

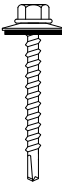
**TMP recommends the following fasteners:**

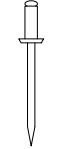
FASTENER	DESCRIPTION	USE
	<p><b>Woodfast Screw</b> #10 x 1", 1-1/2" 1/4" Hex Head Color Matched</p>	<p>#10 Woodfast screws are used to attach panel to dimensional lumber.</p>
	<p><b>Woodfast Screw</b> #14 x 1", 1-1/2" 5/16" Hex Head Color Matched</p>	<p>#14 Woodfast screws are used to attach panel to plywood/ OSB.</p>
	<p><b>Stitch Screw</b> #12 x 3/4" 1/4" Hex Head Color Matched</p>	<p>Stitch Screws are used to attach metal to metal such as lap joints, trim to trim, trim to panel and side lap attachment. They can be used interchangeably with rivits.</p>
	<p><b>Tek Screw</b> #12 x 1", 1-1/2" 5/16" Hex Head</p>	<p>Tek Screws are used for attaching panels to metal purlins.</p>
	<p><b>Tek Screw</b> #14 x 7/8" 5/16" Hex Head</p>	<p>Tek Screws are used for attaching panels to metal purlins.</p>
	<p><b>Rivets</b> #43 (1/8" x 1/8") Stainless Steel rivet Color Matched or non-painted.</p>	<p>Rivets are used to attach metal to metal such as lap joints, trim to trim, trim to panel and side lap attachment.</p>

\*Please note the illustrations (right) for proper fastener installation to ensure a weather-tight seal.

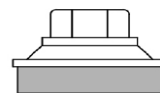

Under Tightened

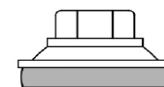

Correctly Tightened

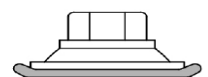

Over Tightened

## Notes:

- Fasteners should be installed according to the maximum recommended row spacing (see below.)
- Fasteners should be applied along each rib and to each purlin (see illustration below).
- In high wind areas the bottom row of panel fasteners should be applied with fasteners along both sides of each rib and on panel laps (see illustration below).
- When possible, lap panels away from prevailing wind direction.
- Stitch screws should be used on panel laps for all applications (12" o.c. maximum).
- Panel screws should be long enough to penetrate through the bottom of the plywood by 3/8".
- For dimensional lumber (2 x 6), panel screws should penetrate the lumber 1".
- All fasteners used for roof or wall applications should have EPDM sealing washers.
- Use a 2000 rpm depth-sensing nose piece screw gun to ensure proper fastener seal.
- Do not over drive or under drive fasteners (see illustration on page 8).
- Do not use #9 woodfast screws for attachment into plywood. #9 woodfast screws are designed to penetrate dimensional lumber. Use #14 fastener for plywood attachment.
- Clean off working area each day to remove metal particles left from drilling fasteners. These particles, when exposed to moisture, will form rust between metal particles and the panel.

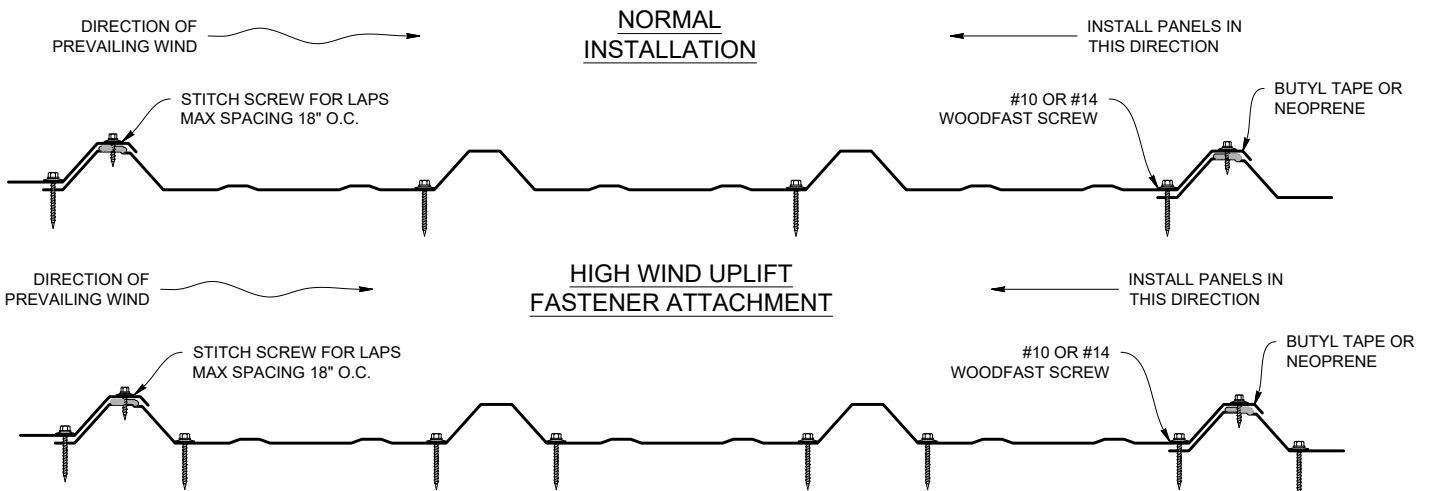

NOTE: EXTRA FASTENER PLACEMENT ON END OF PANEL AT EAVE ONLY

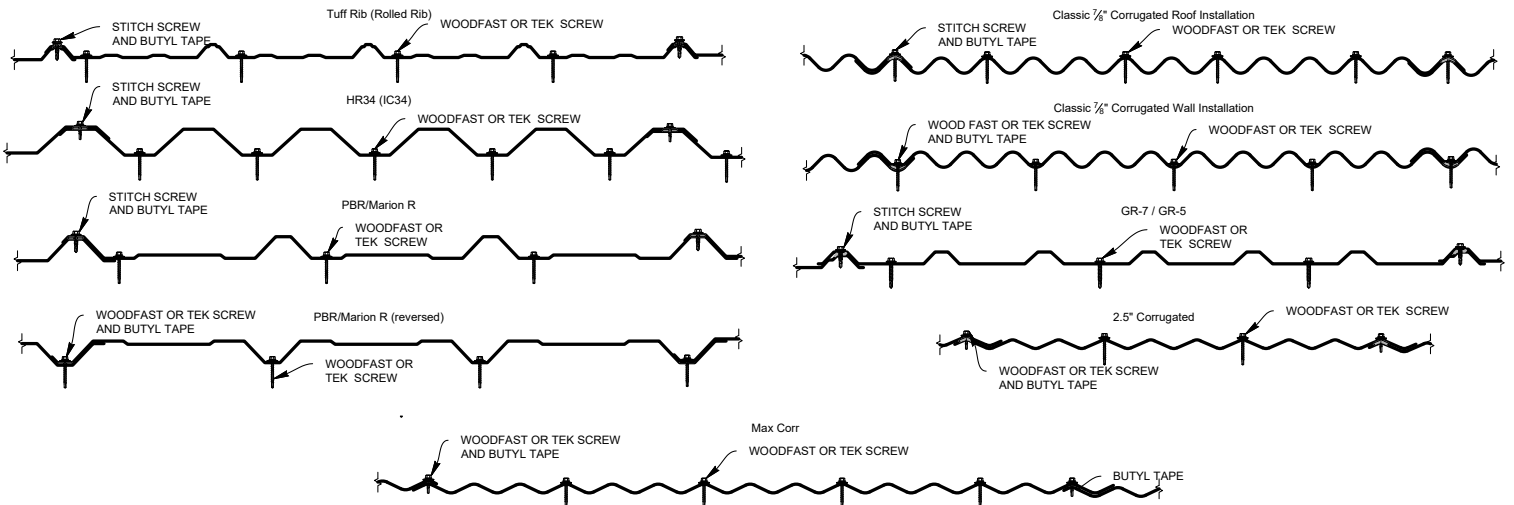

## TUFF RIB™

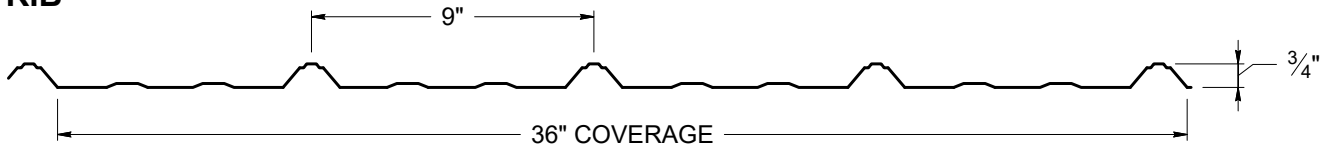

## T-3™



## GR-7™ - 36" GR-5 - 24"

NOTE: GR-5 ONLY AVAILABLE IN 29GA & 26GA, G-90 GALVANIZED OR AZ-50  
NOTE: GR-7 29GA HAS NO BEARING LEG

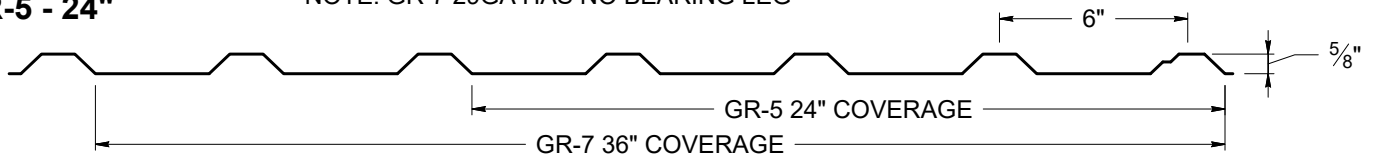

## PBR™



## MAX CORR™

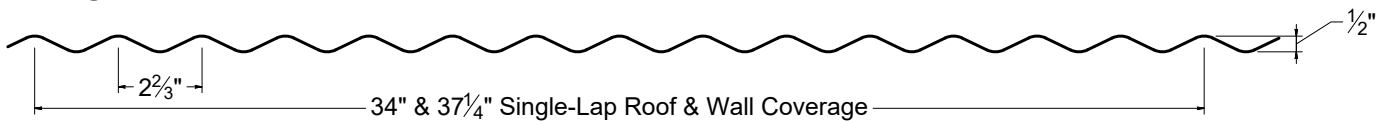

## 2-1/2" CORRUGATED™

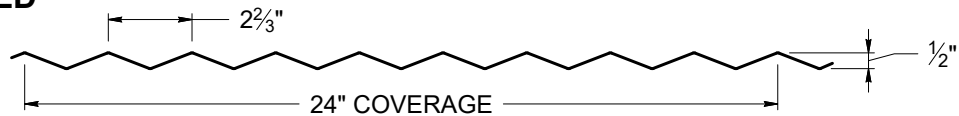

## CLASSIC 7/8" CORRUGATED™



## HR-34™

NOTE: STANDARD ROLLED SHOWN, REVERSE ROLLED AVAILABLE  
IF PAINTED, THIS SIDE

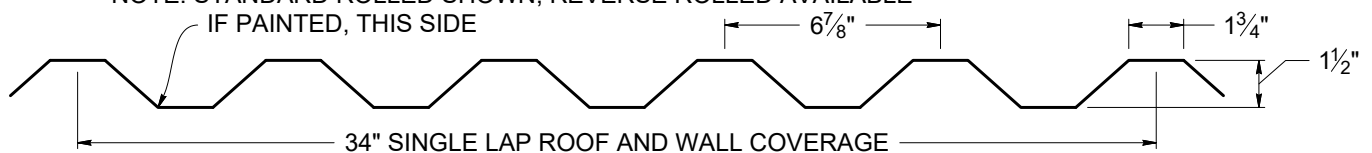

## CABIN RIDGE DETAIL

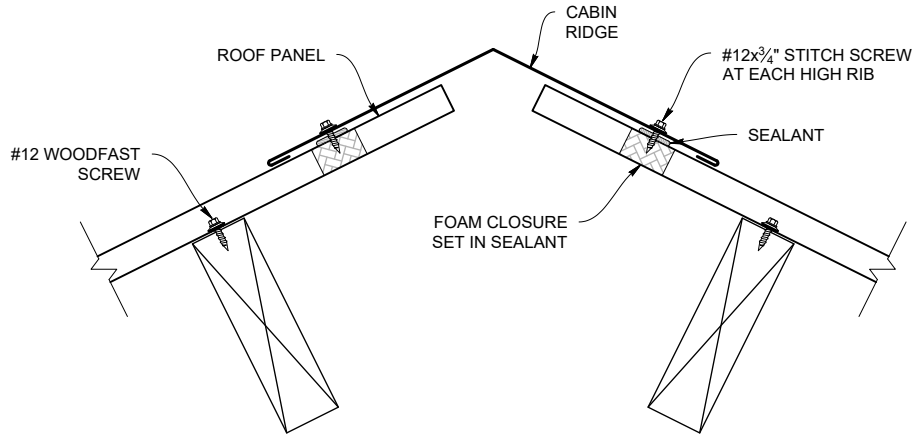

## PART SHOWN: (T3CR) CABIN RIDGE

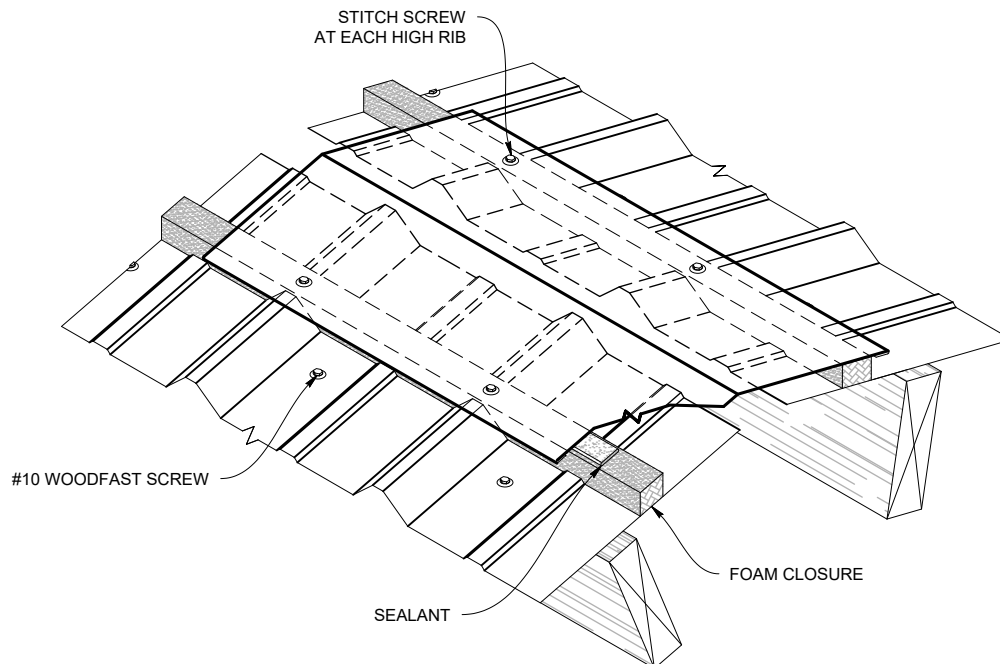
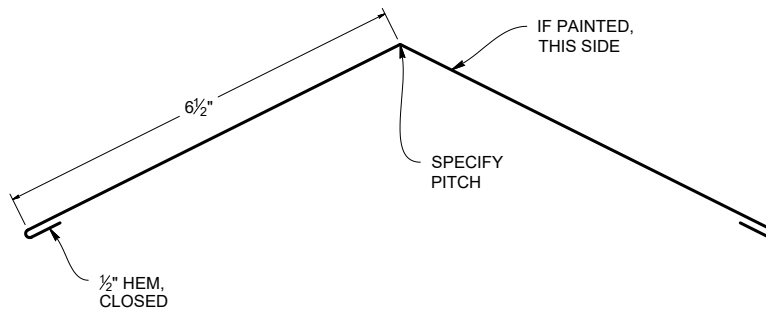

## VENTED RIDGE DETAIL

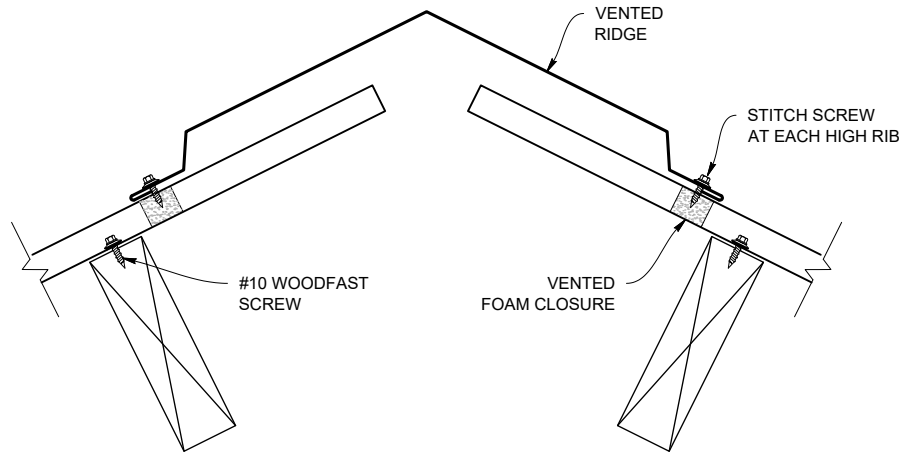

## PART SHOWN: (T3RVW) VENTED WIDE RIDGE

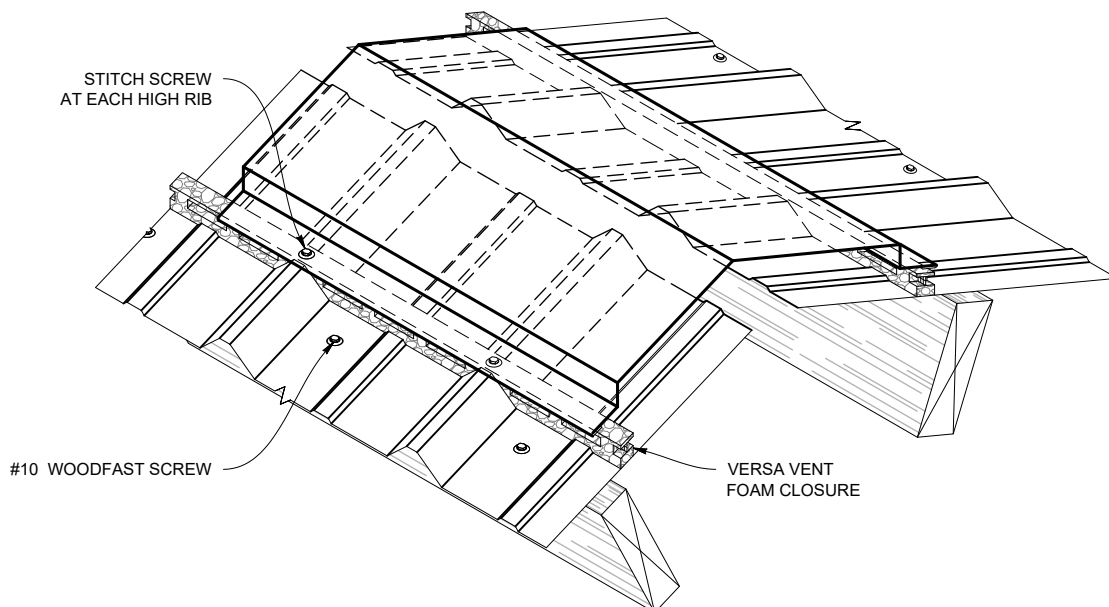
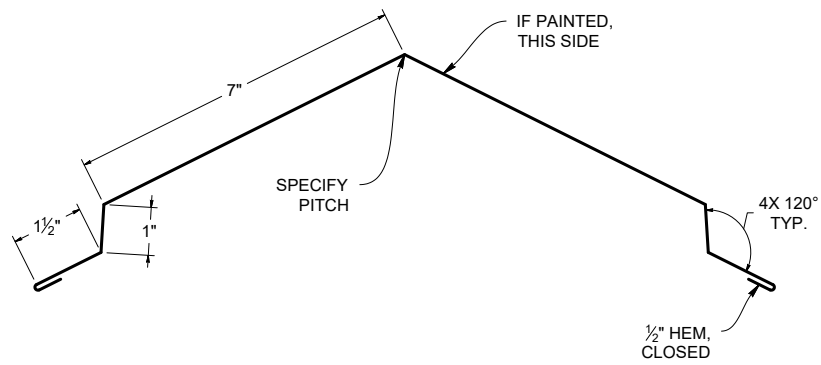

## LT RIDGE CAP DETAIL

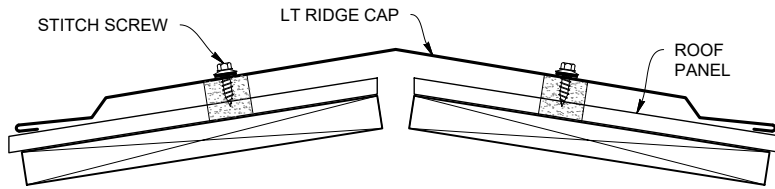

## PART SHOWN: (T3RLTH) HEMMED LT RIDGE CAP

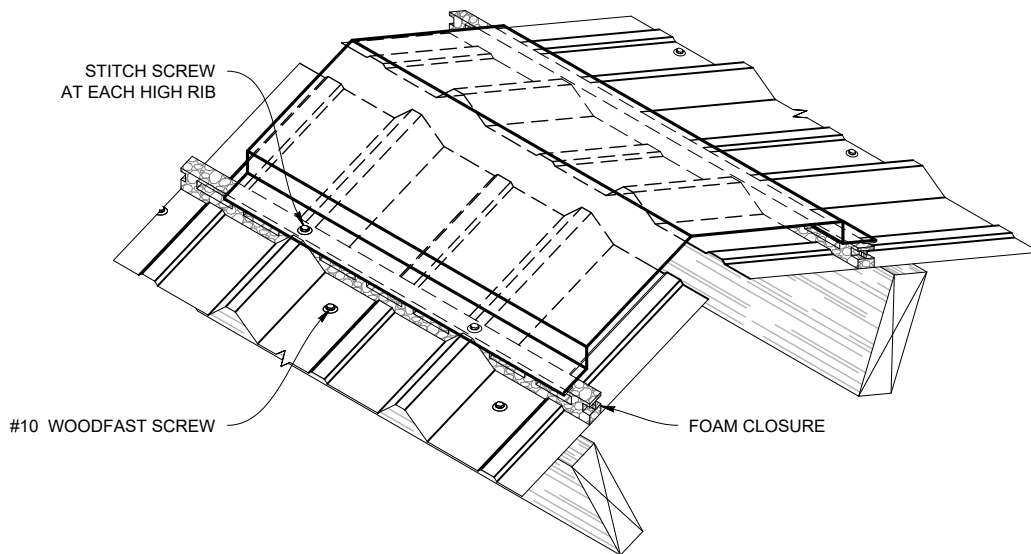
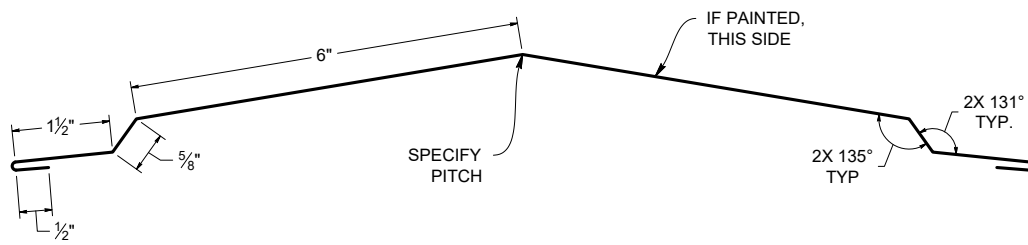

**W-VALLEY DETAIL**

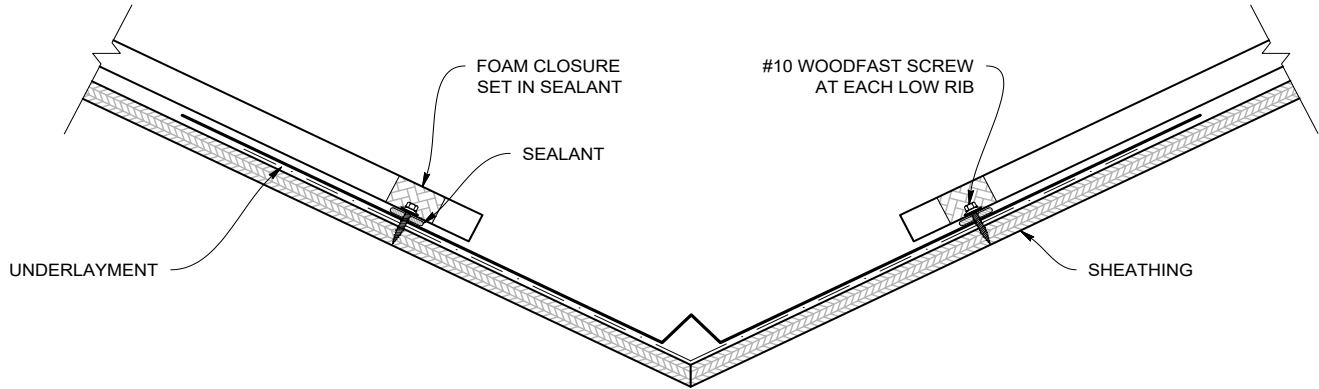

**PART SHOWN: (T3VF)  
28" W-VALLEY**

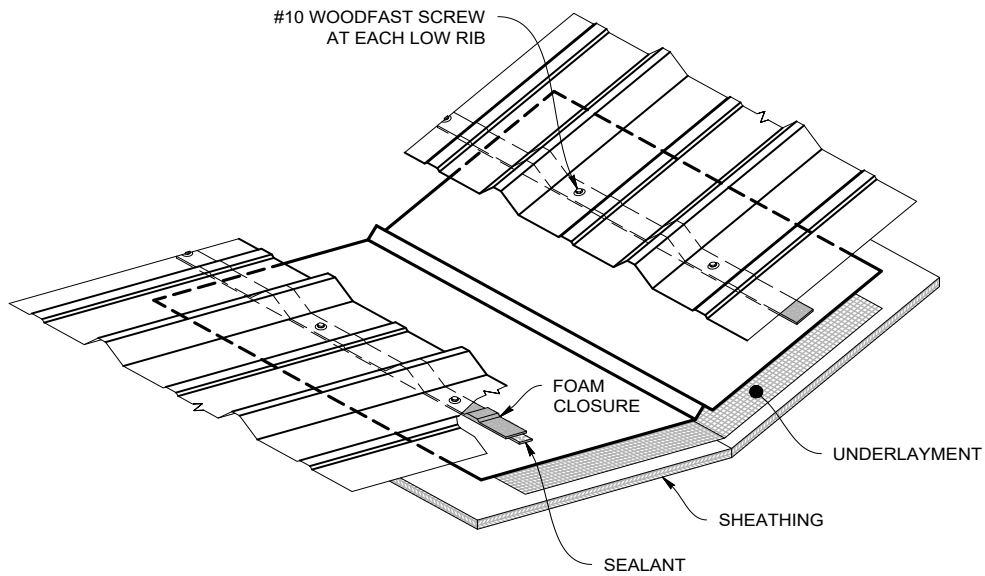
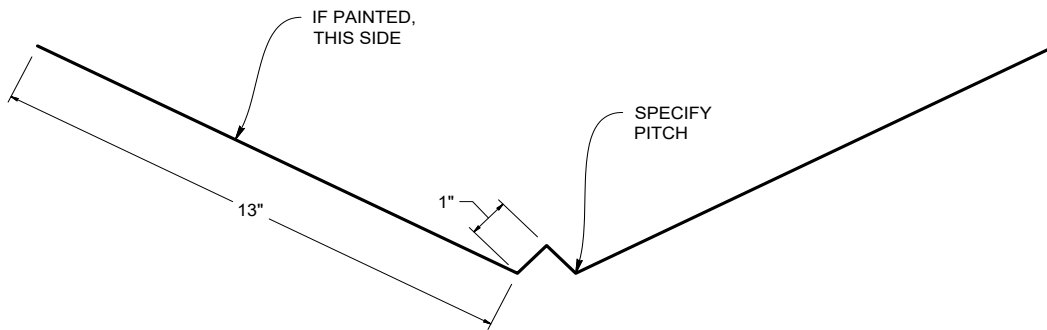

## EAVE DETAIL

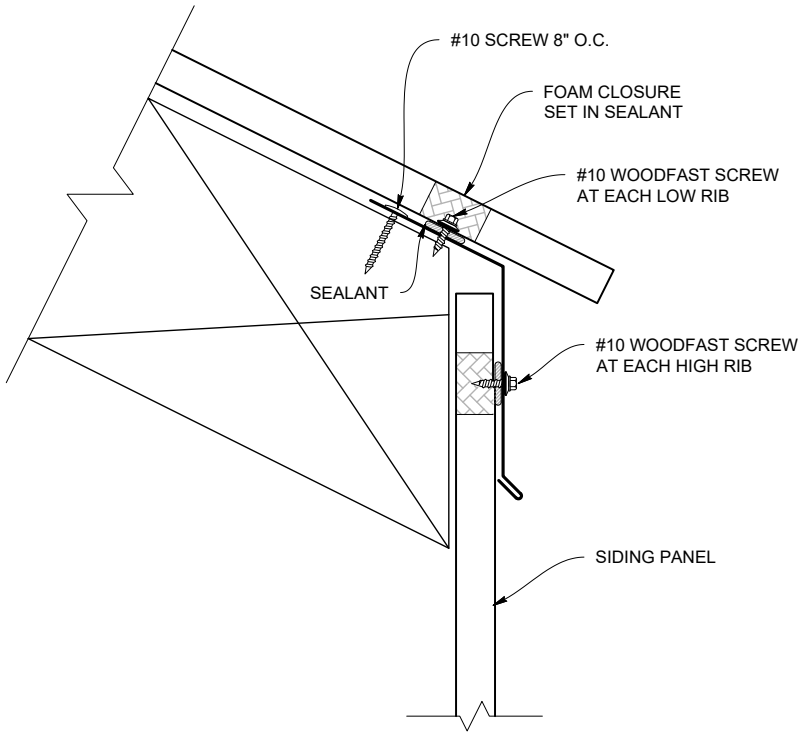

## PART SHOWN: (T3E4) 4" EAVE

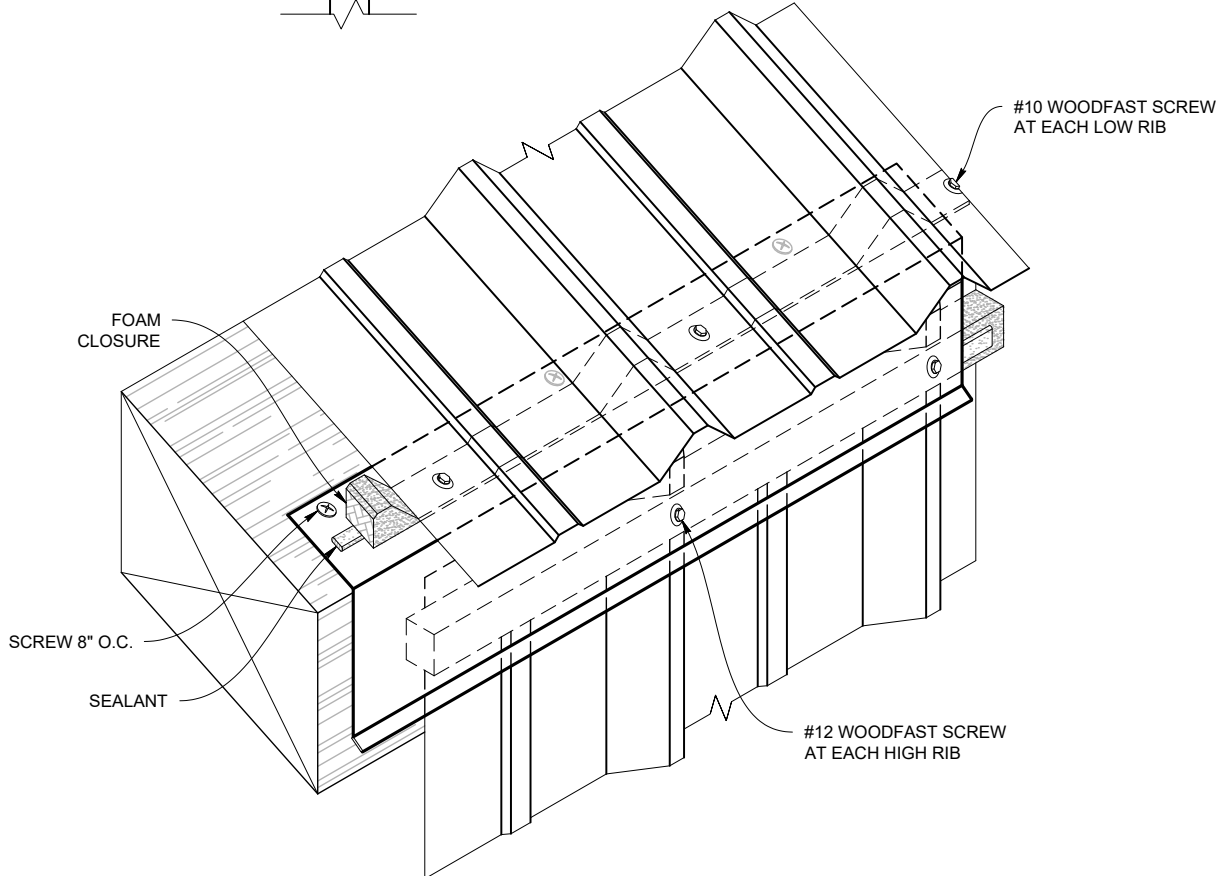
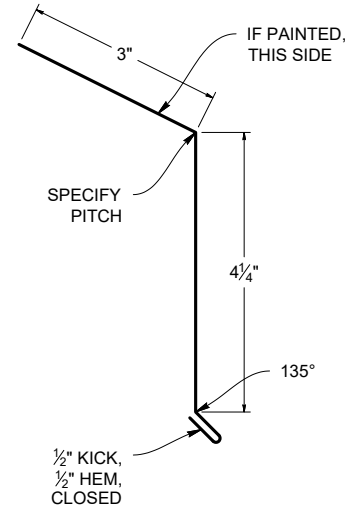

## EAVE DETAIL

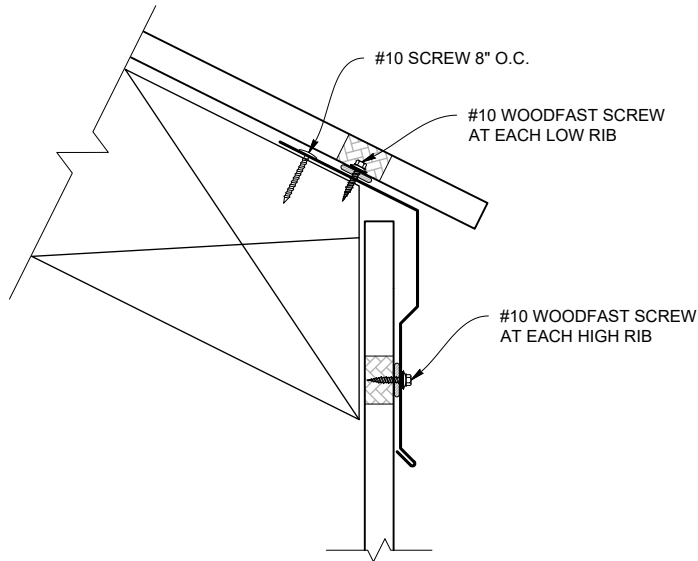

## PART SHOWN: (T3SE6) 6" STEP EAVE

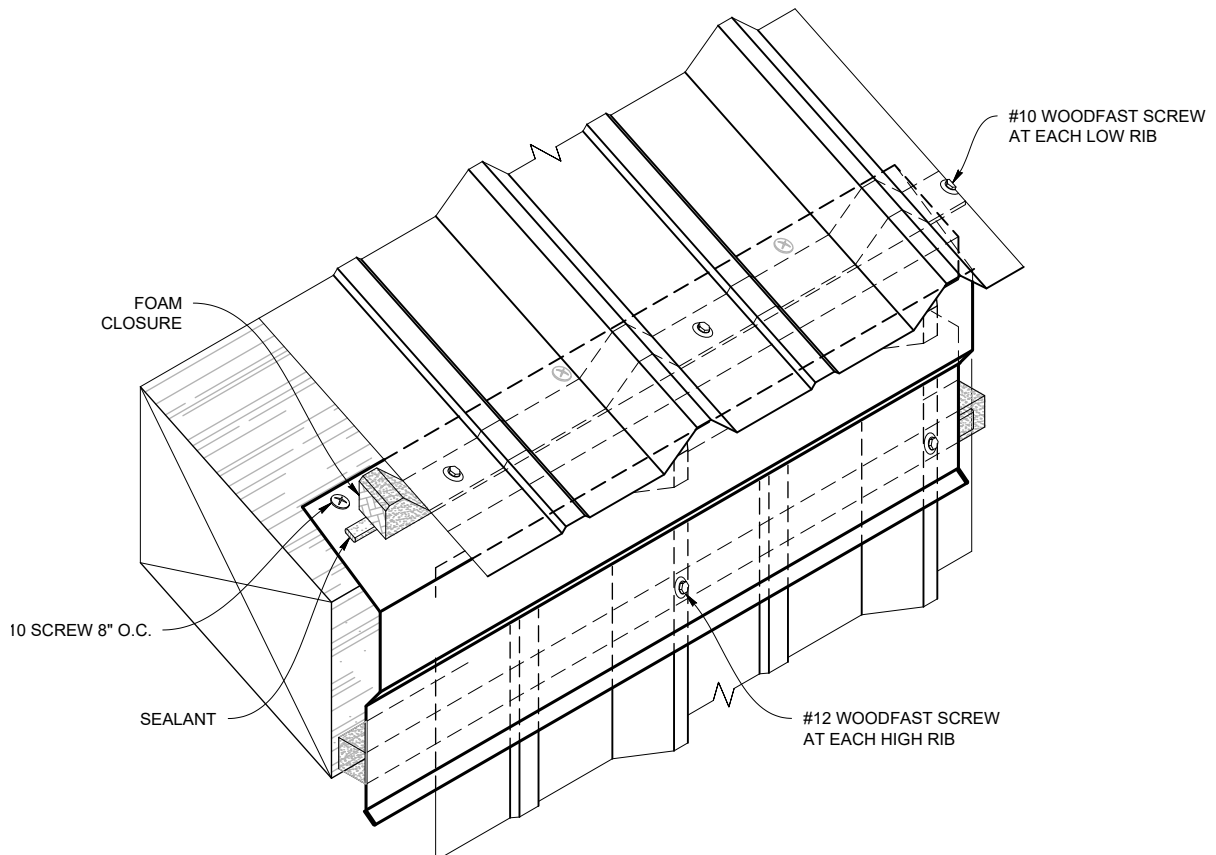
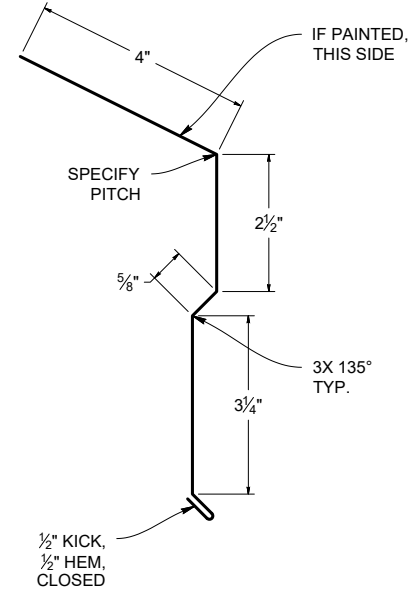

## GABLE DETAIL

**PART SHOWN: (T3GS)  
.75" STANDARD GABLE**

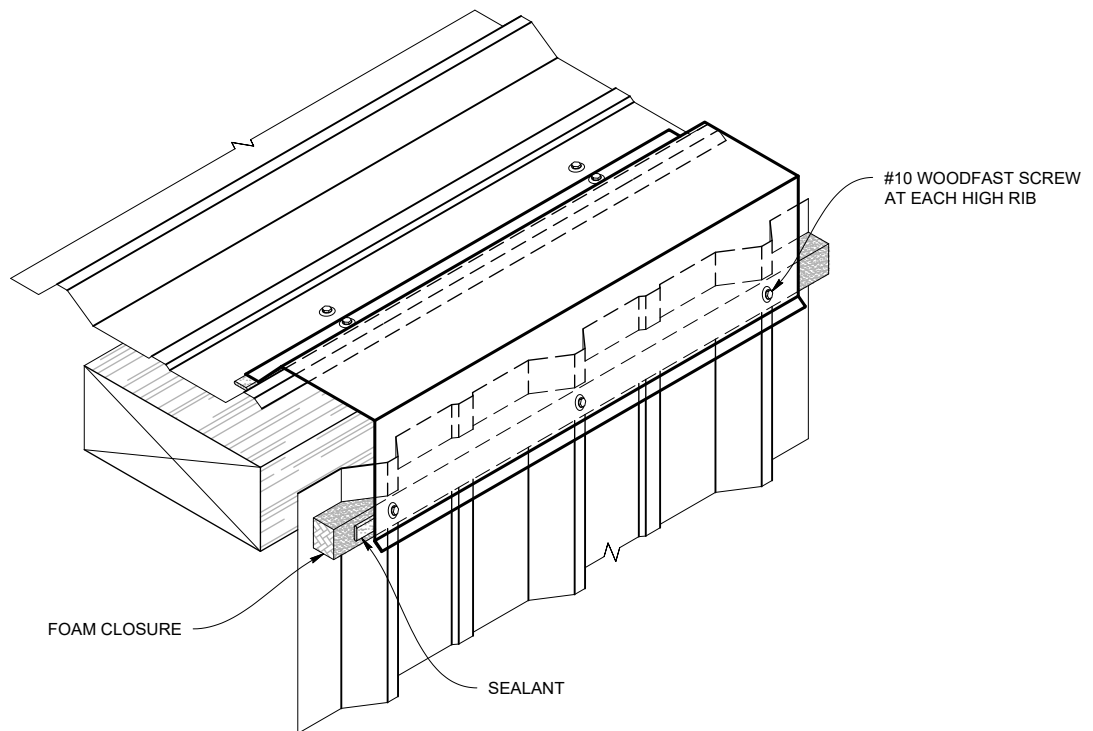
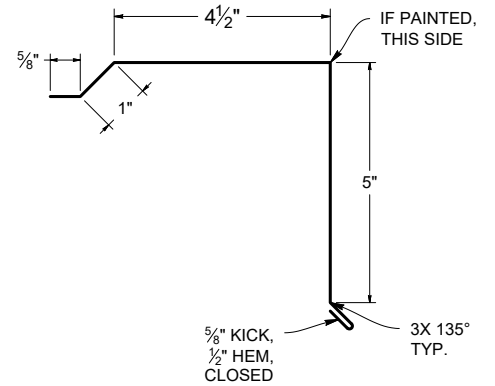
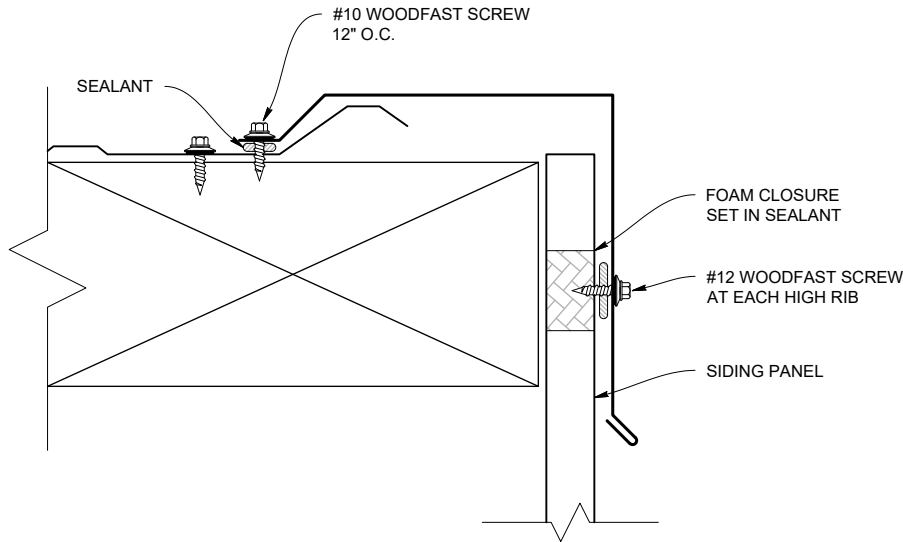

## STEP GABLE DETAIL

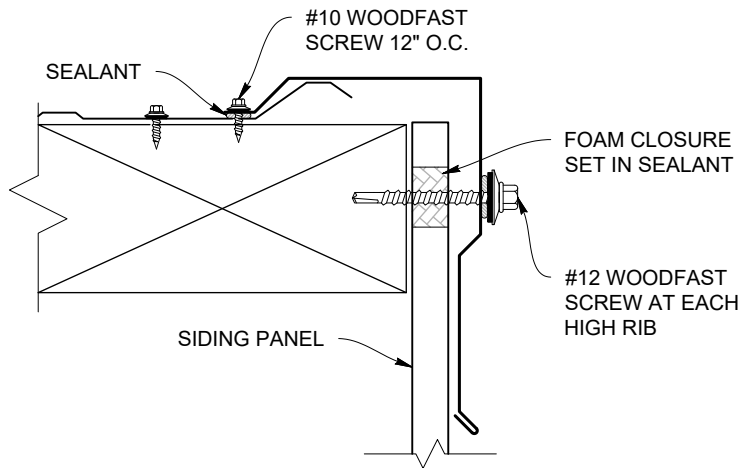

## PART SHOWN: (T3SG6) 2 x 6 STEP GABLE

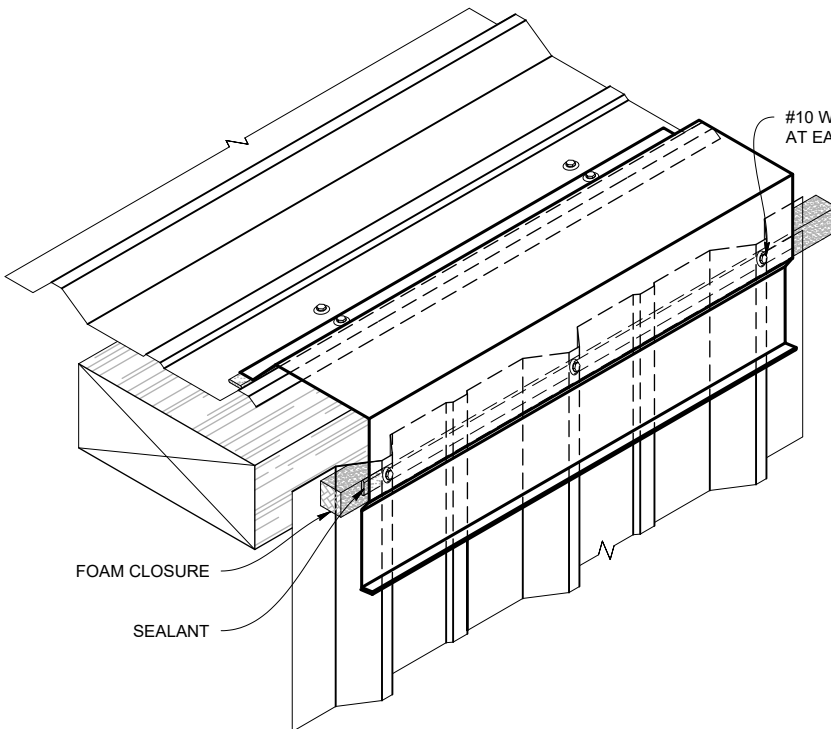
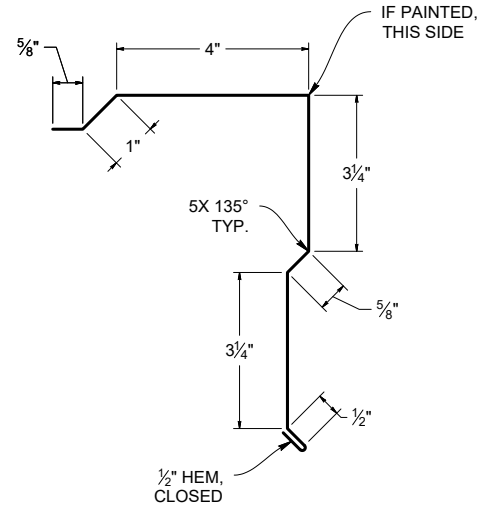

## PART SHOWN: (T3SG8) 2 x 8 STEP GABLE

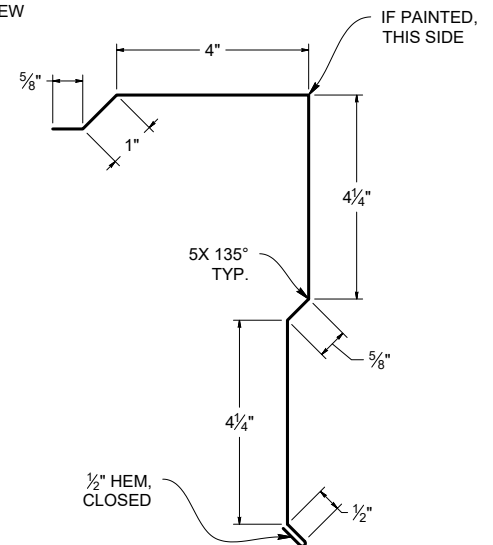

# Peak Flashing

(Ridge End Cap)

## PEAK FLASHING DETAIL

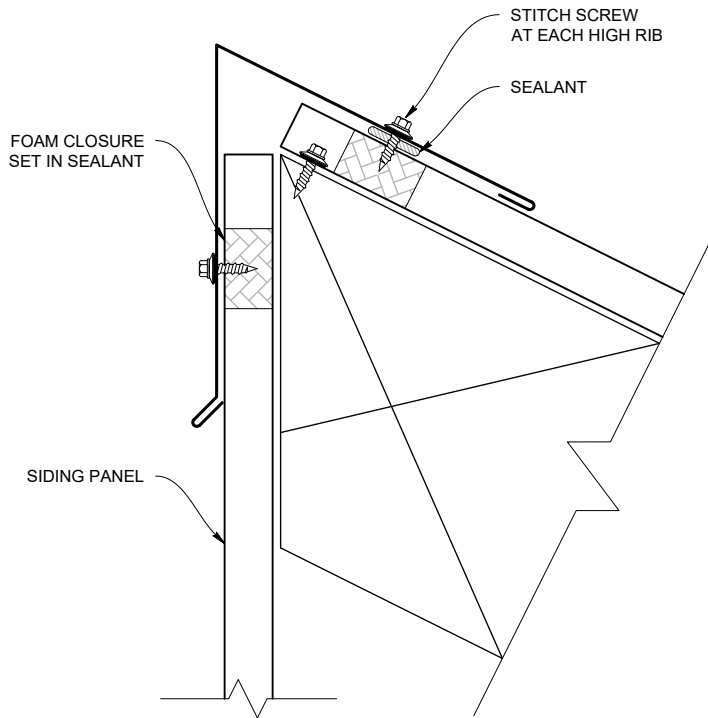

## PART SHOWN: (T3RP4) PEAK FLASHING

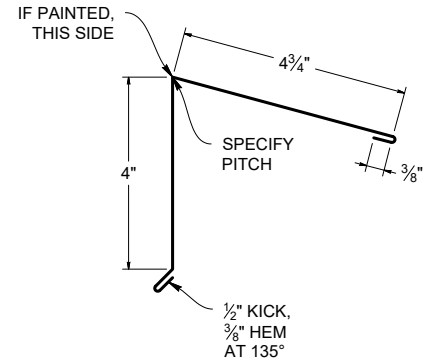

## PART SHOWN: (T3RP) PEAK FLASHING

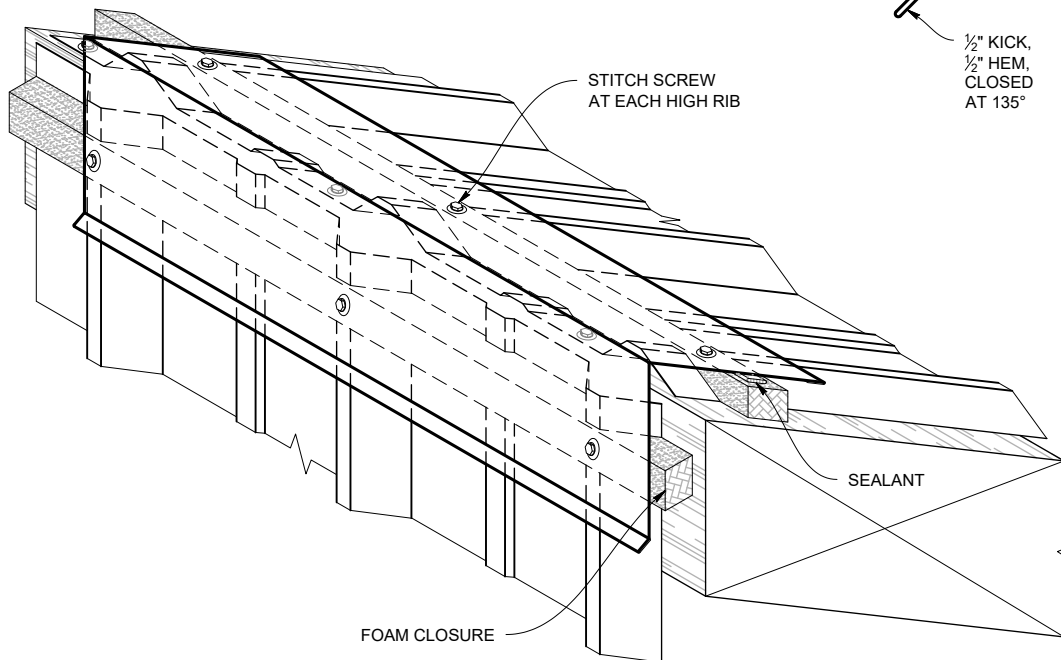
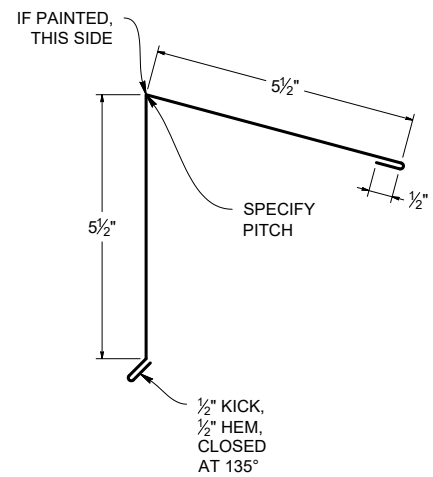

## SIDEWALL DETAIL

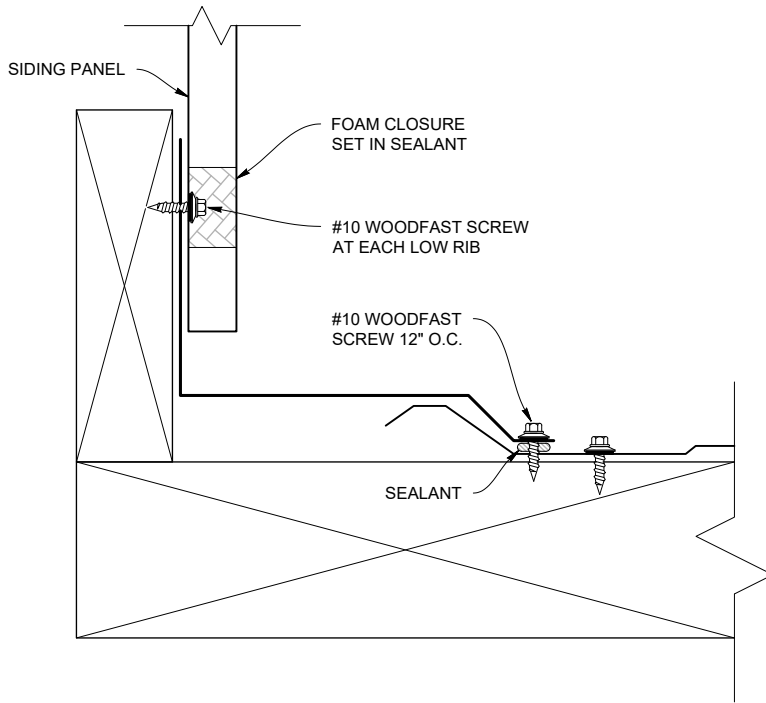

**PART SHOWN: (T3SW)  
.75" SIDEWALL**

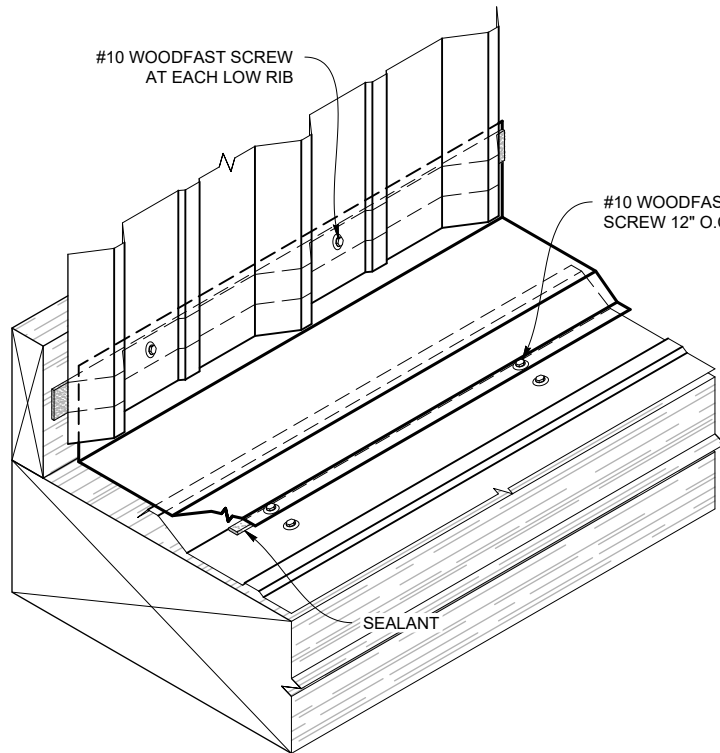
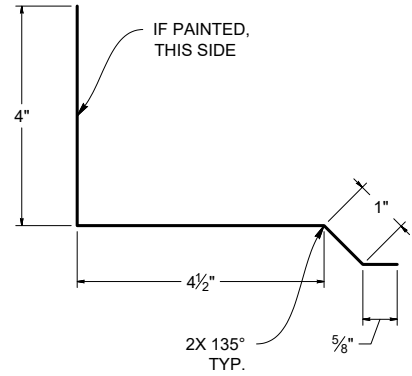

## ENDWALL DETAIL

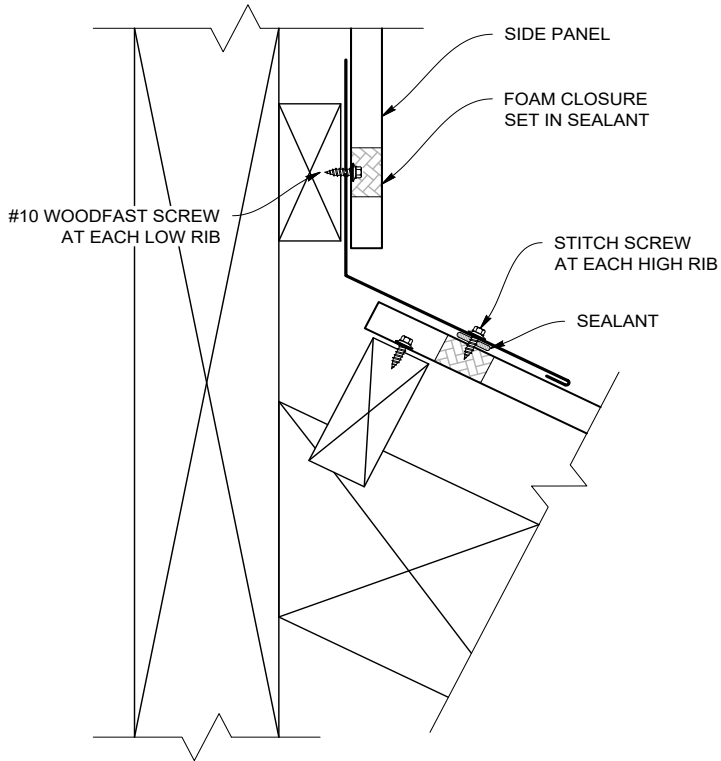

## PART SHOWN: (T3EW) ENDWALL

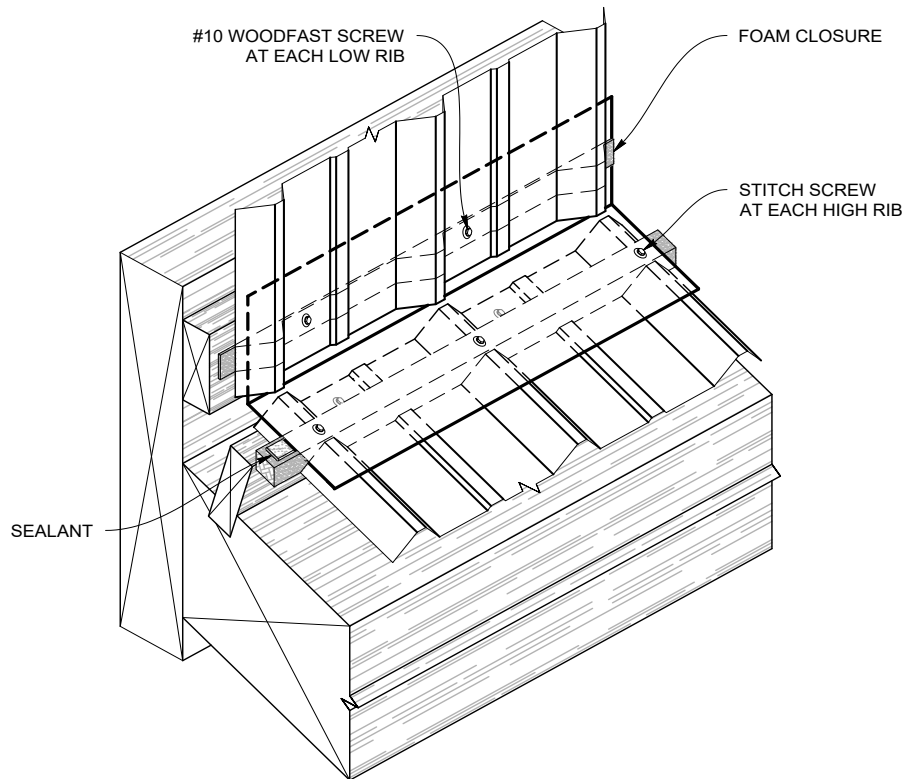
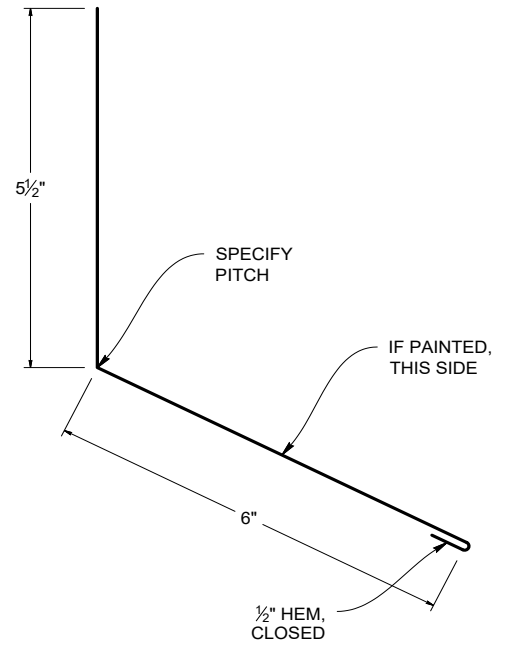

## ENDWALL DETAIL

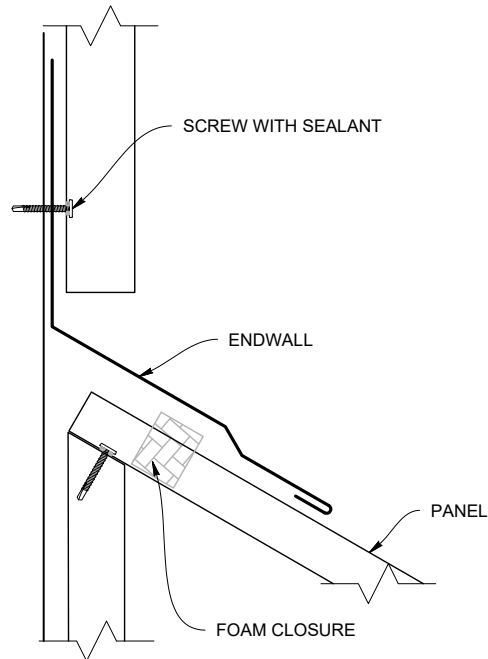

## PART SHOWN: (T3AEW) ALTERNATE ENDWALL

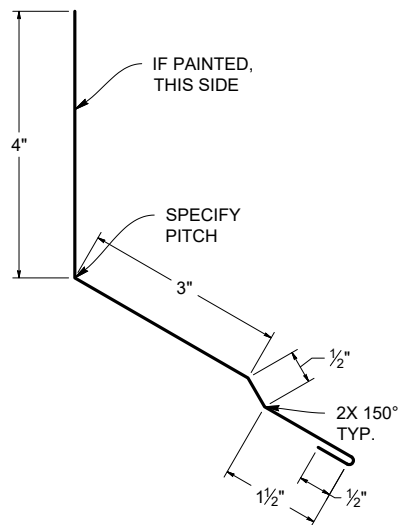

# Lapping Application

**PART SHOWN: (T3GS)  
STANDARD GABLE**

## LAPPING APPLICATION

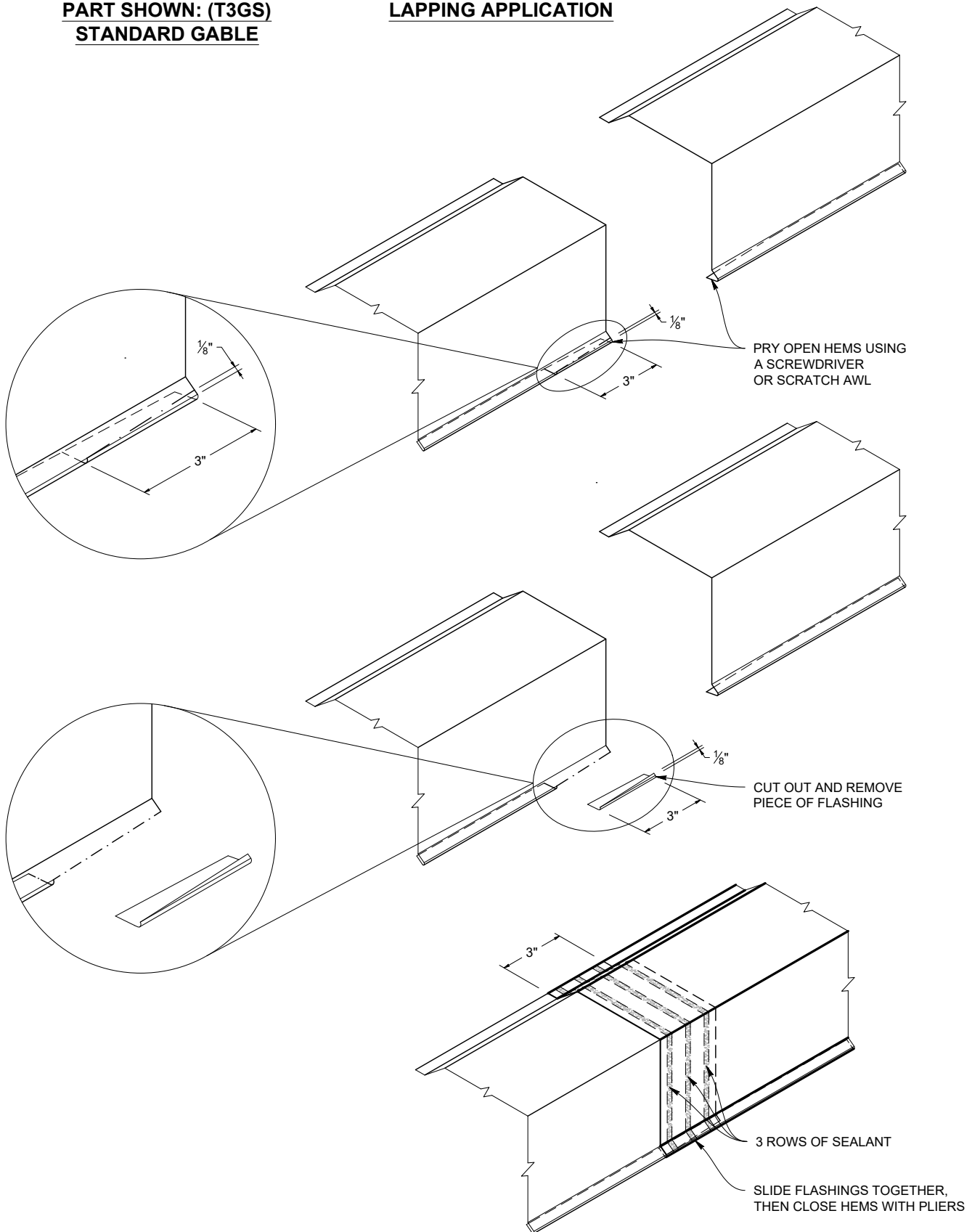

## SHORT PANEL END LAP DETAIL (PANEL: T-3)

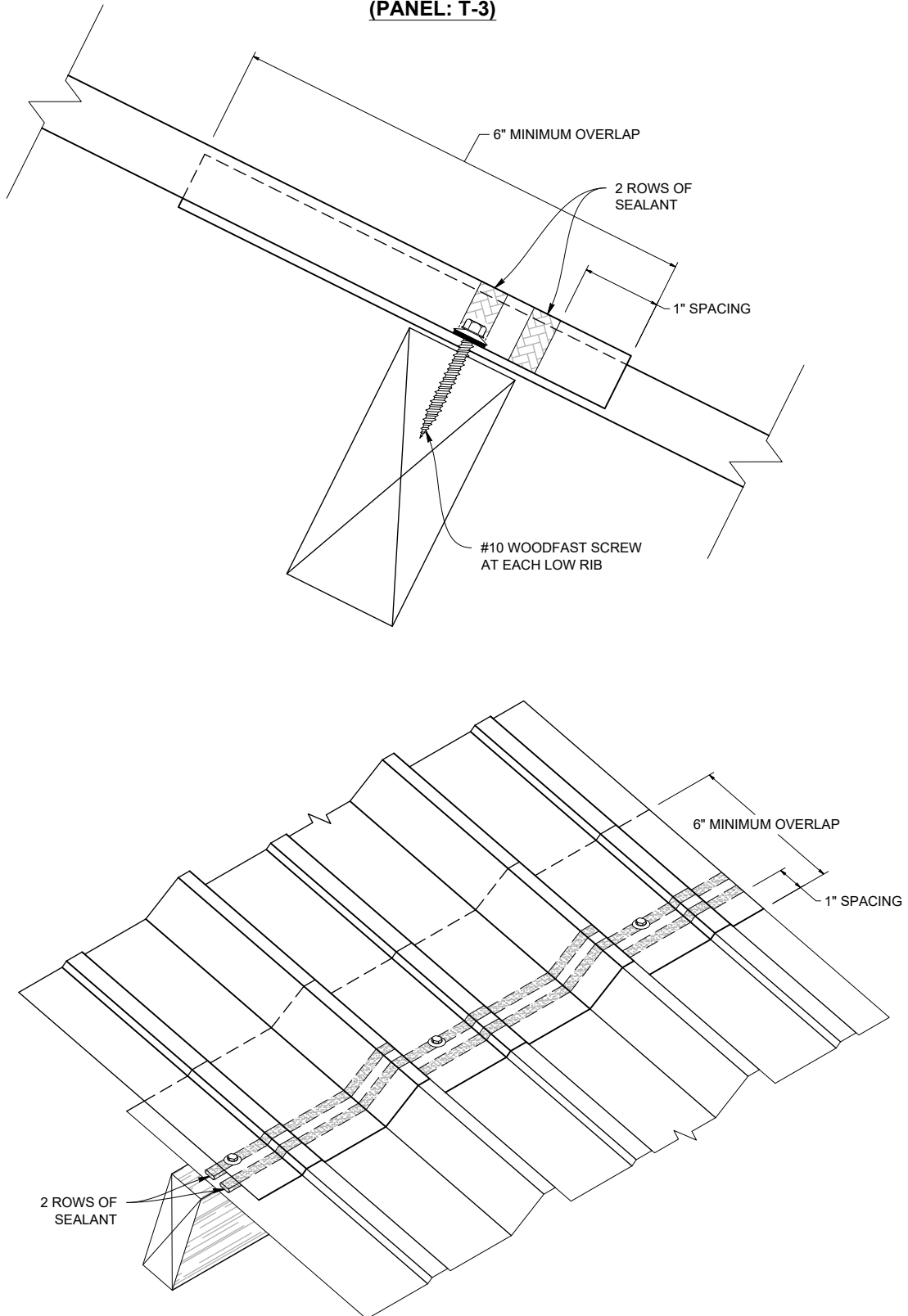

## LONG PANEL END LAP DETAIL (PANEL: T-3)

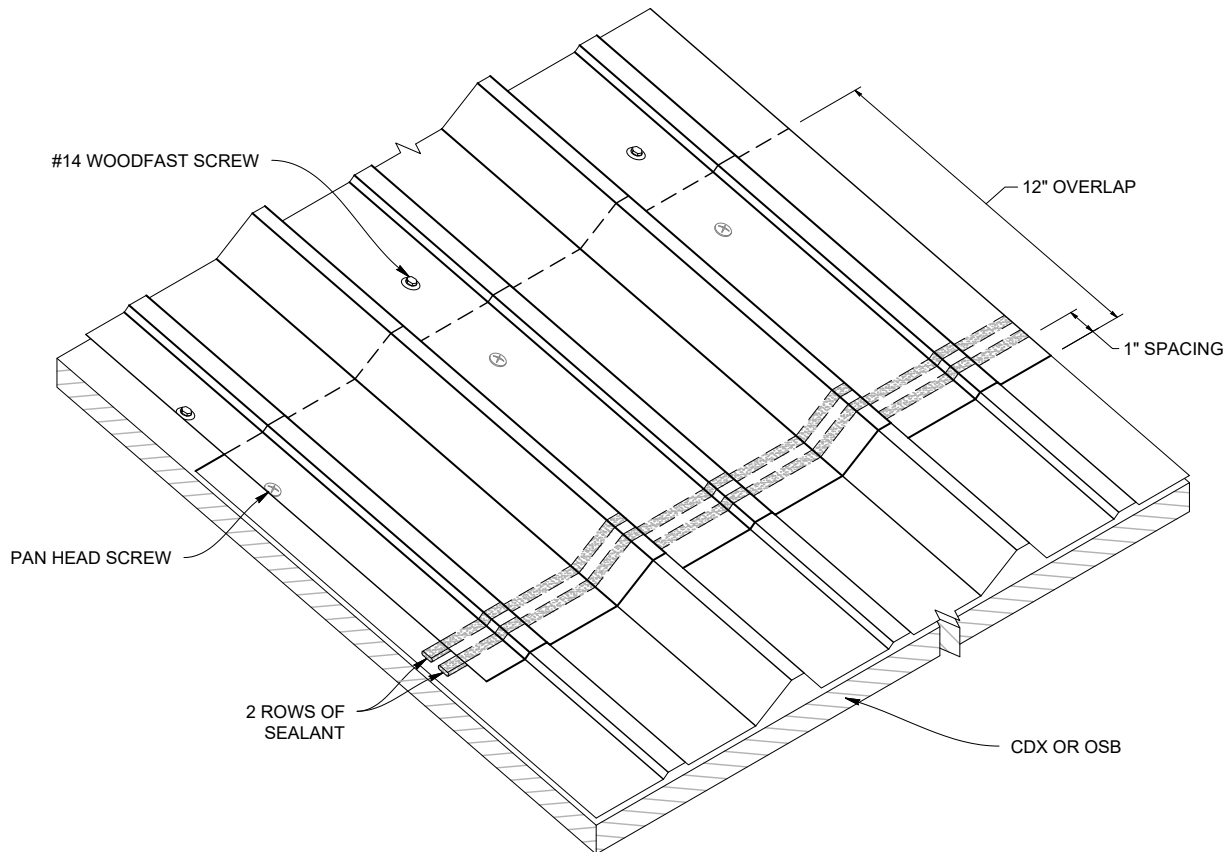
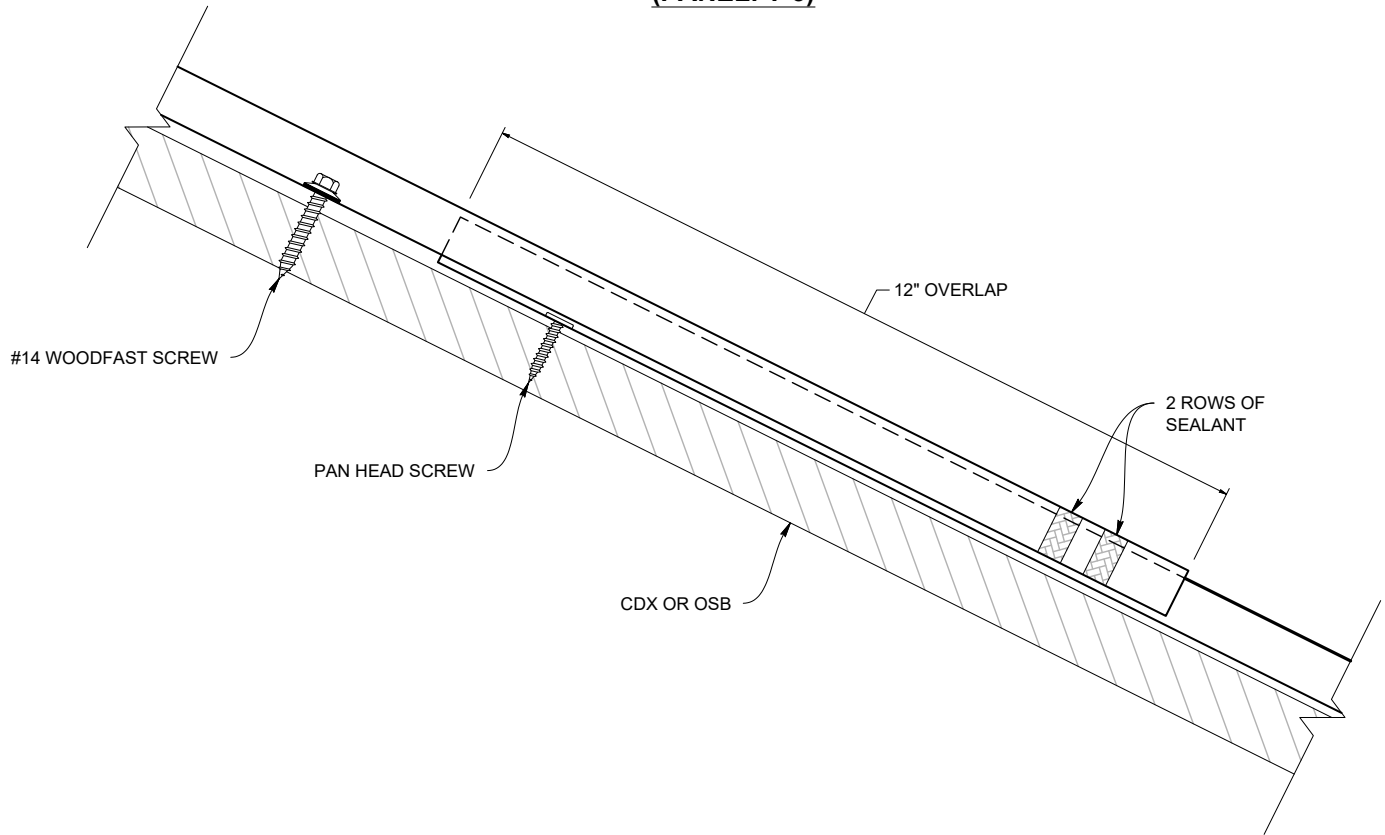

## BASE FLASHING DETAIL

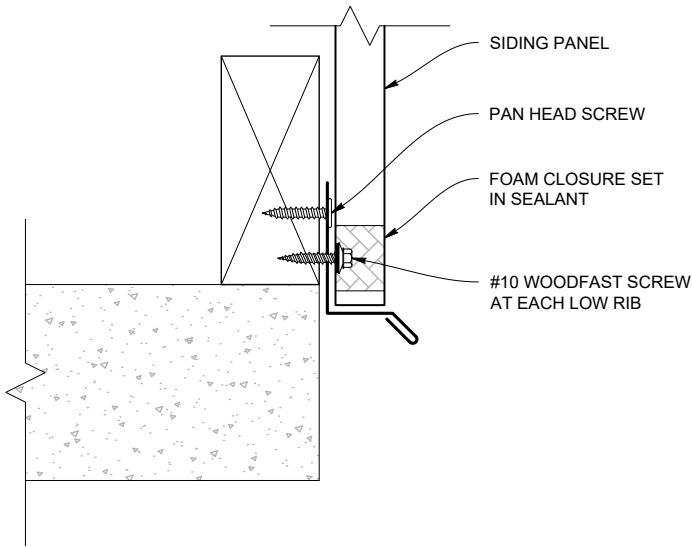

## PART SHOWN: (T3BF) .75" BASE FLASHING

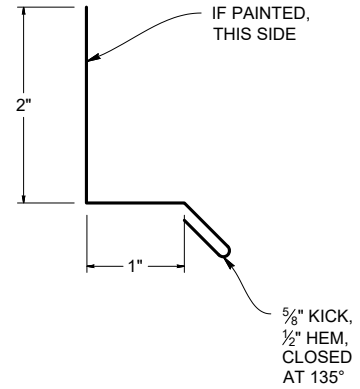

## C-FLASHING DETAIL (TOP VIEW)

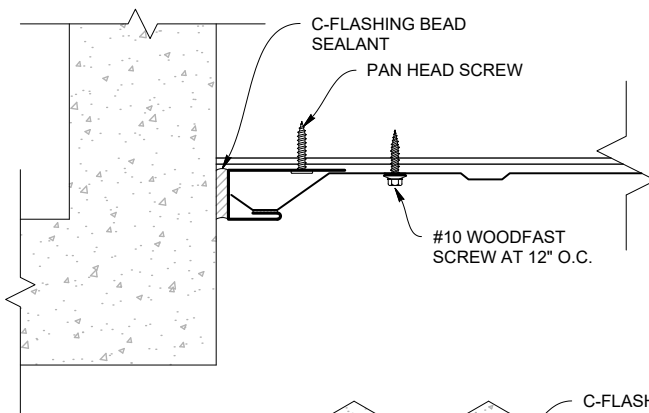

## PART SHOWN: (T3CF) .75" C-FLASHING

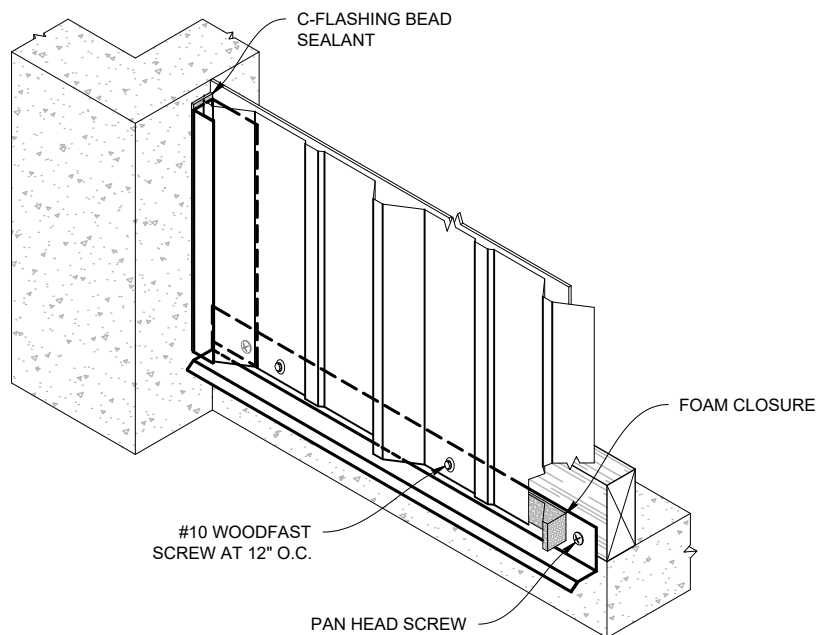
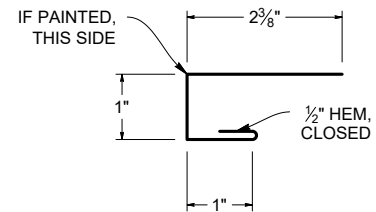

## INSIDE CORNER DETAIL

**PART SHOWN: (T3CI)**  
**.75" INSIDE CORNER**

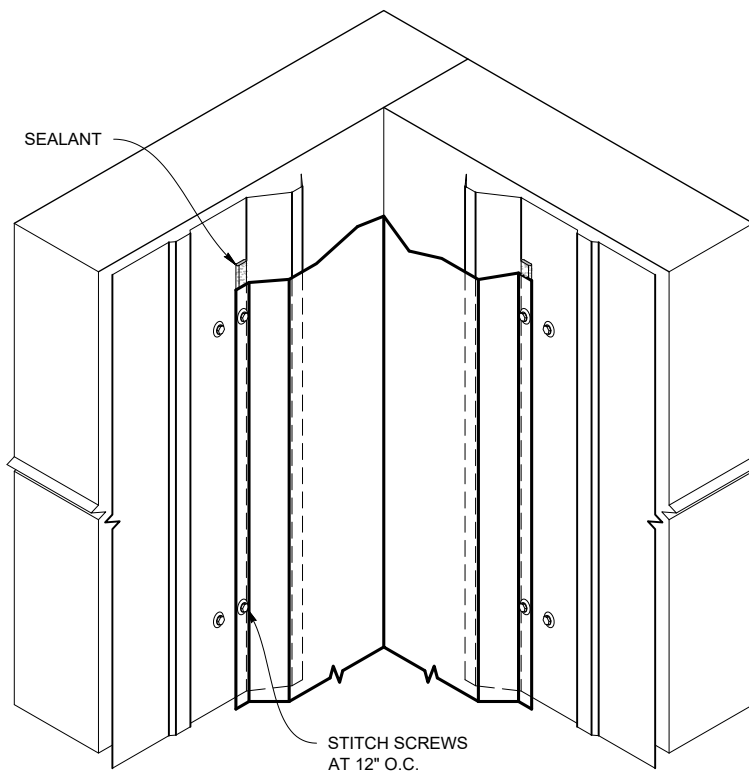
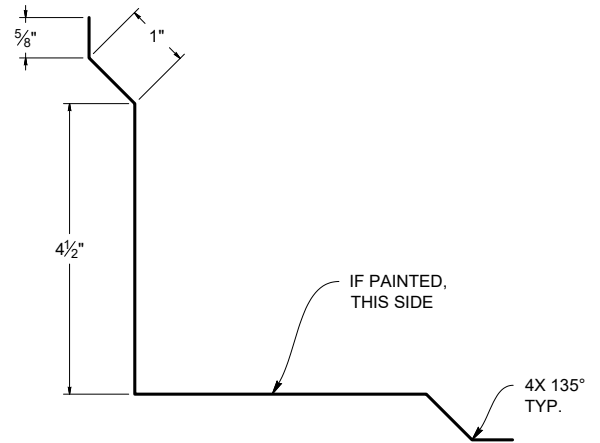
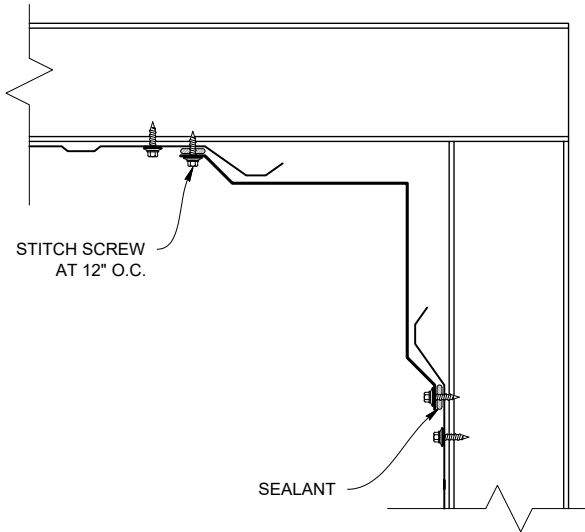

## INSIDE CORNER DETAILS

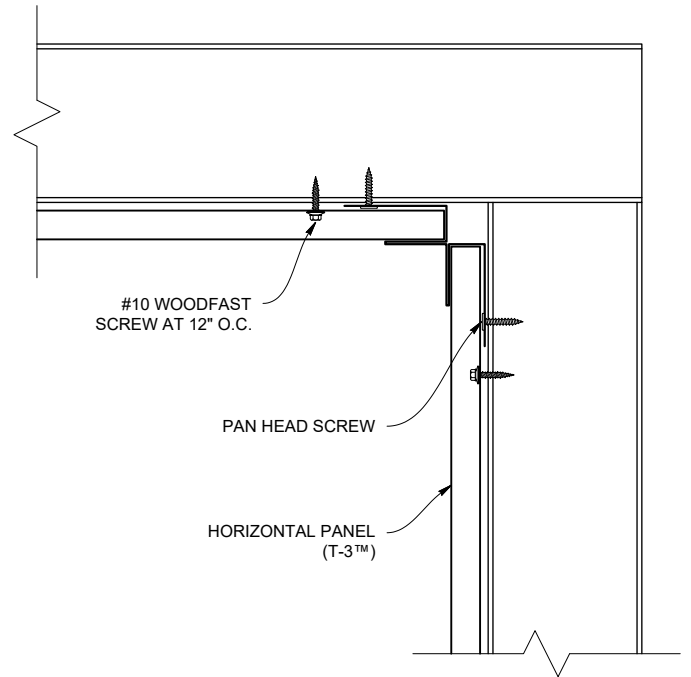
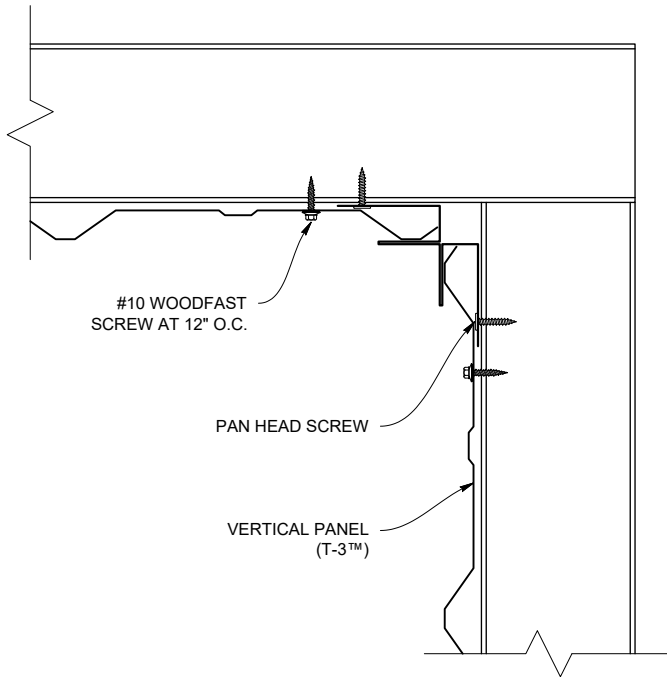

**PART SHOWN: (T3CPI)  
.75" INSIDE CORNER POST**

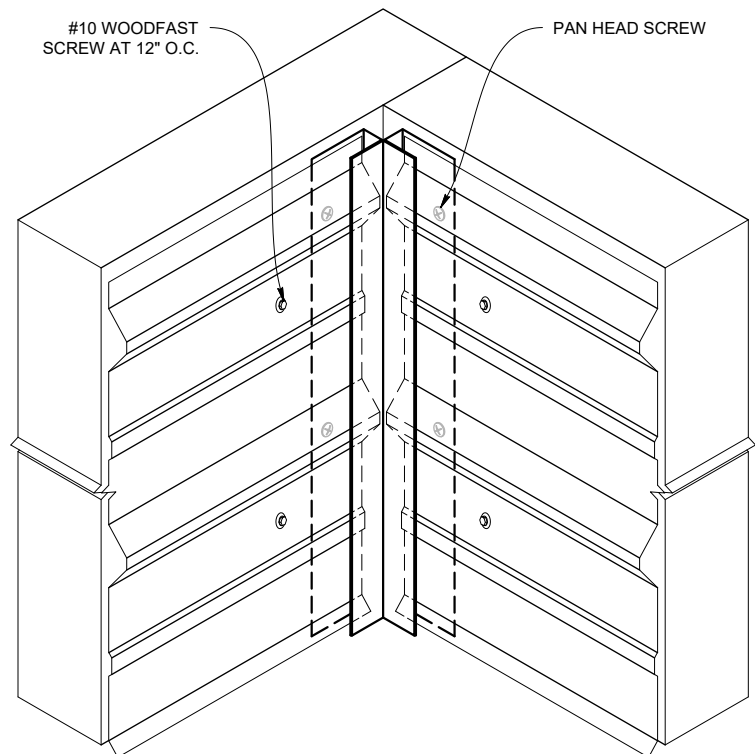
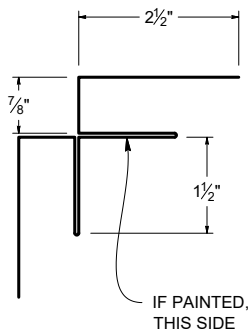

## OUTSIDE CORNER DETAIL

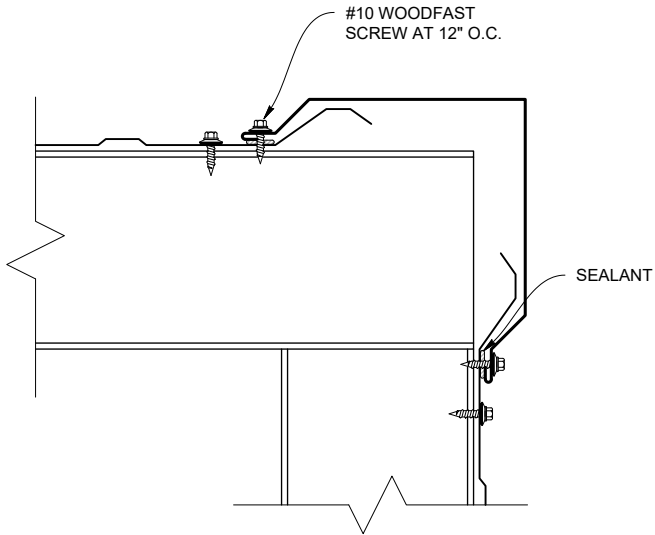

## PART SHOWN: (T3CO) .75" OUTSIDE CORNER

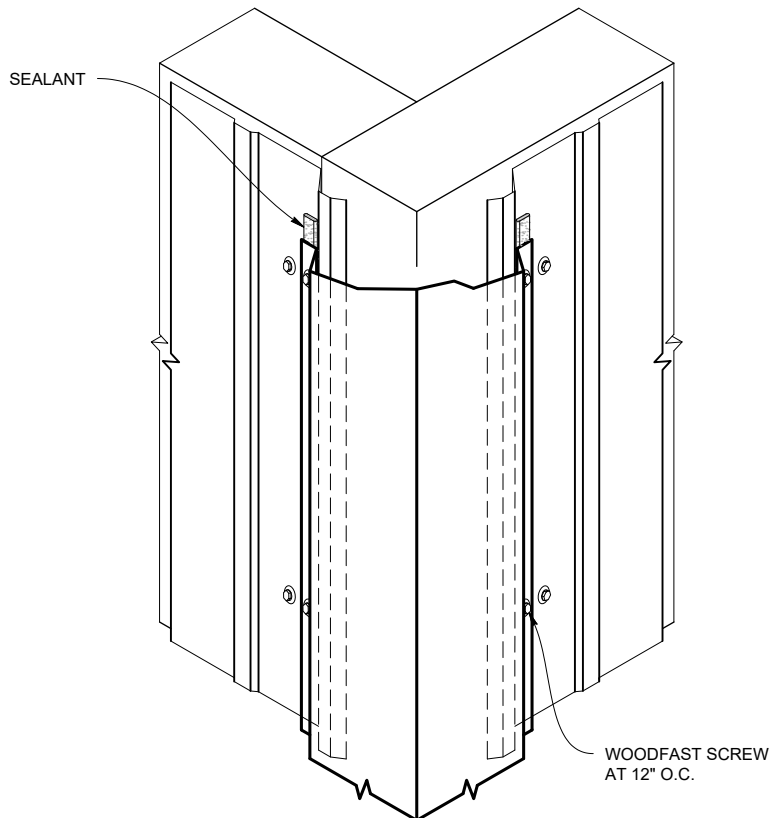
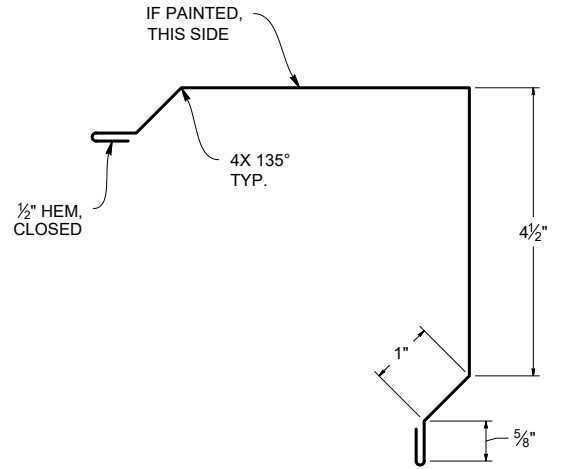

## OUTSIDE CORNER DETAILS

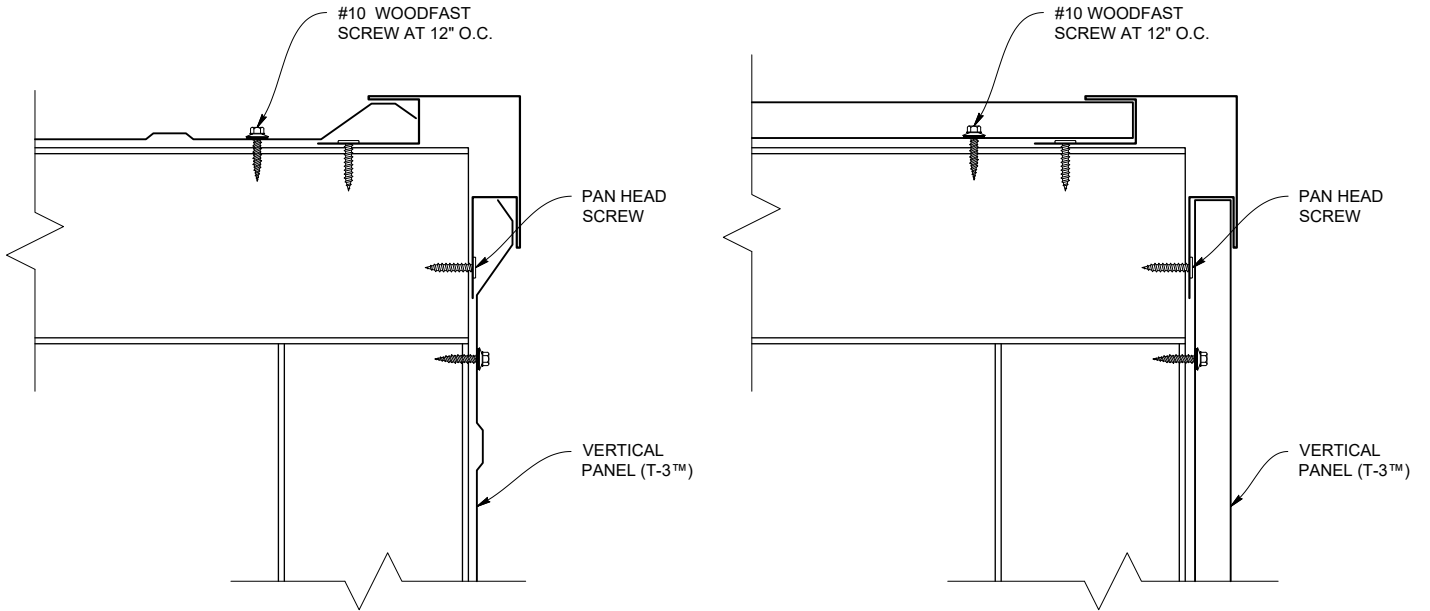

**PART SHOWN: (T3CPO)  
.75" OUTSIDE CORNER POST**

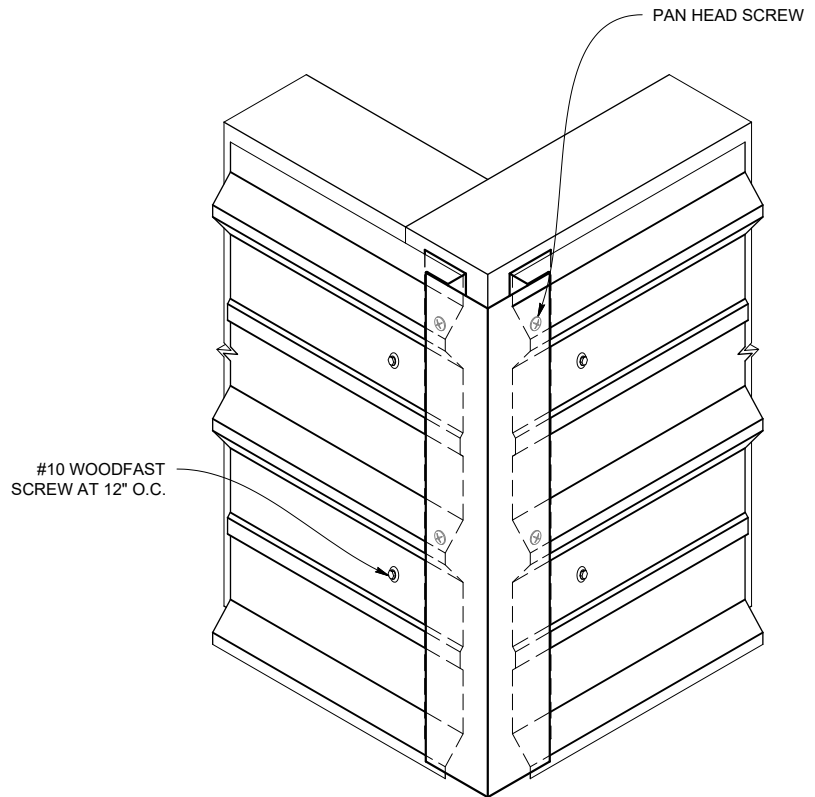
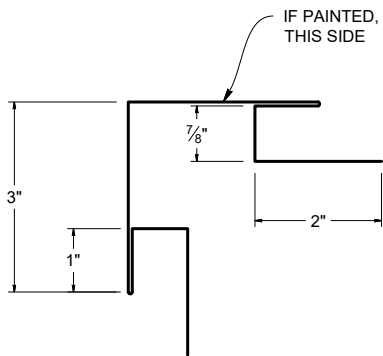

## MINI CORNER DETAIL

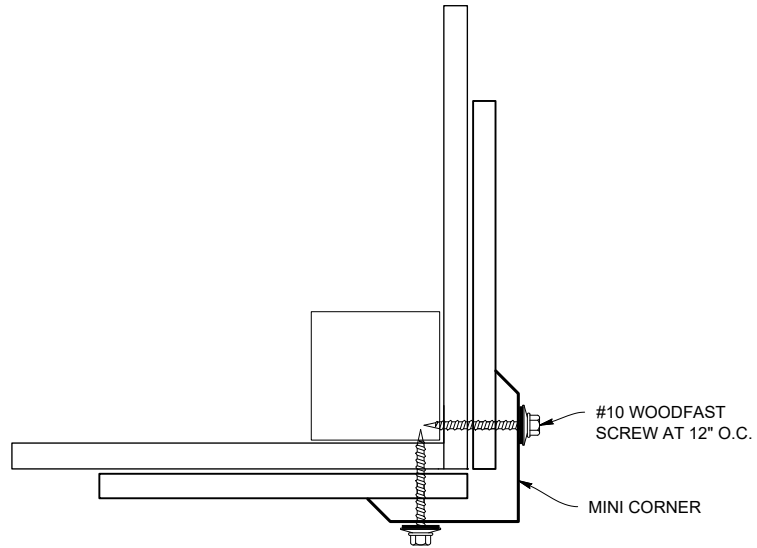

## PART SHOWN: (T3MC) .75" OUTSIDE MINI CORNER

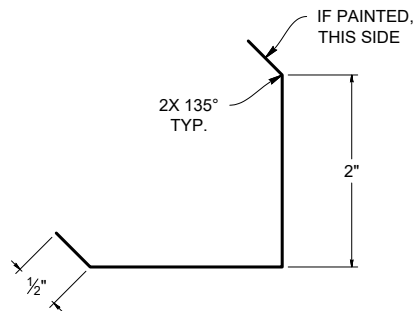

## INSIDE PITCH CHANGE DETAIL

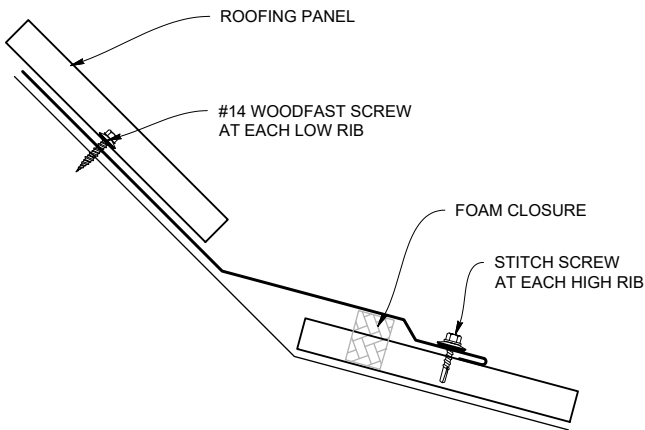

**PART SHOWN: (T3APCI)**  
**.75" ALTERNATE INSIDE PITCH CHANGE**

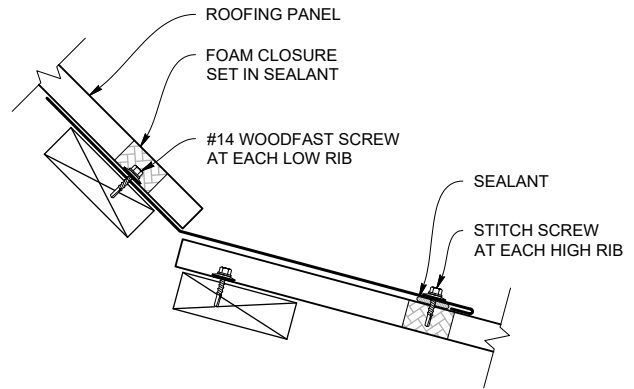

**PART SHOWN: (T3PCI)**  
**.75" INSIDE PITCH CHANGE**

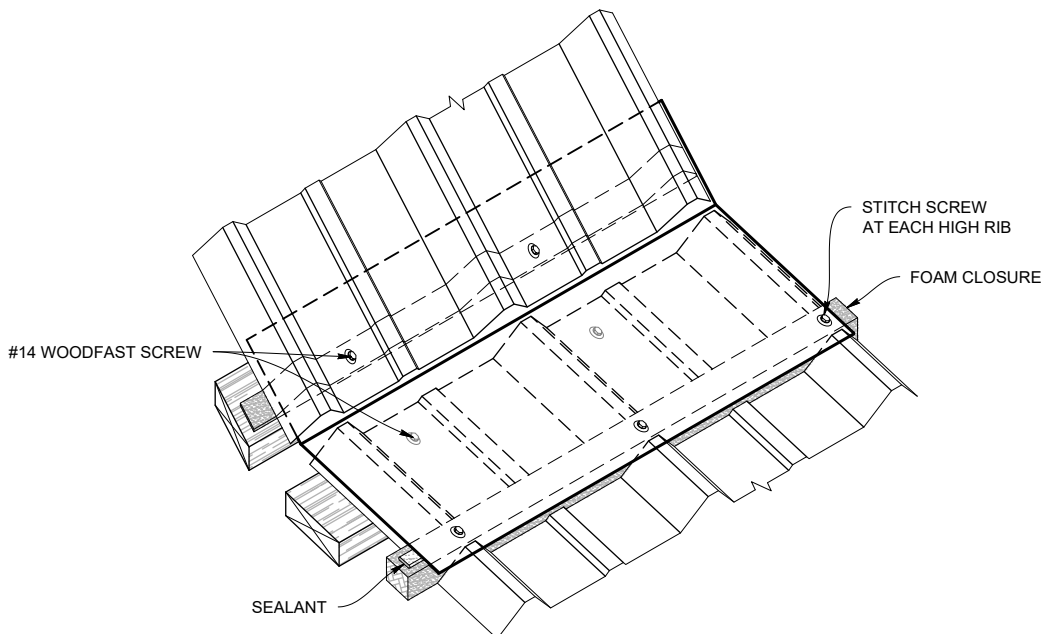
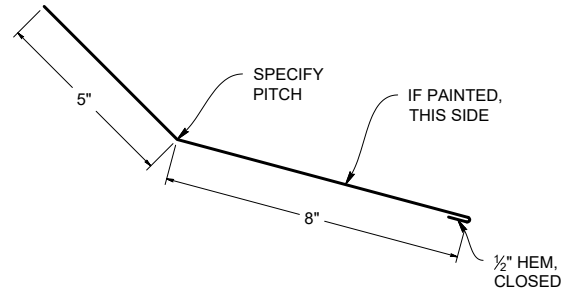
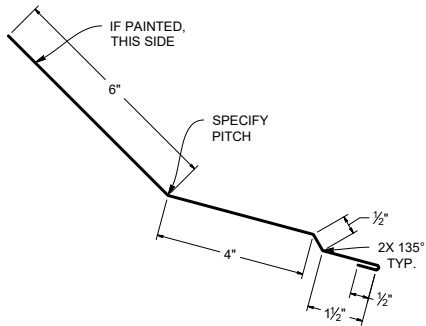

## OUTSIDE PITCH CHANGE DETAIL

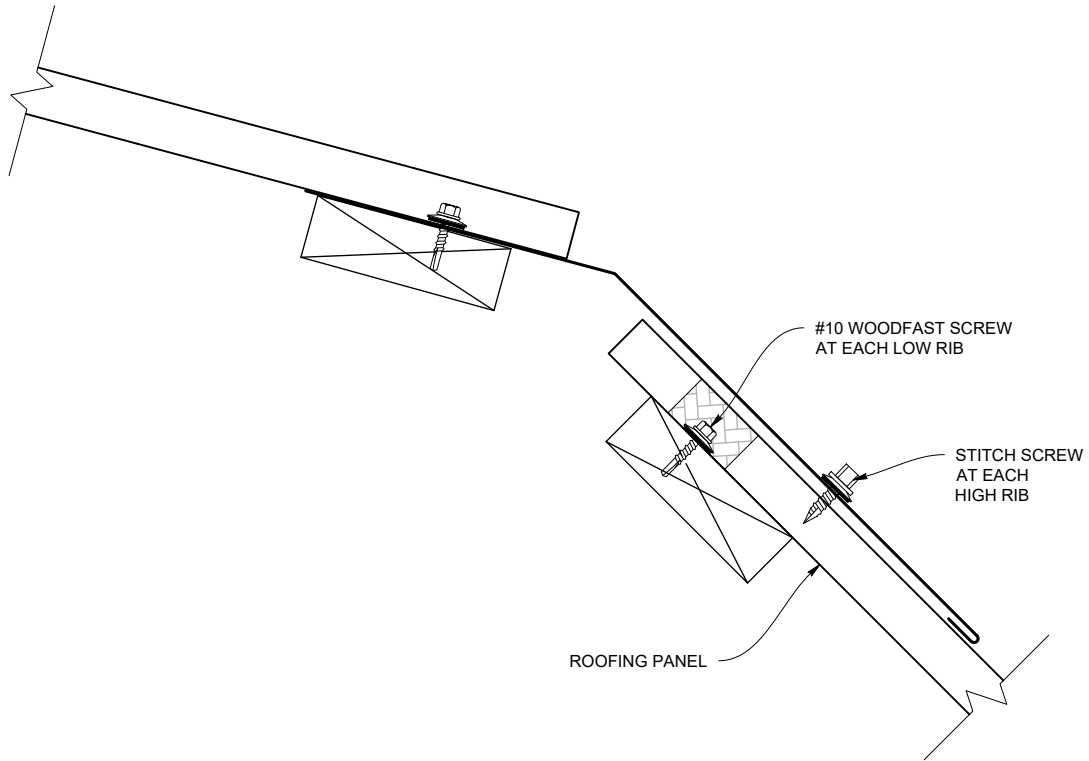

## PART SHOWN: (T3PCO) .75" OUTSIDE PITCH CHANGE

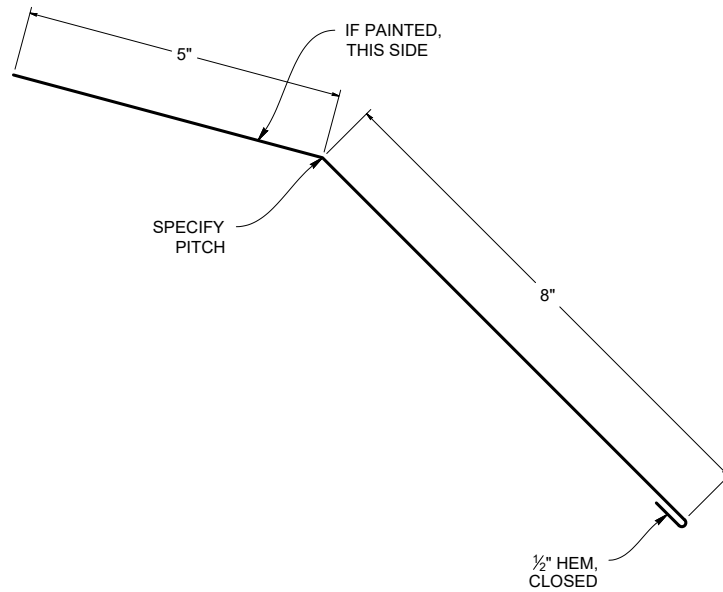

## SOFFIT RIDGE DETAIL

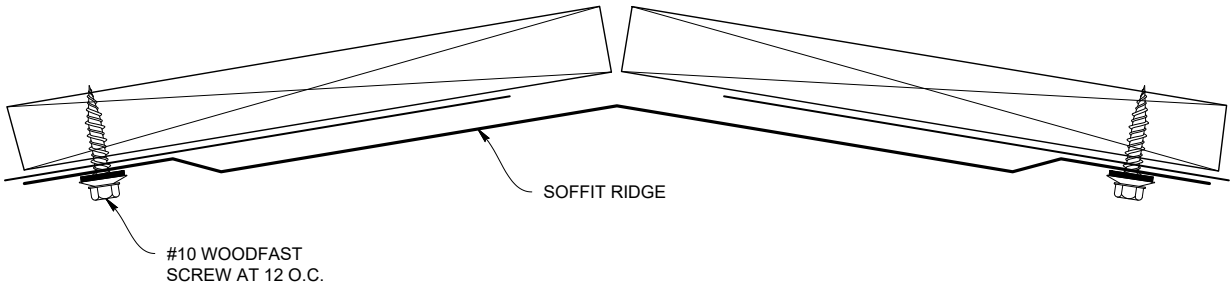

## PART SHOWN: (T3SR) SOFFIT RIDGE

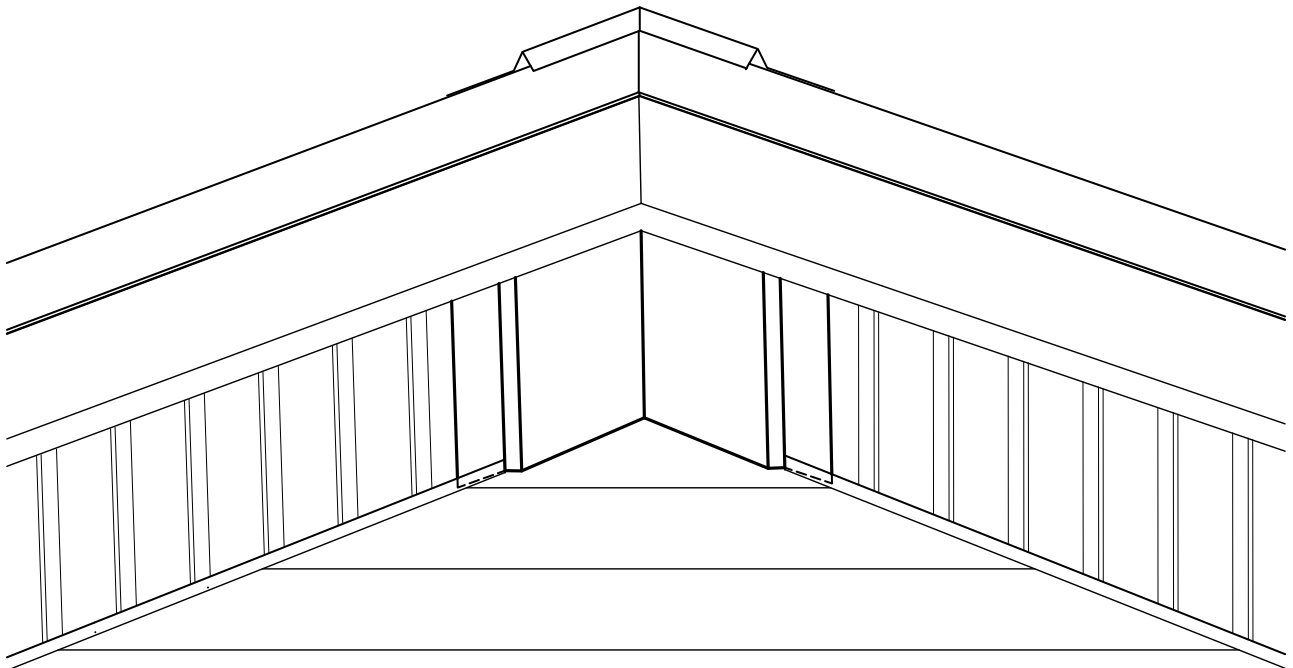
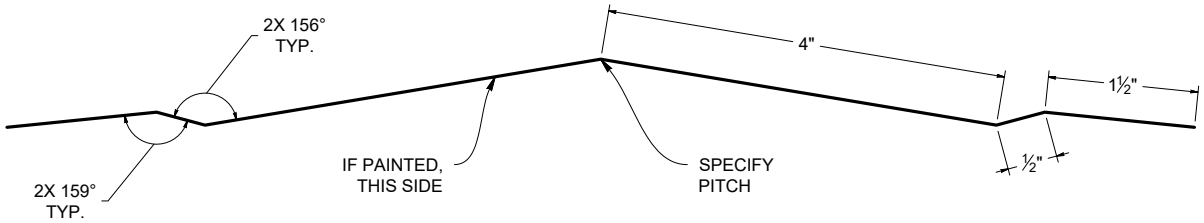

**PART SHOWN: (T3ATCS)  
SINGLE TRACK COVER**

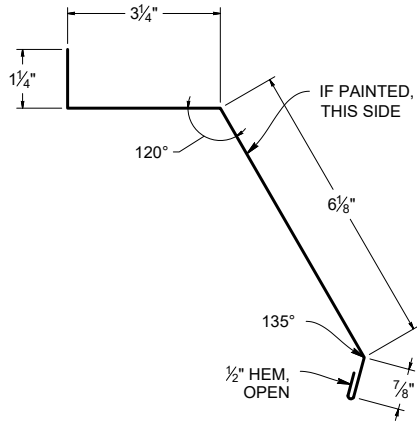

**SINGLE TRACK COVER DETAIL**

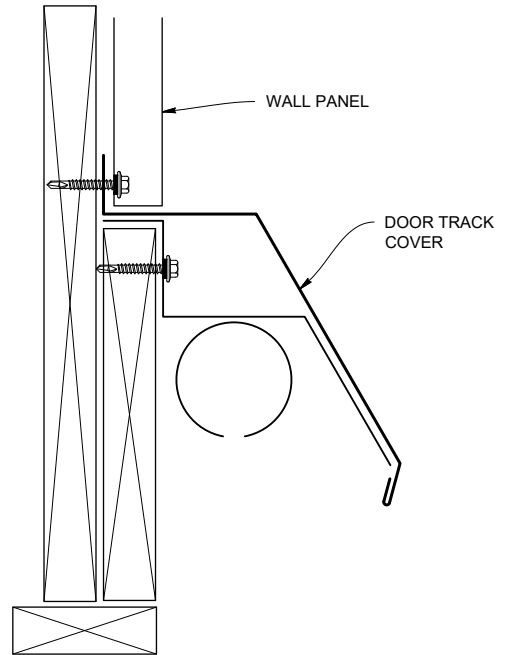

**PART SHOWN: (T3ATCD)  
DOUBLE TRACK COVER**

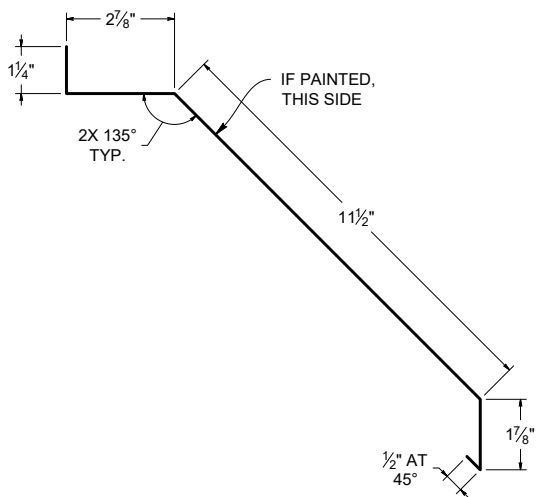

**DOUBLE TRACK COVER DETAIL**

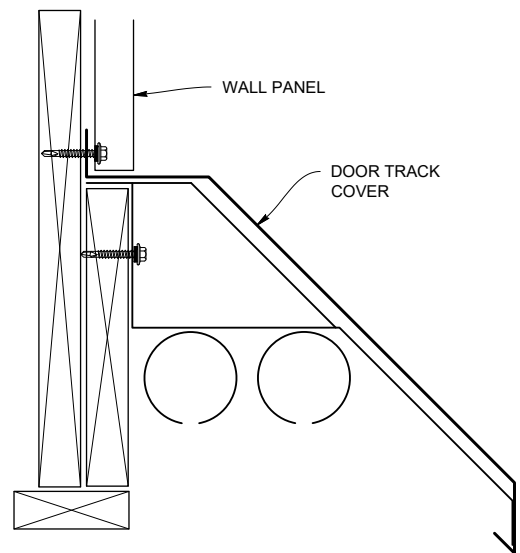

## PAN FLASHING DETAIL

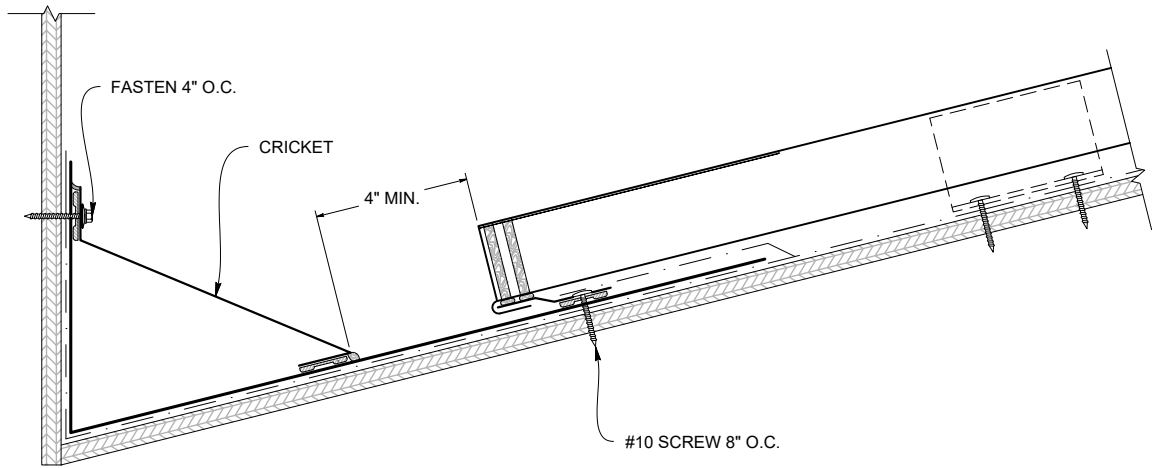

## PART SHOWN: (T3PAN) .75" PAN FLASHING

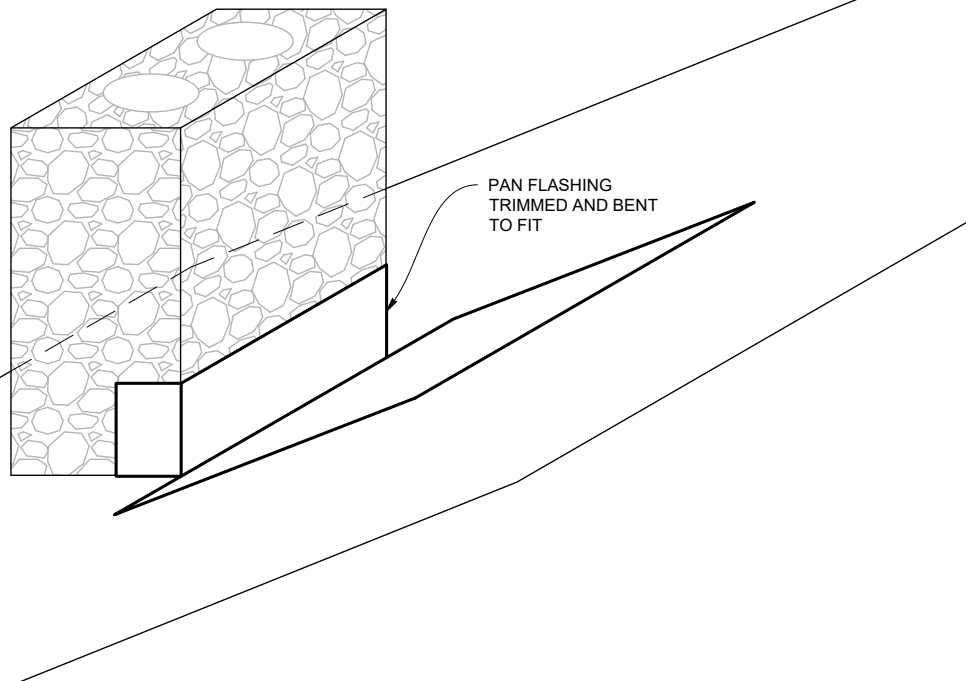
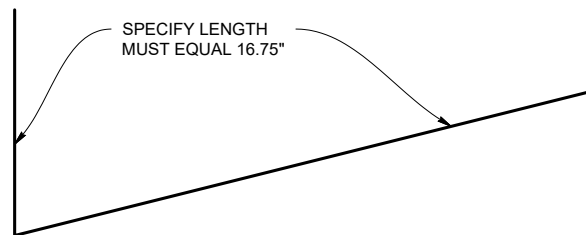

## PROW FLASHING DETAIL

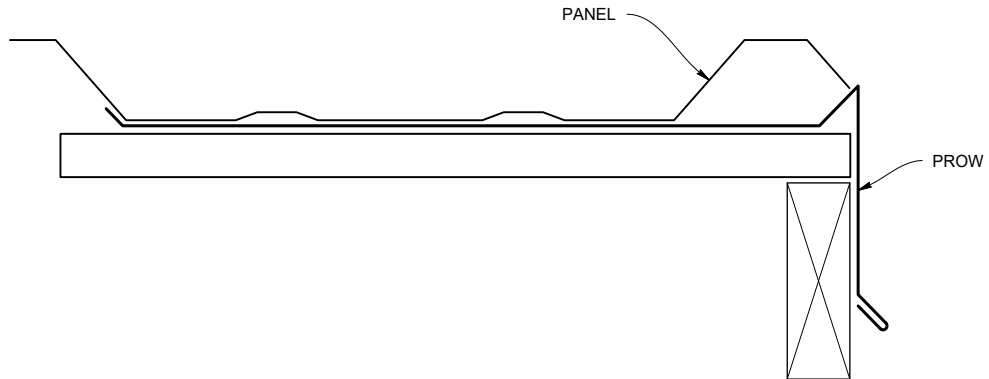

## PART SHOWN: (T3PF) .75" PROW FLASHING

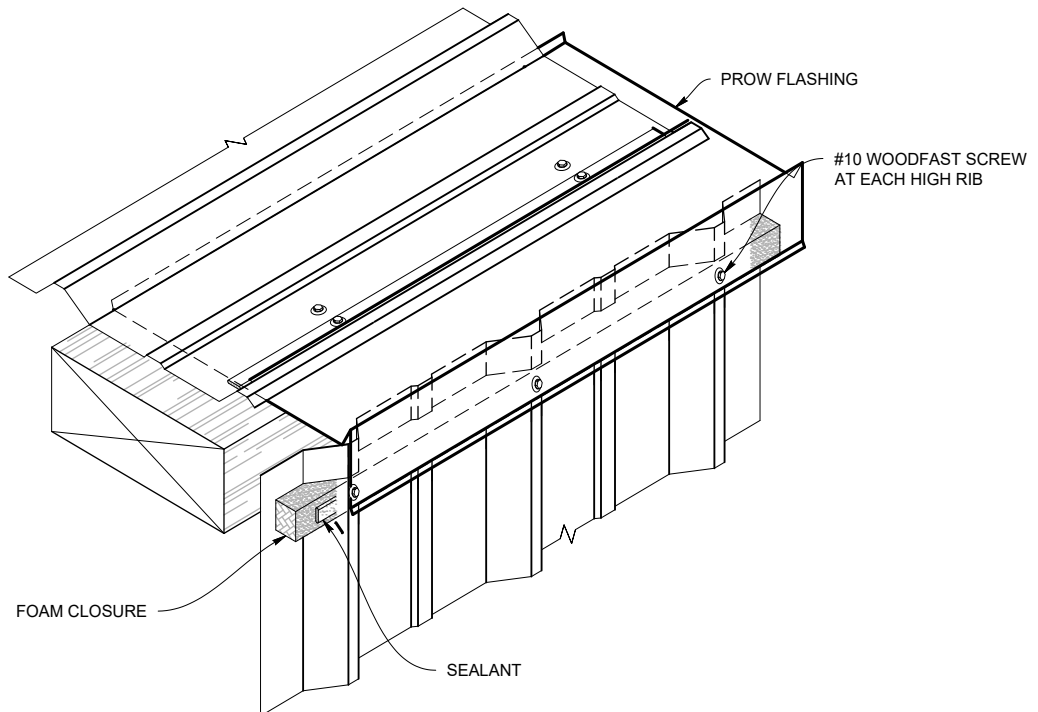
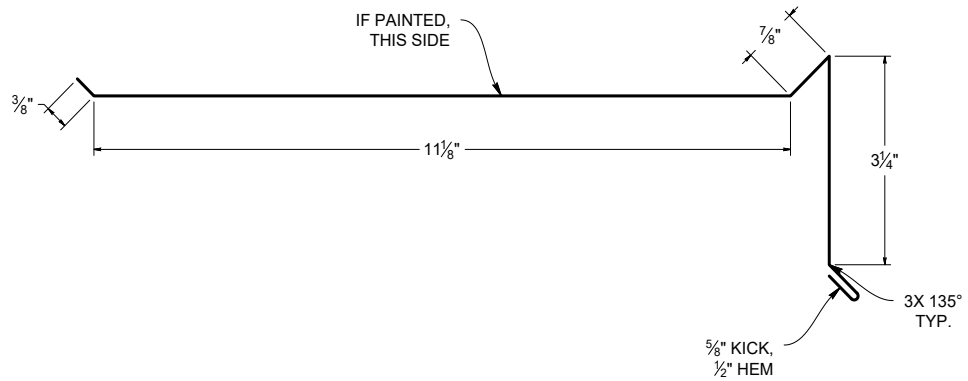

**DOOR JAMB DETAIL**

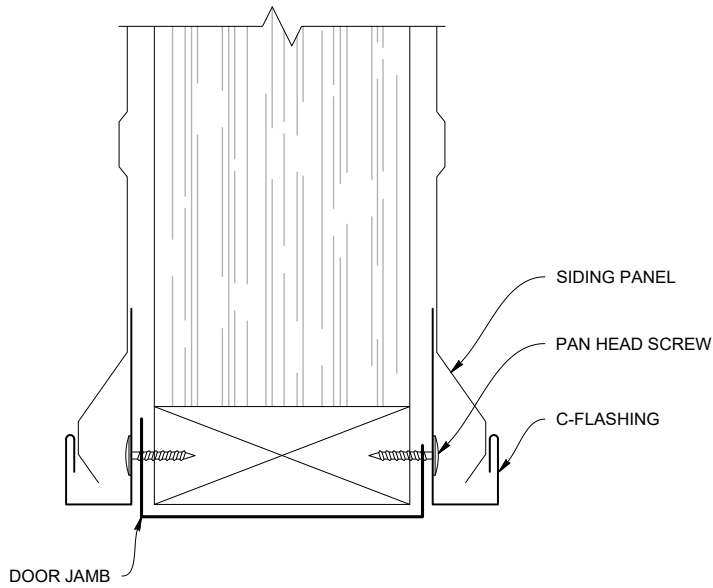

**PART SHOWN: (DJ5)  
DOOR JAMB 4-5/8" TO 7-1/2"**

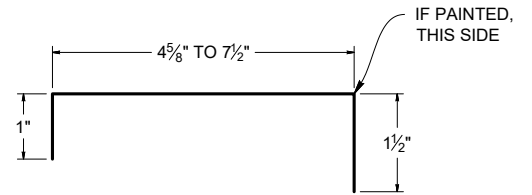

**PART SHOWN: (T3CF)  
.75" C-FLASHING**

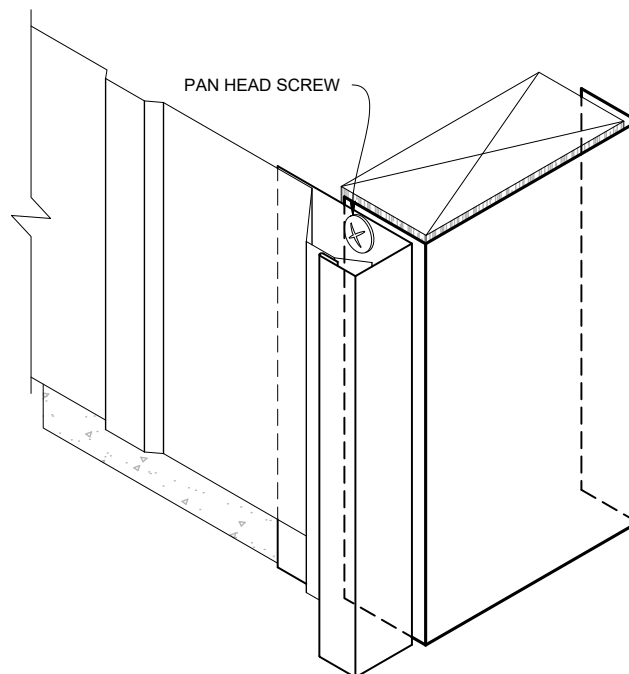
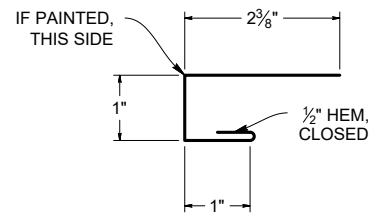

# Through Fastener Flashing Selections

Tuff Rib, T3, GR-7, GR-5

Standard: 29/26GA: 12'6, 24GA:10'



<p><b>.75" EAVE TRIM ( T3CET )</b></p> <p>SCALE 1:6                      S.O. 12"                      WEIGHT: 9 LBS.</p>	<p><b>.75" GUTTER EAVE TRIM ( T3CETG )</b></p> <p>SCALE 1:4                      S.O. 5.5"                      WEIGHT: 4.2 LBS.</p>
<p><b>STANDARD EAVE ( T3ES )</b></p> <p>SCALE 1:5                      S.O. 6"                      WEIGHT: 4.6 LBS.</p>	<p><b>4" EAVE ( T3E4 )</b></p> <p>SCALE 1:5                      S.O. 8.25"                      WEIGHT: 6.3 LBS.</p>
<p><b>.75" 2X6 STEP EAVE ( T3SE6 )</b></p> <p>SCALE 1:5                      S.O. 11.375"                      WEIGHT: 8.5 LBS.</p>	<p><b>.75" STANDARD GABLE ( T3GS )</b></p> <p>SCALE 1:5                      S.O. 12.25"                      WEIGHT: 9 LBS.</p>

**.75" STYLE G  
( T3STG )**

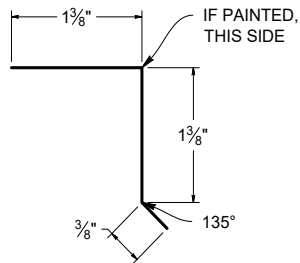

SCALE 1:2

S.O. 3.125"

WEIGHT: 10.5 LBS.

**.75" SPECIAL STYLE G  
( T3SSTG )**

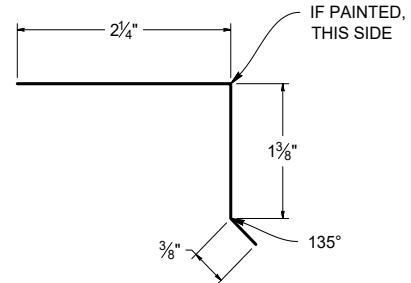

SCALE 1:2

S.O. 4"

WEIGHT: 5.3 LBS.

**.75" 3X3 DRIP  
( T3E33 )**

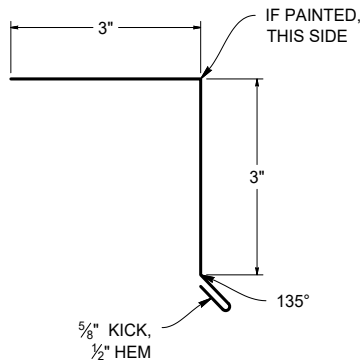

SCALE 1:3

S.O. 7.125"

WEIGHT: 10.5 LBS.

**.75" GABLE TRIM - LARGE  
( T3CGL )**

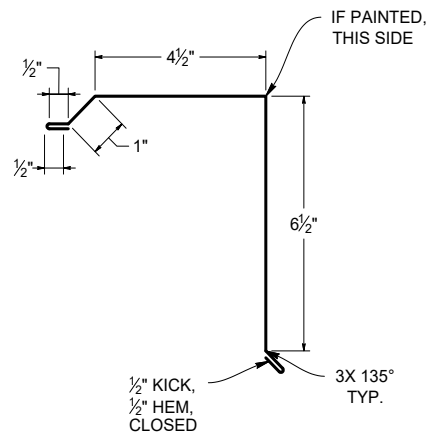

SCALE 1:5

S.O. 14"

WEIGHT: 10.5 LBS.

**.75" GABLE TRIM - MINI  
( T3CMG )**

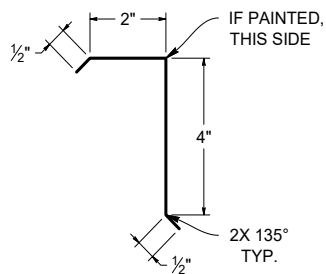

SCALE 1:5

S.O. 7"

WEIGHT: 5.3 LBS.

**.75" 2X6 STEP GABLE  
( T3SG6 )**

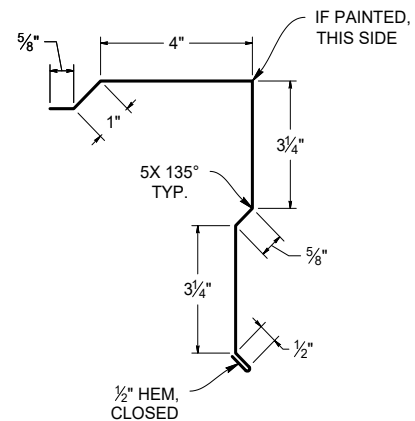

SCALE 1:5

S.O. 13.75"

WEIGHT: 10.5 LBS.

# Through Fastener Flashing Selections

Tuff Rib, T3, GR-7, GR-5

Standard: 29/26GA: 12'6, 24GA:10'



## .75" 2X8 STEP GABLE ( T3SG8 )

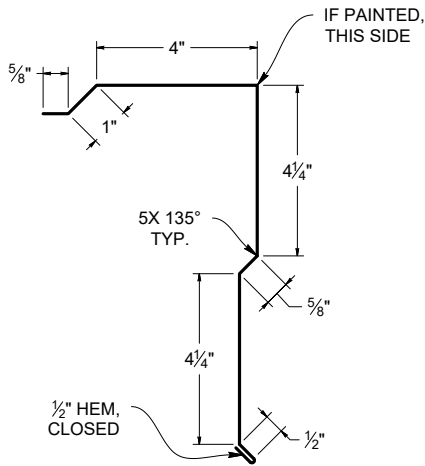

SCALE 1:5 S.O. 15.75" WEIGHT: 12 LBS.

## MODIFIED MINI GABLE ( T3MMG )

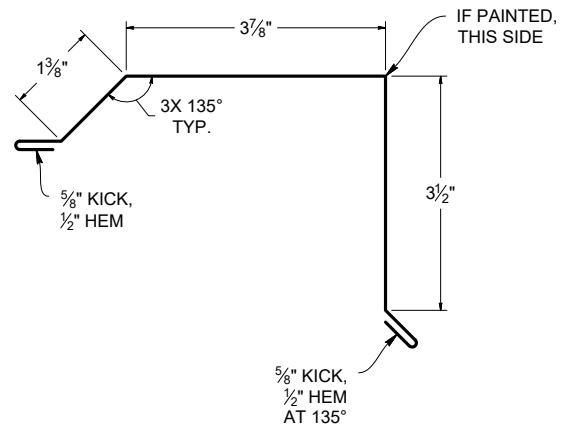

SCALE 1:3 S.O. 11" WEIGHT: 9.6 LBS.

## .75" PROW ( T3PF )

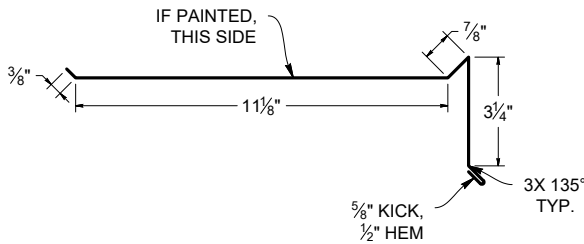

SCALE 1:6 S.O. 16.75" WEIGHT: 5.6 LBS.

## PEAK CAP ( T3RP )

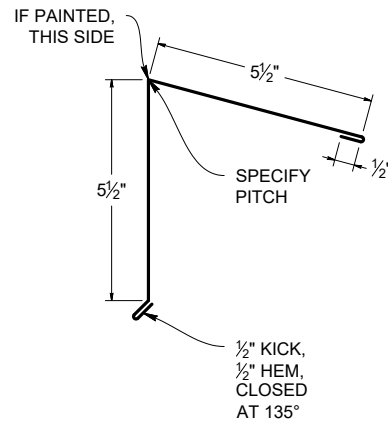

SCALE 1:5 S.O. 12.5" WEIGHT: 9.6 LBS.

## 4" PEAK CAP ( T3RP4 )

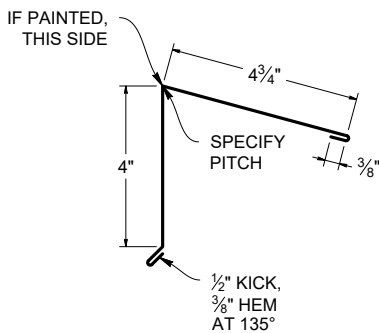

SCALE 1:5 S.O. 10" WEIGHT: 21 LBS.

## 28" W-VALLEY ( T3VF )

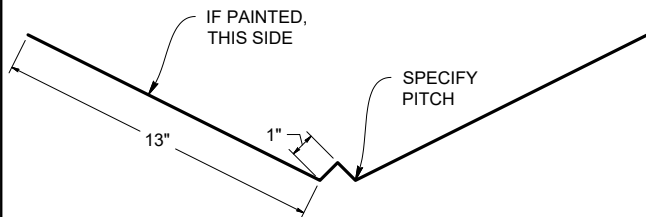

SCALE 1:8 S.O. 28" WEIGHT: 21 LBS.

**STANDARD RIDGE  
( T3RS )**

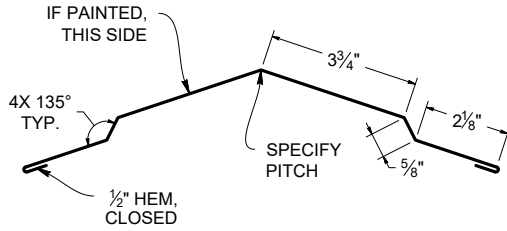

SCALE 1:5

S.O. 14"

WEIGHT: 10.5 LBS.

**VENTED/WIDE RIDGE  
( T3RVW )**

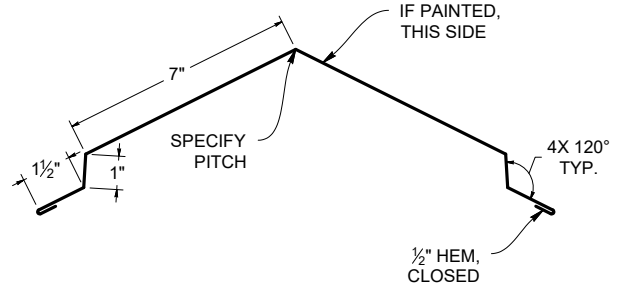

SCALE 1:6

S.O. 20"

WEIGHT: 15.2 LBS.

**CABIN RIDGE  
( T3CR )**

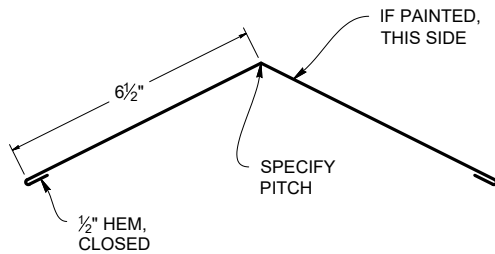

SCALE 1:5

S.O. 14"

WEIGHT: 10.5 LBS.

**UNIVERSAL RIDGE  
( T3UR )**

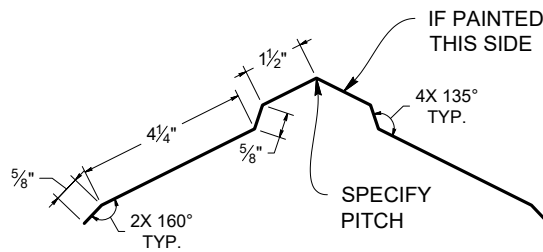

SCALE 1:5

S.O. 14"

WEIGHT: 10.5 LBS.

**LT RIDGE  
( T3RLT )**

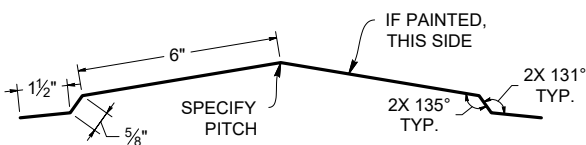

SCALE 1:6

S.O. 16.25"

WEIGHT: 21 LBS.

**HEMMED LT RIDGE  
( T3RLTH )**

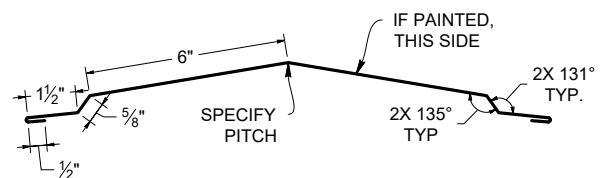

SCALE 1:6

S.O. 17.25"

WEIGHT: 21 LBS.

# Through Fastener Flashing Selections

Tuff Rib, T3, GR-7, GR-5

Standard: 29/26GA: 12'6, 24GA:10'



## SOFFIT RIDGE ( T3SR )

STANDARD LENGTH FOR THIS PART IS 3'

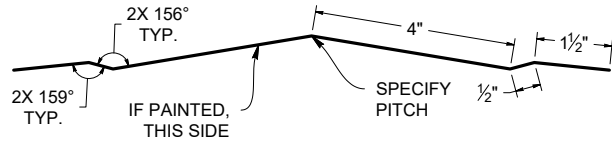

SCALE 1:4

S.O. 12"

WEIGHT: 21 LBS.

## INSIDE PITCH CHANGE ( T3PCI )

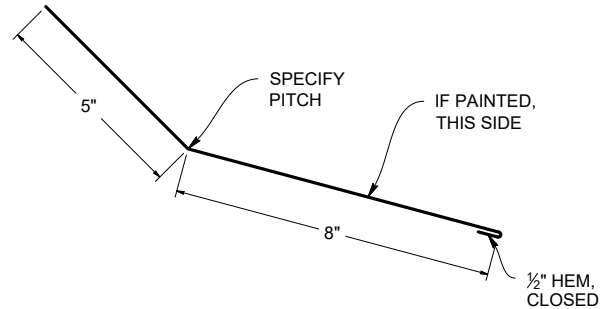

SCALE 1:5

S.O. 13.5"

WEIGHT: 10.2 LBS.

## ALTERNATE INSIDE PITCH CHANGE ( T3APCI )

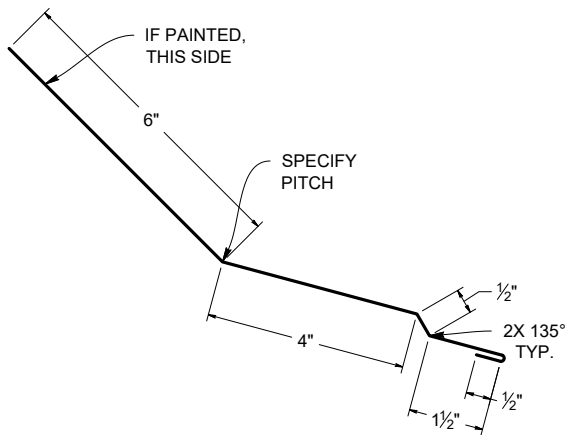

SCALE 1:4

S.O. 12.5"

WEIGHT: 6.9 LBS.

## OUTSIDE PITCH CHANGE ( T3PCO )

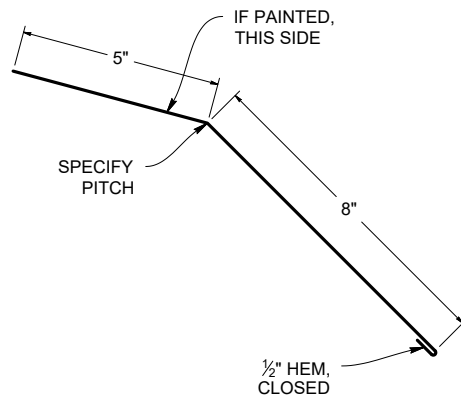

SCALE 1:5

S.O. 13.5"

WEIGHT: 10.2 LBS.

## ENDWALL ( T3EW )

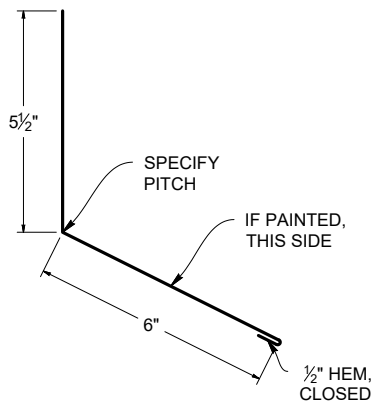

SCALE 1:5

S.O. 12"

WEIGHT: 9 LBS.

## ALTERNATE ENDWALL ( T3AEW )

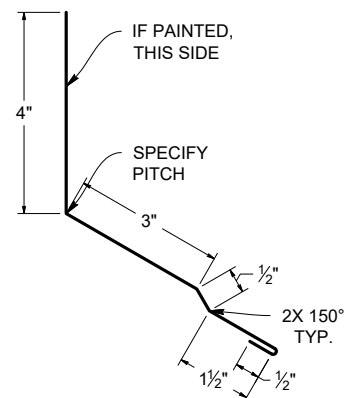

SCALE 1:4

S.O. 9.5"

WEIGHT: 5.4 LBS.

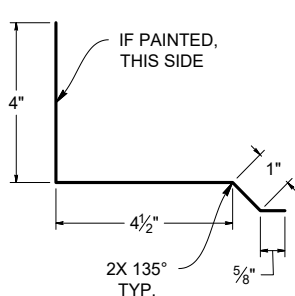
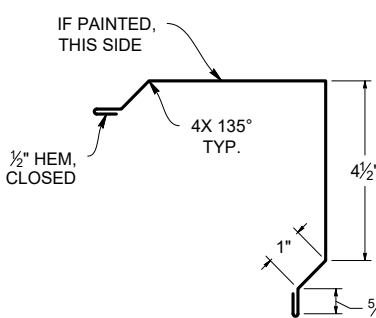
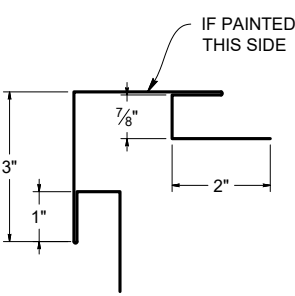
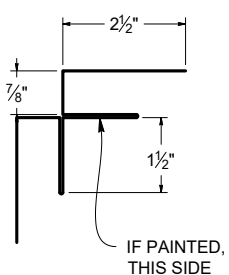
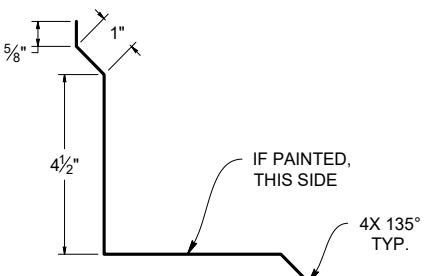
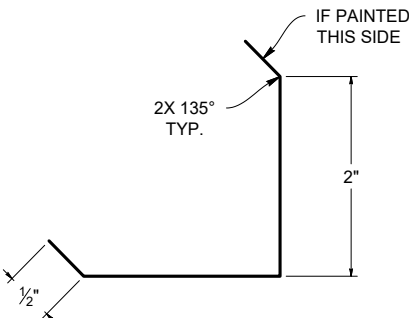
<p><b>.75" SIDEWALL ( T3SW )</b></p>  <p>SCALE 1:5      S.O. 10.125"      WEIGHT: 7.5 LBS.</p>	<p><b>.75" OUTSIDE CORNER ( T3CO )</b></p>  <p>SCALE 1:5      S.O. 13.25"      WEIGHT: 9.2 LBS.</p>
<p><b>.75" OUTSIDE CORNER POST ( T3CPO )</b></p>  <p>SCALE 1:4      S.O. 13.75"      WEIGHT: 10.3 LBS.</p>	<p><b>.75" INSIDE CORNER POST ( T3CPI )</b></p>  <p>SCALE 1:4      S.O. 12.75"      WEIGHT: 9.6 LBS.</p>
<p><b>.75" INSIDE CORNER ( T3CI )</b></p>  <p>SCALE 1:5      S.O. 12.25"      WEIGHT: 9 LBS.</p>	<p><b>.75" MINI CORNER ( T3MC )</b></p>  <p>SCALE 1:2      S.O. 5"      WEIGHT: 9.2 LBS.</p>

# Through Fastener Flashing Selections

Tuff Rib, T3, GR-7, GR-5

Standard: 29/26GA: 12'6, 24GA:10'



## .75" BASE FLASHING ( T3BF )

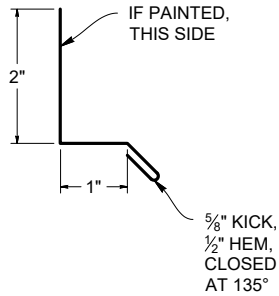

SCALE 1:3

S.O. 4.125"

WEIGHT: 3 LBS.

## .75" Z-FLASHING ( T3ZF )

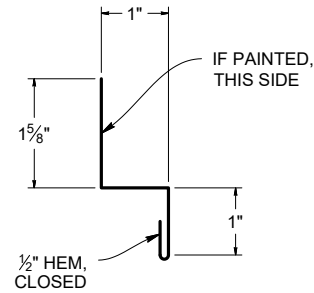

SCALE 1:3

S.O. 4.125"

WEIGHT: 3.2 LBS.

## .75" C-FLASHING ( T3CF )

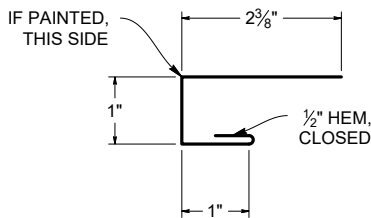

SCALE 1:3

S.O. 4.875"

WEIGHT: 3.7 LBS.

## .75" VERTICAL JAMB TRIM ( T3VJT )

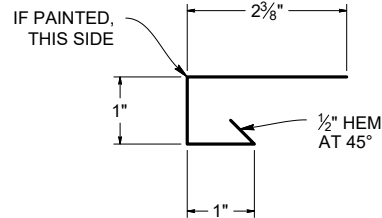

SCALE 1:3

S.O. 4.875"

WEIGHT: 3.7 LBS.

## .75 SOFFIT C-FLASHING ( T3SCF )

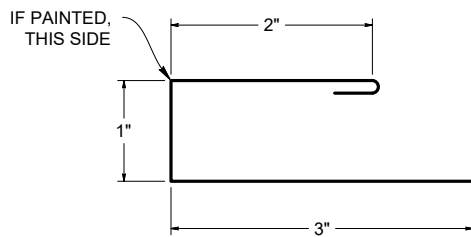

SCALE 1:2

S.O. 6.5"

WEIGHT: 9.2 LBS.

## DOOR EDGE ( T3DE )

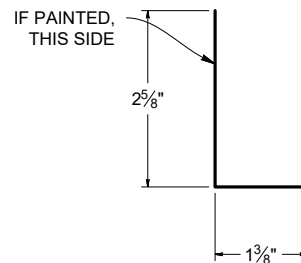

SCALE 1:3

S.O. 4"

WEIGHT: 3 LBS.

**DOOR JAMB 4.625" TO 7.5"  
( T3DJ5 )**

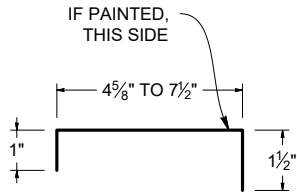

SCALE 1:5                      S.O. VARIES                      WEIGHT: 5.3 LBS.

**DOOR JAMB 7.625" TO 9.5"  
( T3DJ7 )**

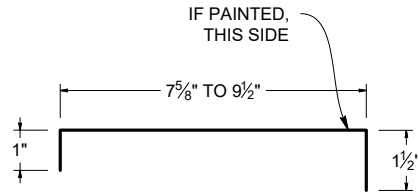

SCALE 1:5                      S.O. VARIES                      WEIGHT: 7.6 LBS.

**DOOR JAMB 9.625" TO 11.5"  
( T3DJ9 )**

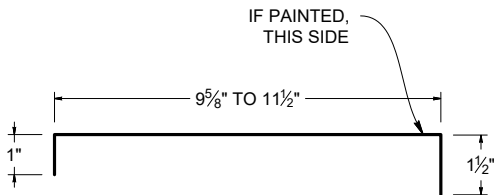

SCALE 1:5                      S.O. VARIES                      WEIGHT: 9.1 LBS.

**OPEN JAMB 4.625" TO 7.5"  
( T3OJ5 )**

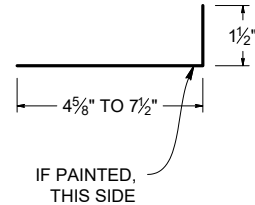

SCALE 1:5                      S.O. VARIES                      WEIGHT: 4.6 LBS.

**OPEN JAMB 7.625" TO 9.5"  
( T3OJ7 )**

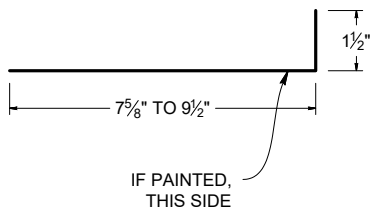

SCALE 1:5                      S.O. VARIES                      WEIGHT: 6.8 LBS.

**OPEN JAMB 9.625" TO 11.5"  
( T3OJ9 )**

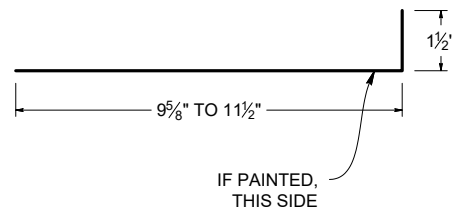

SCALE 1:5                      S.O. VARIES                      WEIGHT: 8.3 LBS.

# Through Fastener Flashing Selections

Tuff Rib, T3, GR-7, GR-5

Standard: 29/26GA: 12'6, 24GA:10'



<p><b>.75" FASCIA TRIM 5-5/8" ( T3FT5 )</b></p> <p>SCALE 1:4                      S.O. 8.375"                      WEIGHT: 6.8 LBS.</p>	<p><b>.75" FASCIA TRIM 7-5/8" ( T3FT7 )</b></p> <p>SCALE 1:4                      S.O. 10.375"                      WEIGHT: 8.4 LBS.</p>
<p><b>.75" FASCIA TRIM 9-5/8" ( T3FT9 )</b></p> <p>SCALE 1:5                      S.O. 12.375"                      WEIGHT: 10.1 LBS.</p>	<p><b>.75" GRAVEL STOP ( T3GRS )</b></p> <p>SCALE 1:2                      S.O. 5.375"                      WEIGHT: 6.9 LBS.</p>
<p><b>.75" STYLE D ( T3SD )</b></p> <p>SCALE 1:2                      S.O. 6"                      WEIGHT: 6.9 LBS.</p>	<p><b>SINGLE TRACK COVER (FACEMOUNT) ( T3TCS )</b></p> <p>SCALE 1:5                      S.O. 12"                      WEIGHT: 9 LBS.</p>

### SINGLE TRACK COVER (STUDMOUNT) ( T3TCSCB )

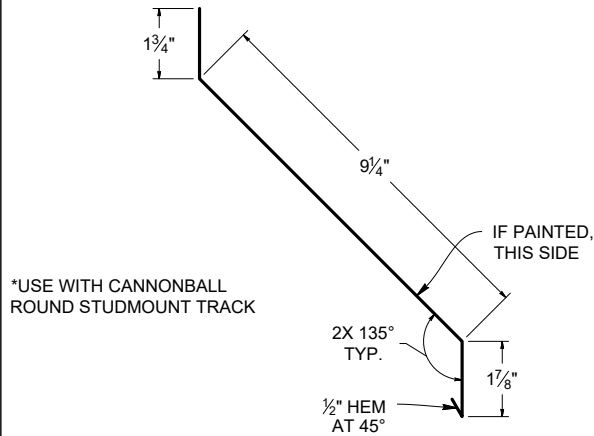

SCALE 1:5      S.O. 13.375"      WEIGHT: 10 LBS.

### DOUBLE TRACK COVER (STUDMOUNT) ( T3TCDCB )

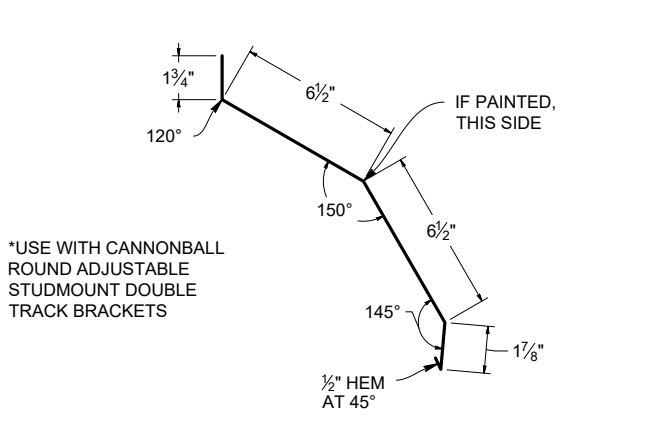

SCALE 1:8      S.O. 17.125"      WEIGHT: 12.9 LBS.

### .75 SINGLE TRACK COVER ( T3ATCS )

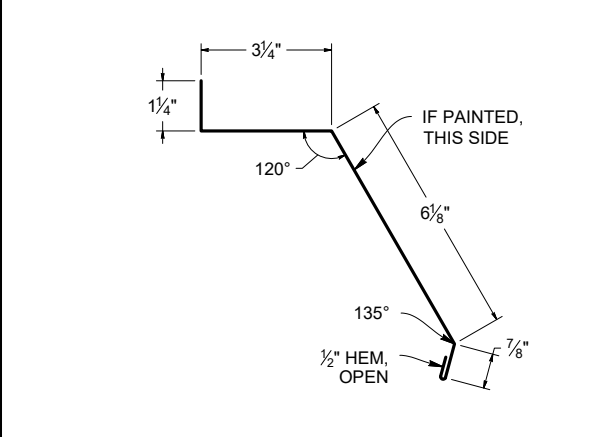

SCALE 1:5      S.O. 12"      WEIGHT: 6.9 LBS.

### DOUBLE TRACK COVER ( T3ATCD )

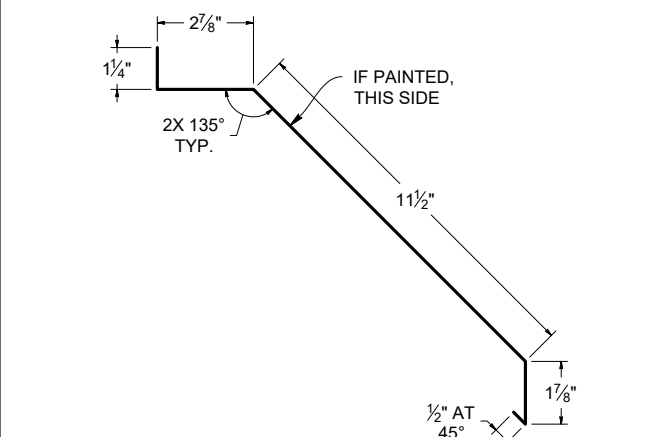

SCALE 1:6      S.O. 18"      WEIGHT: 6.9 LBS.

### .75" DOOR OPENING ( T3DO )

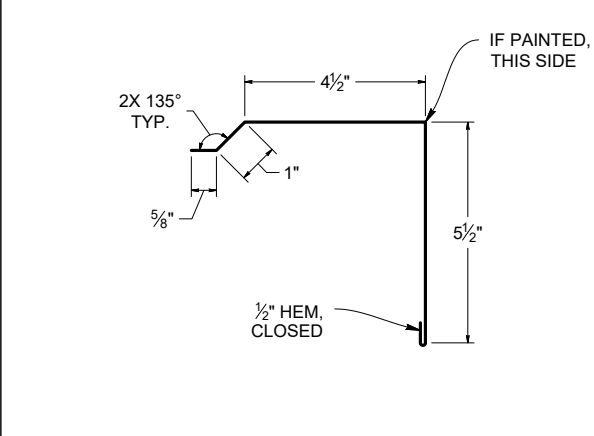

SCALE 1:5      S.O. 12.125"      WEIGHT: 9 LBS.

### 1.5" X 5.5" SPECIAL RAKE ( T3CR1S )

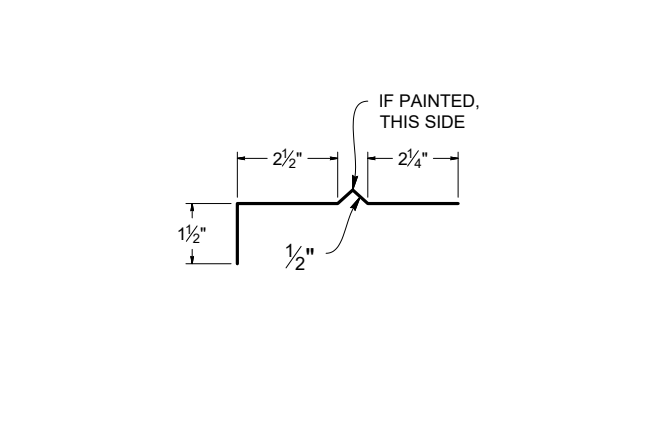

SCALE 1:5      S.O. 7.25"      WEIGHT: 5.4 LBS.

# Through Fastener Flashing Selections

Tuff Rib, T3, GR-7, GR-5

Standard: 29/26GA: 12'6", 24GA:10'



## 1.5" X 7" SPECIAL RAKE ( T3CR7S )

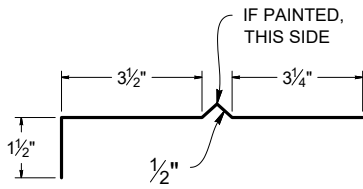

SCALE 1:5

S.O. 9.25"

WEIGHT: 6.9 LBS.

## .75 RSP SNOW BREAK ( T3RSB )

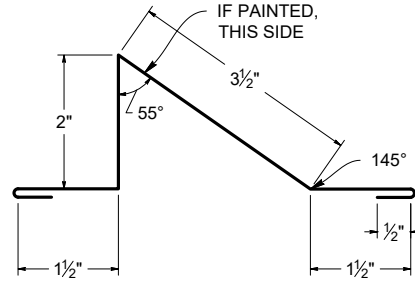

SCALE 1:3

S.O. 9.5"

WEIGHT: 6.9 LBS.

## .75" DOOR RAIL COVER ( T3DRC )

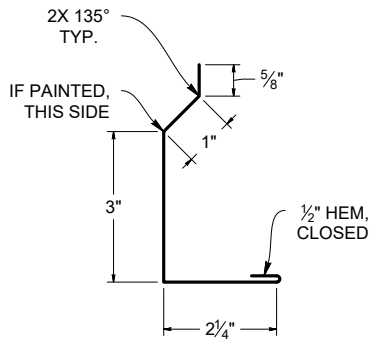

SCALE 1:4

S.O. 7.375"

WEIGHT: 5.6 LBS.

## BOX GUTTER ( T3BG )

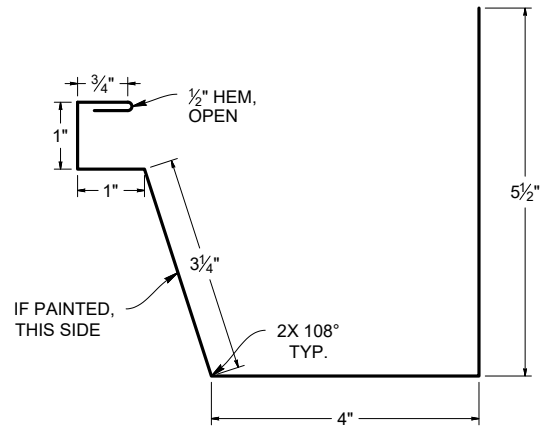

SCALE 1:3

S.O. 16"

WEIGHT: 13.1 LBS.

## GUTTER HANGER ( AGH6 )

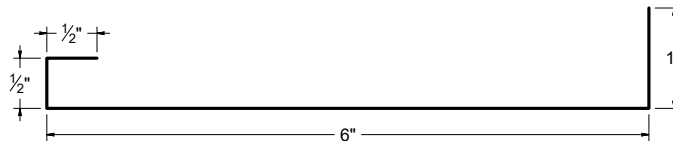

S.O. 8"

WEIGHT: 0.5 LBS.

SCALE 1:2

**STANDARD EAVE  
( PBRES )**

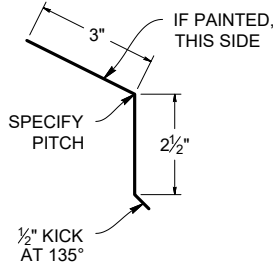

SCALE 1:5

S.O. 6"

WEIGHT: 4.5 LBS.

**4" EAVE  
( PBRE4 )**

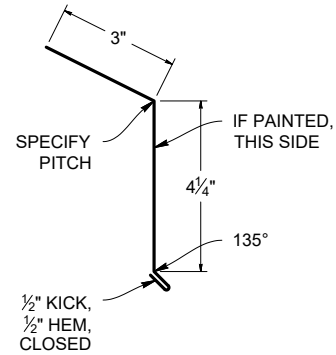

SCALE 1:5

S.O. 8.25"

WEIGHT: 6.3 LBS.

**2X6 STEP EAVE  
( PBRSE6 )**

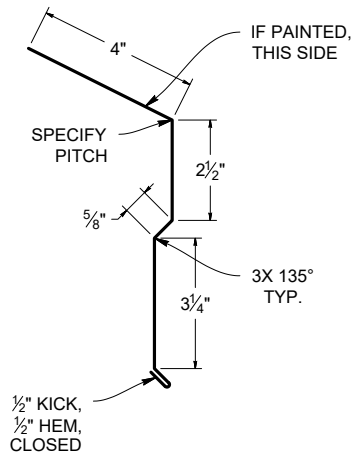

SCALE 1:5

S.O. 11.375"

WEIGHT: 10.1 LBS.

**PBR STANDARD GABLE  
( PBRGS )**

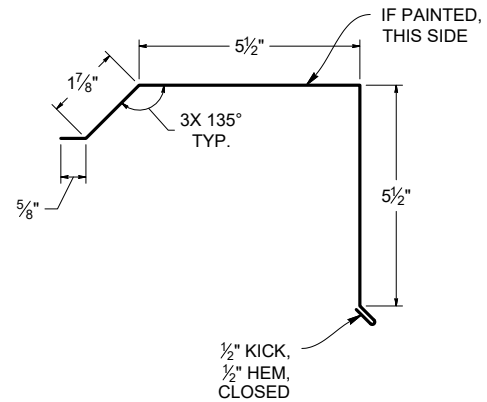

SCALE 1:5

S.O. 14.5"

WEIGHT: 10.8 LBS.

**PBR 2X6 STEP GABLE  
( PBRSG6 )**

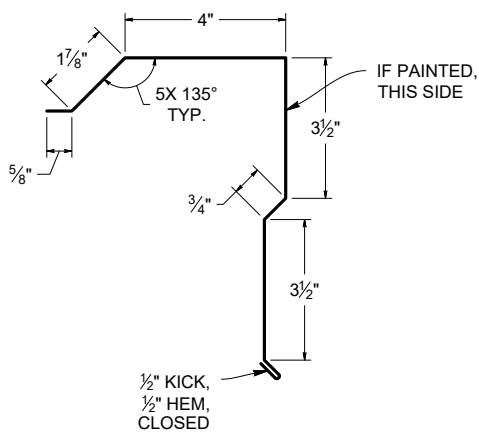

SCALE 1:5

S.O. 15.25"

WEIGHT: 11.3 LBS.

**PBR BULL NOSE GABLE  
( PBRGBN )**

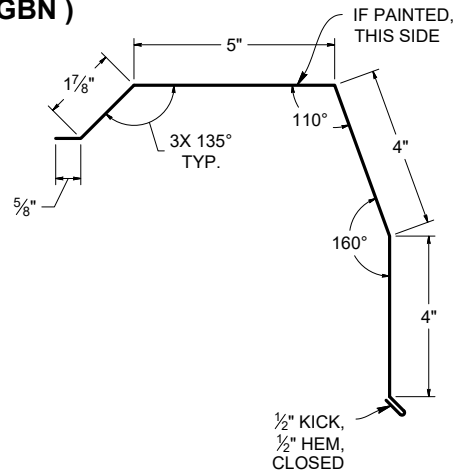

SCALE 1:5

S.O. 16.5"

WEIGHT: 12.3 LBS.

# Through Fastener Flashing Selections

PBR/Marion R

Standard: 29/26GA: 12'6", 24GA:10'

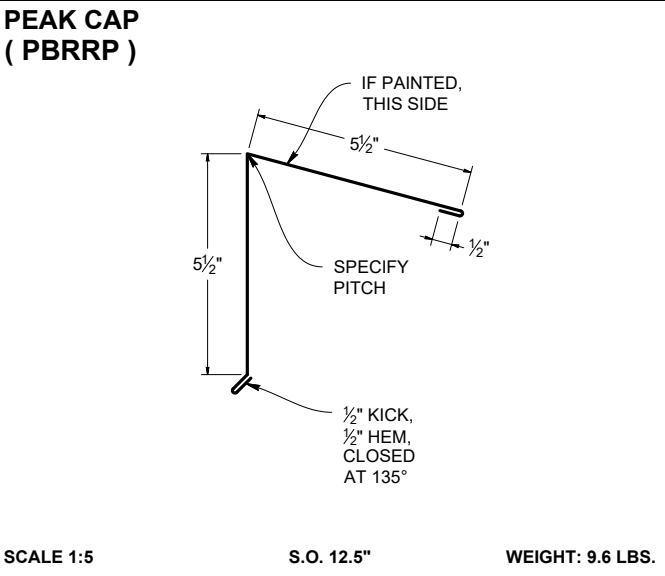
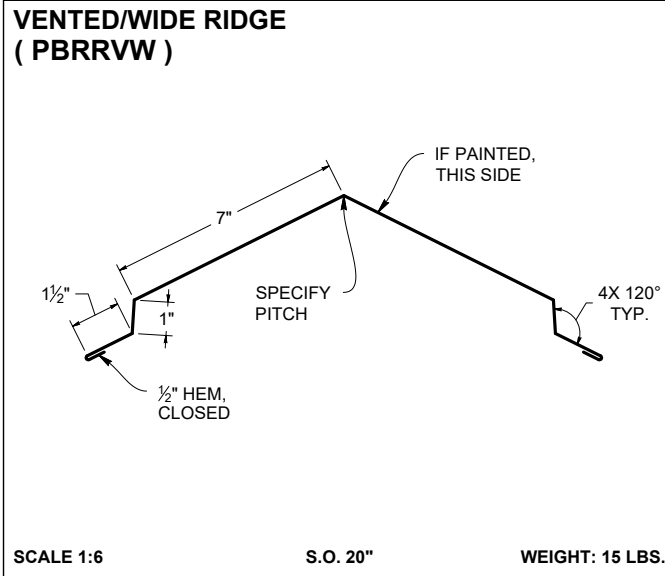
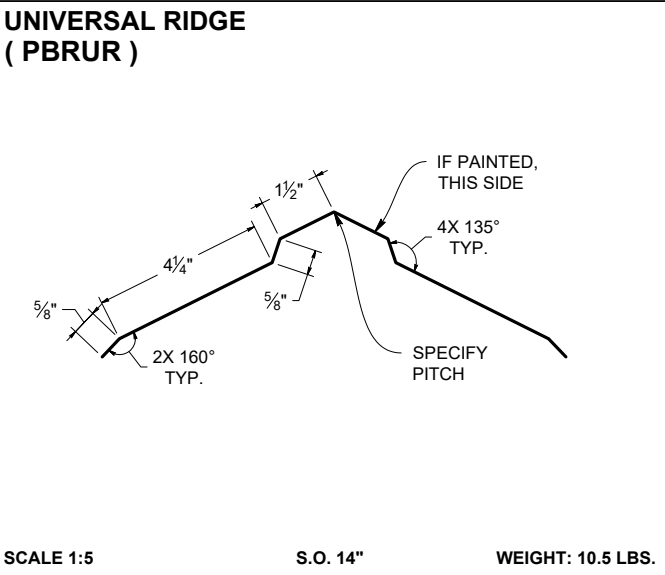
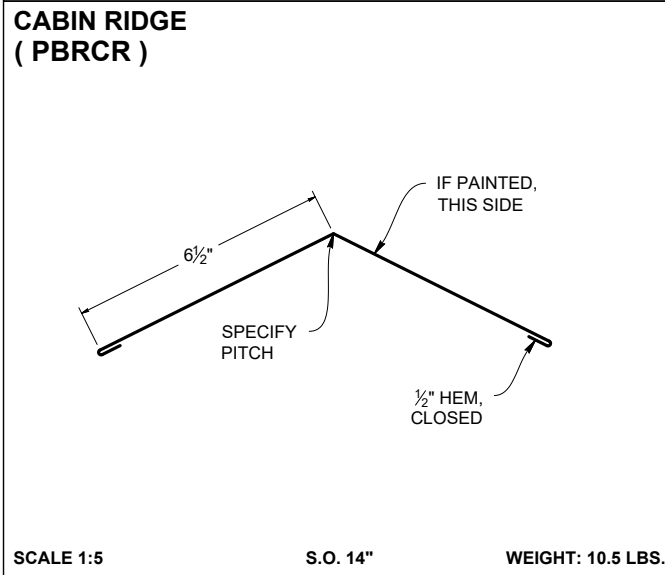
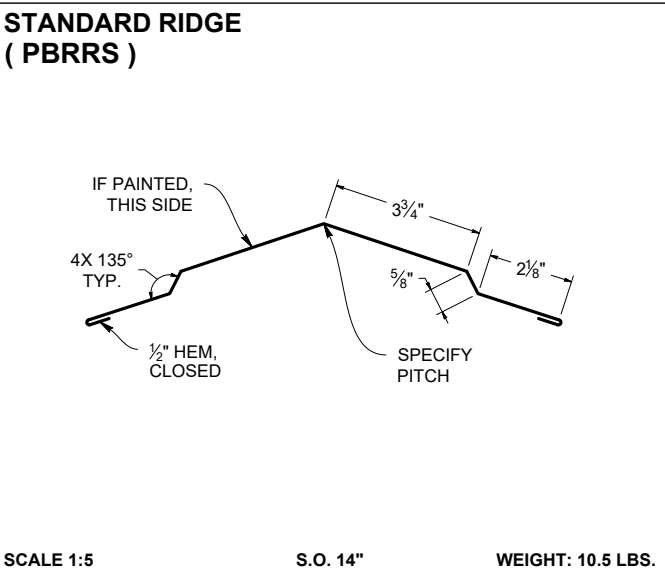
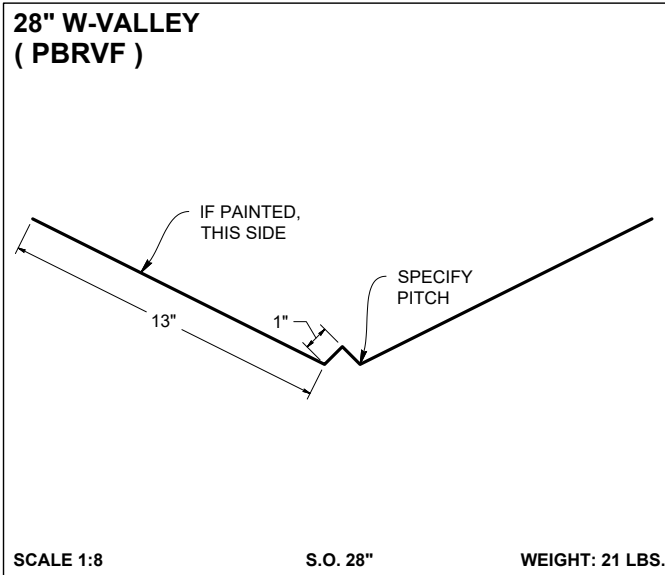

## PBR FORMED RIDGE ( TPBRFR )

\*PITCH CAN ONLY BE 3:12  
AND UNDER

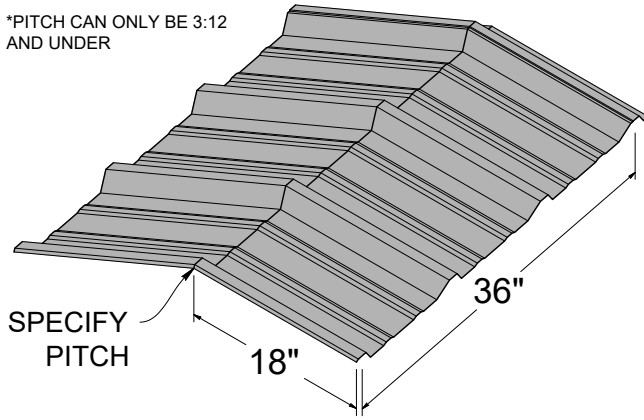

SCALE 1:2

LENGTH: VARIES

WEIGHT:

## OUTSIDE PITCH CHANGE ( PBRPCO )

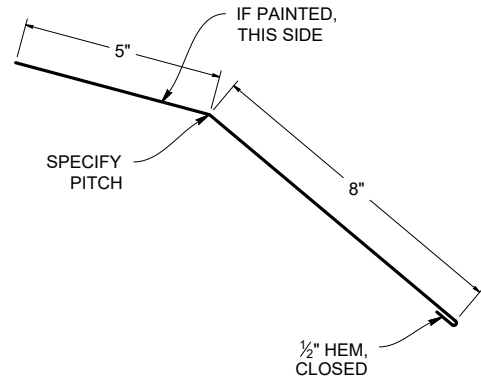

SCALE 1:5

S.O. 13.5"

WEIGHT: 10.2 LBS.

## ALTERNATE PITCH CHANGE ( PBRAPCI )

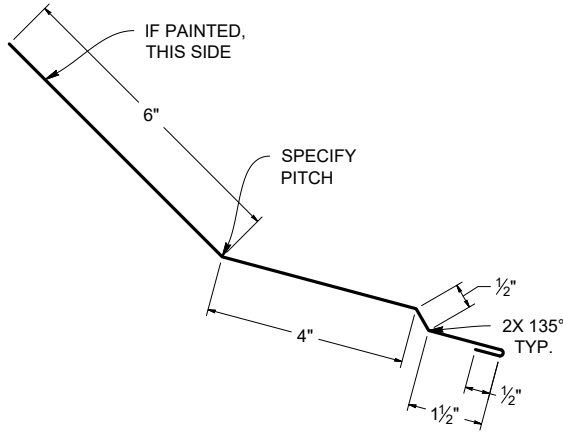

SCALE 1:4

S.O. 12.5"

WEIGHT: 12.9 LBS.

## INSIDE PITCH CHANGE ( PBRPCI )

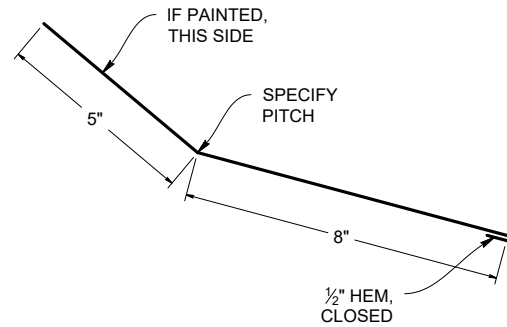

SCALE 1:5

S.O. 13.5"

WEIGHT: 10.2 LBS.

## PBR OUTSIDE CORNER ( PBRCO )

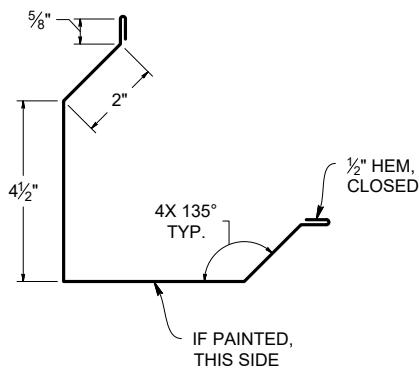

SCALE 1:5

S.O. 15.25"

WEIGHT: 10.9 LBS.

## PBR INSIDE CORNER ( PBRICI )

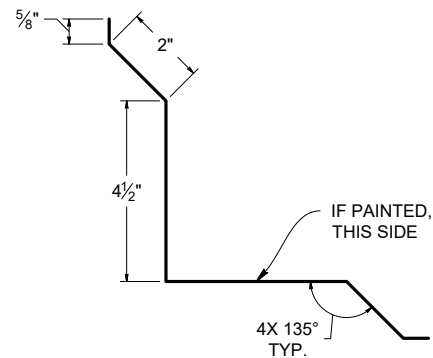

SCALE 1:5

S.O. 14.25"

WEIGHT: 10.5 LBS.

# Through Fastener Flashing Selections

PBR/Marion R

Standard: 29/26GA: 12'6, 24GA:10'



## ENDWALL (PBREW)

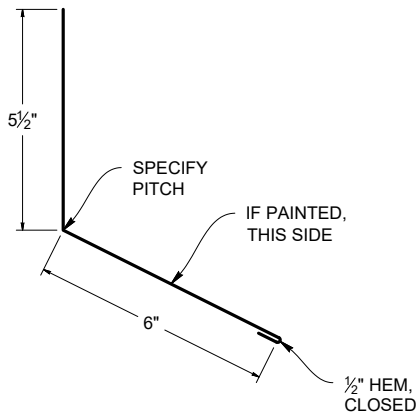

SCALE 1:5                      S.O. 12"                      WEIGHT: 9 LBS.

## PBR SIDEWALL (PBRSW)

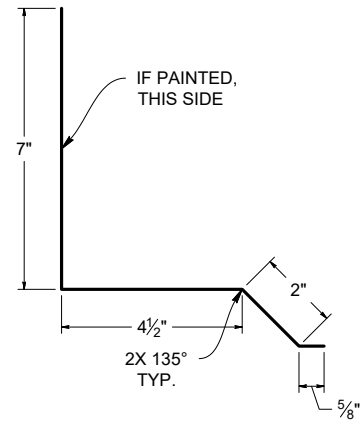

SCALE 1:5                      S.O. 14.125"                      WEIGHT: 10.5 LBS.

## PBR Z-FLASHING (PBRZF)

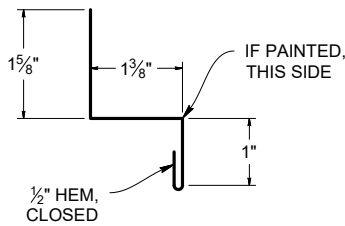

SCALE 1:3                      S.O. 4.5"                      WEIGHT: 3.5 LBS.

## PBR BASE FLASHING (PBRBF)

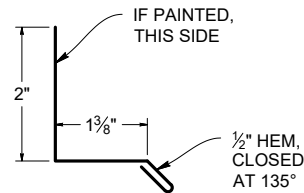

SCALE 1:3                      S.O. 4.375"                      WEIGHT: 3.4 LBS.

## PBR C-FLASHING (PBRCF)

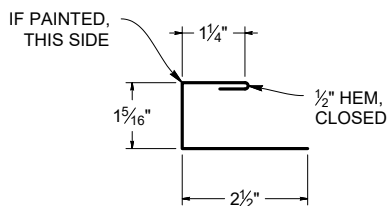

SCALE 1:4                      S.O. 5.5625"                      WEIGHT: 4.2 LBS.

## PBR VERTICAL JAMB TRIM (PBRVJT)

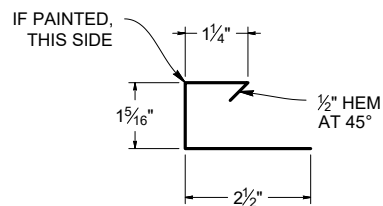

SCALE 1:4                      S.O. 5.5625"                      WEIGHT: 4.2 LBS.

**PBR OUTSIDE CORNER POST  
( PBRCP0 )**

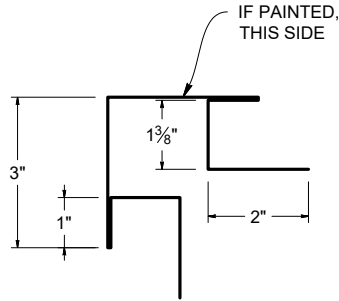

SCALE 1:4 S.O. 14.75" WEIGHT: 11 LBS.

**PBR INSIDE CORNER POST  
( PBRCP1 )**

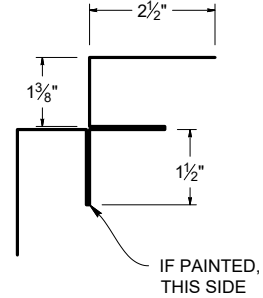

SCALE 1:4 S.O. 13.75" WEIGHT: 10.3 LBS.

**DOOR JAMB 4.625" TO 7.5"  
( PBRDJ5 )**

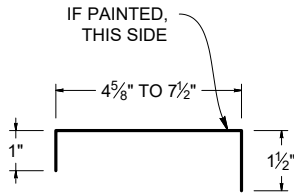

SCALE 1:5 S.O. VARIES WEIGHT: 5.34 LBS.

**DOOR JAMB 7.625" TO 9.5"  
( PBRDJ7 )**

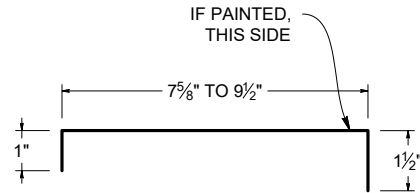

SCALE 1:5 S.O. VARIES WEIGHT: 7.6 LBS.

**DOOR JAMB 9.625" TO 11.5"  
( PBRDJ9 )**

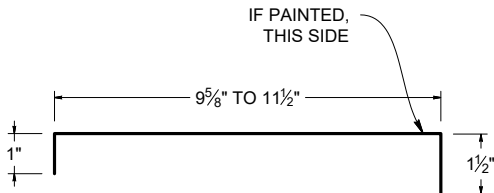

SCALE 1:5 S.O. VARIES WEIGHT: 9.1 LBS.

**OPEN JAMB 4.625" TO 7.5"  
( PBROJ5 )**

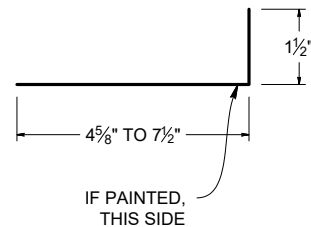

SCALE 1:4 S.O. VARIES WEIGHT: 4.6 LBS.

# Through Fastener Flashing Selections

PBR/Marion R

Standard: 29/26GA: 12'6, 24GA:10'



## OPEN JAMB 7.625" TO 9.5" ( PBROJ7 )

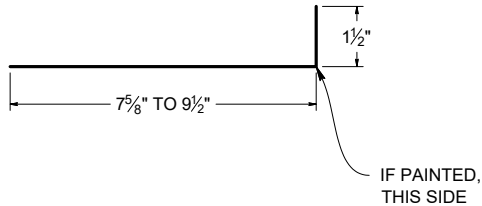

SCALE 1:5 S.O. VARIES WEIGHT: 6.8 LBS.

## OPEN JAMB 9.625" TO 11.5" ( PBROJ9 )

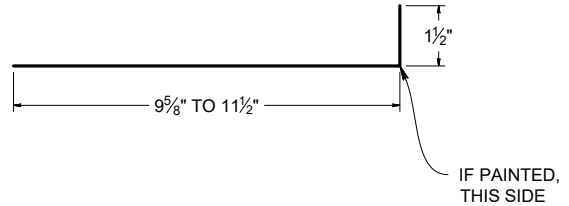

SCALE 1:5 S.O. VARIES WEIGHT: 8.3 LBS.

## SINGLE TRACK COVER (FACEMOUNT) ( PBRTCS )

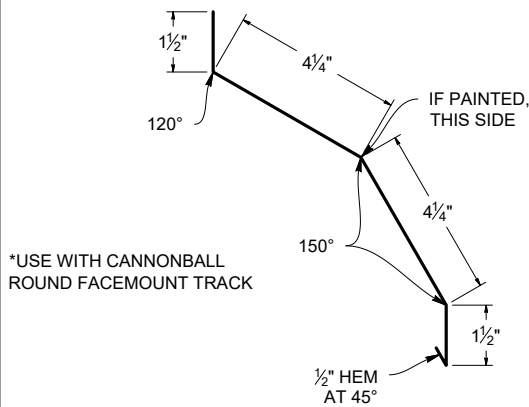

SCALE 1:5 S.O. 12" WEIGHT: 9 LBS.

## CANNON BALL SINGLE TRACK (STUDMOUNT) ( PBRTCSCB )

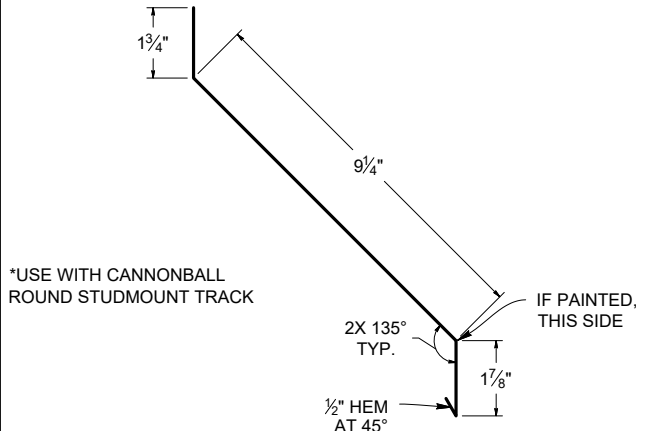

SCALE 1:5 S.O. 13.375" WEIGHT: 10.1 LBS.

## CANNON BALL DOUBLE TRACK (STUDMOUNT) ( PBRTDCB )

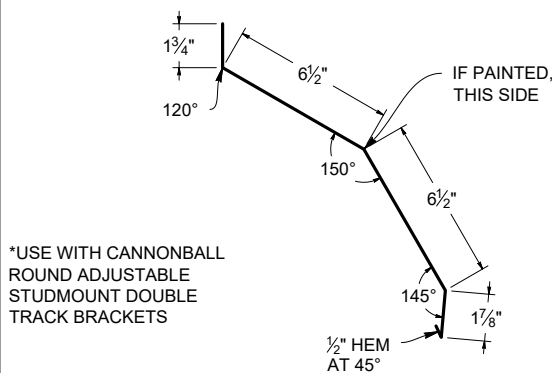

SCALE 1:8 S.O. 17.125" WEIGHT: 12.9 LBS.

## PBR DOOR OPENING TRIM ( PBRDO )

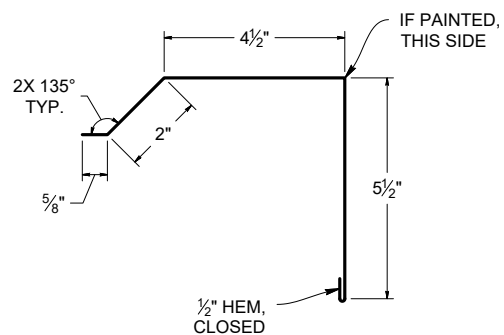

SCALE 1:5 S.O. 13.125" WEIGHT: 9.7 LBS.

**DOOR EDGE  
( PBRDE )**

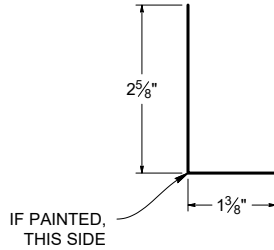

SCALE 1:3

S.O. 4"

WEIGHT: 3 LBS.

**PBR DOOR RAIL COVER  
( PBRDRC )**

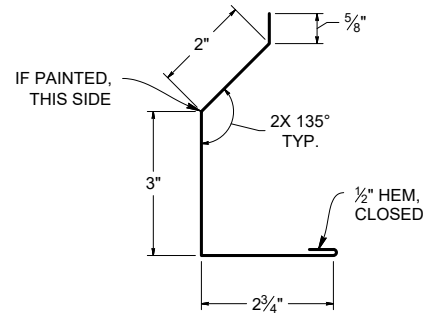

SCALE 1:4

S.O. 8.875"

WEIGHT: 6.6 LBS.

**BOX GUTTER  
( PBRBG )**

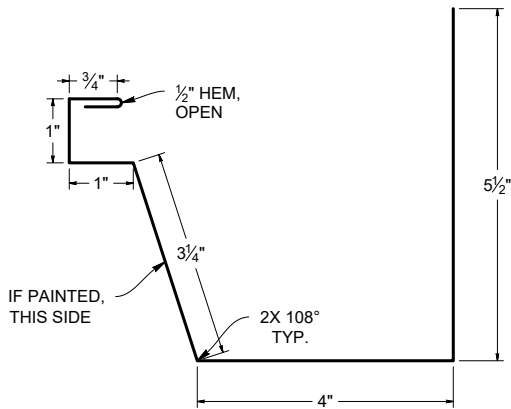

SCALE 1:3

S.O. 16"

WEIGHT: 13.3 LBS.

**GUTTER HANGER  
( AGH6 )**

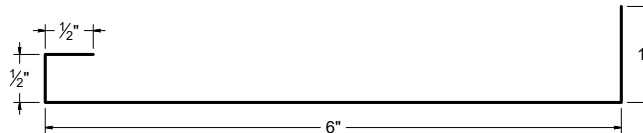

S.O. 8"

WEIGHT: 0.5 LBS.

SCALE 1:2

# Through Fastener Flashing Selections

Max Corr, 2 1/2" Corrugated

Standard: 29/26GA: 12'6, 24GA:10'



## STANDARD EAVE ( 2CES )

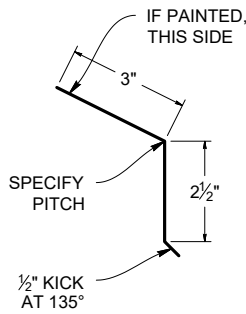

SCALE 1:5

S.O. 6"

WEIGHT: 4.5 LBS.

## CORRUGATED GABLE ( 2CGS )

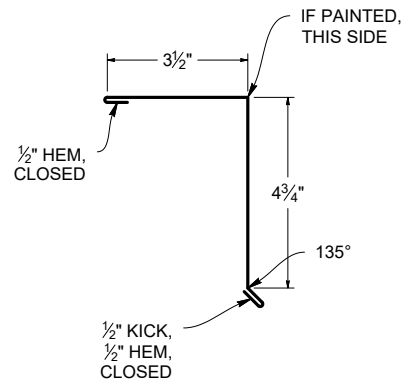

SCALE 1:5

S.O. 9.75"

WEIGHT: 7.3 LBS.

## PEAK CAP ( 2CRP )

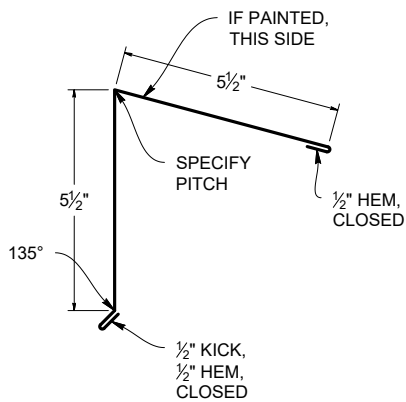

SCALE 1:5

S.O. 12.5"

WEIGHT: 9.6 LBS.

## 28" W-VALLEY ( 2CVF )

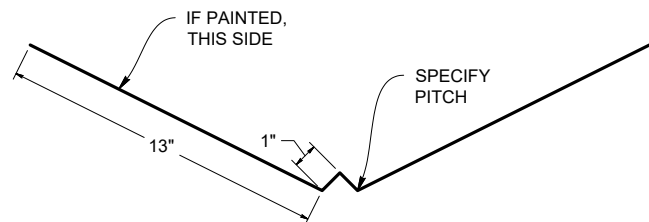

SCALE 1:8

S.O. 28"

WEIGHT: 21 LBS.

## CORRUGATED ENDWALL ( 2CEW )

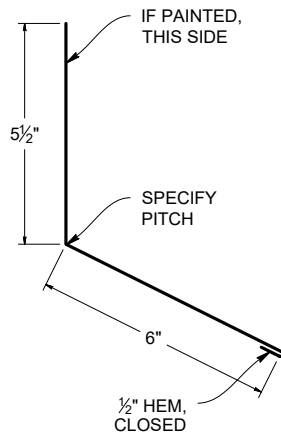

SCALE 1:5

S.O. 12"

WEIGHT: 9 LBS.

## CORRUGATED SIDEWALL ( 2CSW )

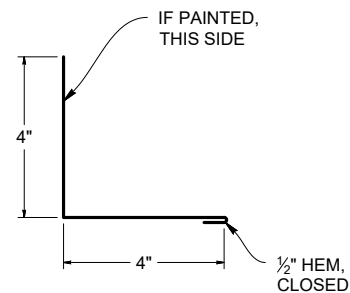

SCALE 1:5

S.O. 8.5"

WEIGHT: 6.5 LBS.

## STANDARD RIDGE ( 2CRS )

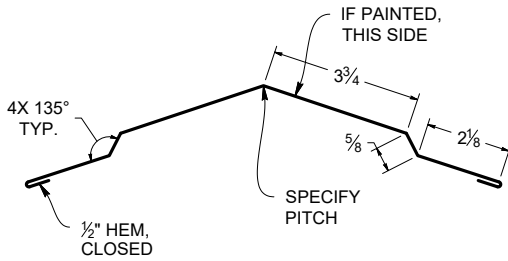

SCALE 1:5

S.O. 14"

WEIGHT: 10.5 LBS.

## VENTED/WIDE RIDGE ( 2CRVW )

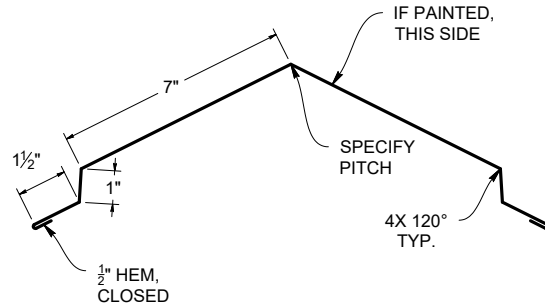

SCALE 1:6

S.O. 20"

WEIGHT: 15 LBS.

## CABIN RIDGE ( 2CCR )

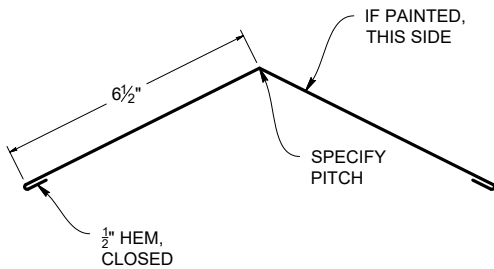

SCALE 1:5

S.O. 14"

WEIGHT: 10.5 LBS.

## CORRUGATED C-FLASHING ( 2CCF )

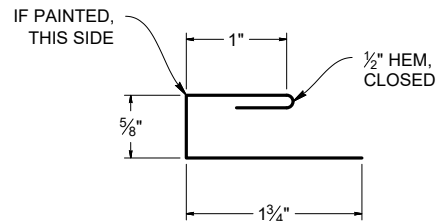

SCALE 1:2

S.O. 3.875"

WEIGHT: 2.9 LBS.

## CORRUGATED VERTICAL JAMB TRIM ( 2CVJT )

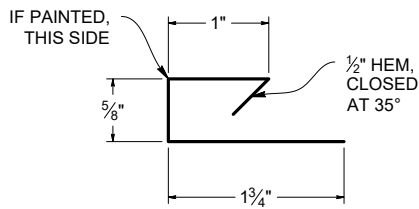

SCALE 1:2

S.O. 3.875"

WEIGHT: 2.9 LBS.

## CORRUGATED Z-FLASHING ( 2CZF )

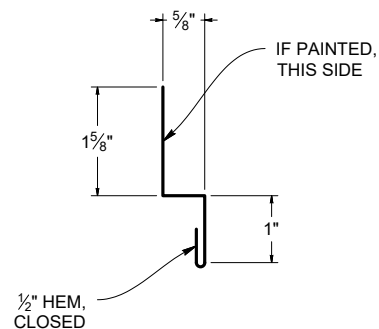

SCALE 1:3

S.O. 3.75"

WEIGHT: 2.8 LBS.

# Through Fastener Flashing Selections

Max Corr, 2 1/2" Corrugated  
Standard: 29/26GA: 12'6, 24GA:10'



## CORRUGATED OUTSIDE CORNER POST (2CCPO)

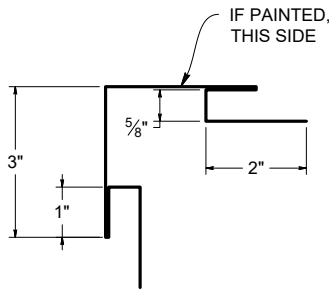

SCALE 1:4 S.O. 13.25" WEIGHT: 9.9 LBS.

## CORRUGATED INSIDE CORNER POST (2CCPI)

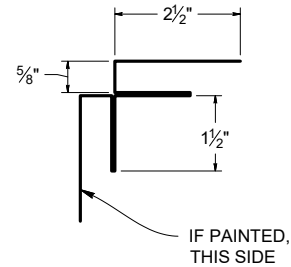

SCALE 1:4 S.O. 12.25" WEIGHT: 9.2 LBS.

## INSIDE PITCH CHANGE (2CPCI)

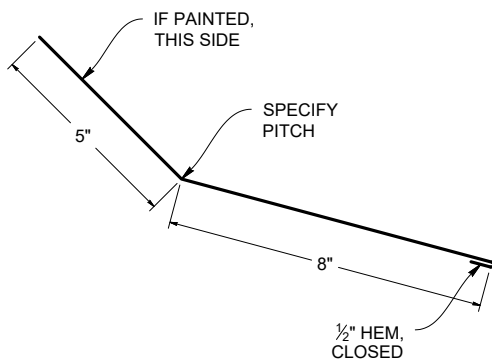

SCALE 1:5 S.O. 13.5" WEIGHT: 10.2 LBS.

## OUTSIDE PITCH CHANGE (2CPCO)

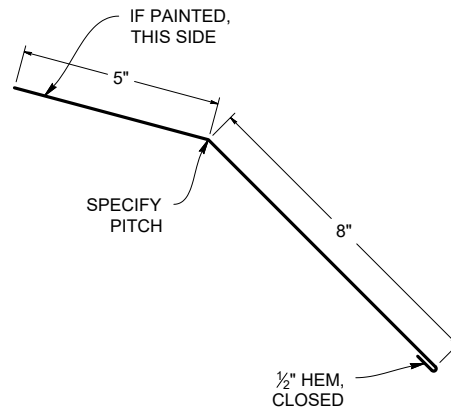

SCALE 1:5 S.O. 13.5" WEIGHT: 10.2 LBS.

## CORRUGATED OUTSIDE CORNER (2CCO)

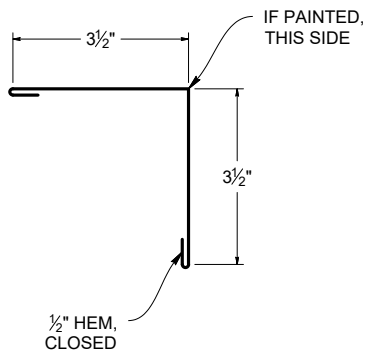

SCALE 1:4 S.O. 8" WEIGHT: 6 LBS.

## CORRUGATED INSIDE CORNER (2CCI)

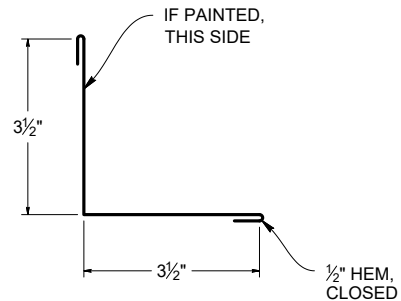

SCALE 1:4 S.O. 8" WEIGHT: 6 LBS.

**.75" CORRUGATED BASE METAL FLASHING  
( 2CBF )**

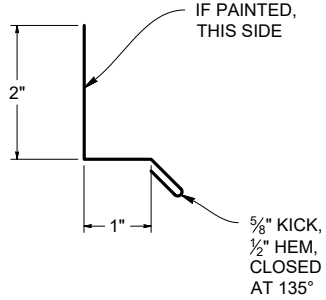

SCALE 1:3

S.O. 4.125"

WEIGHT: 3 LBS.

**BOX GUTTER  
( 2CBG )**

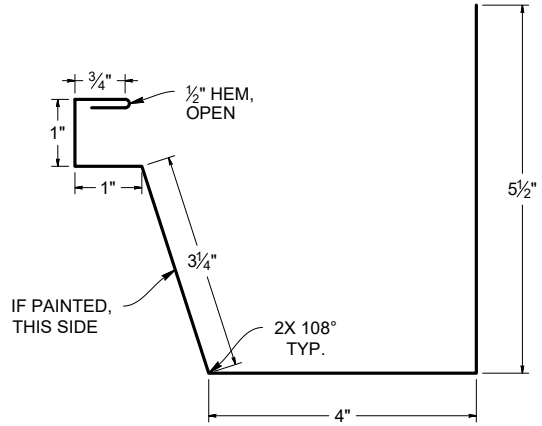

SCALE 1:3

S.O. 16"

WEIGHT: 13.3 LBS.

**GUTTER HANGER  
( AGH6 )**

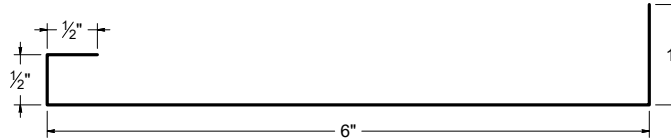

S.O. 8"

WEIGHT: 0.5 LBS.

SCALE 1:2

# Through Fastener Flashing Selections

Classic 7/8 Corrugated

Standard: 29/26GA: 12'6", 24GA:10'



## CLASSIC CORRUGATED EAVE ( CCES )

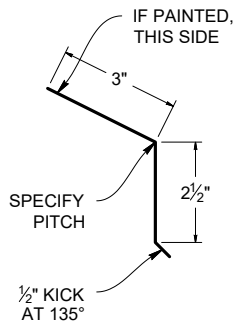

SCALE 1:5 S.O. 6" WEIGHT: 4.5 LBS.

## CLASSIC CORRUGATED GABLE ( CCGS )

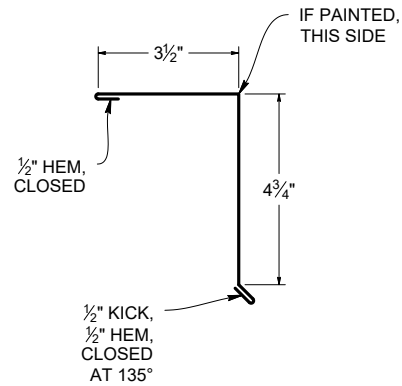

SCALE 1:5 S.O. 9.75" WEIGHT: 7.1 LBS.

## STANDARD RIDGE ( CCRS )

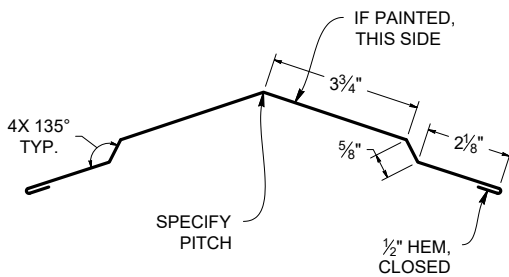

SCALE 1:5 S.O. 14" WEIGHT: 10.5 LBS.

## VENTED/WIDE RIDGE ( CCRVW )

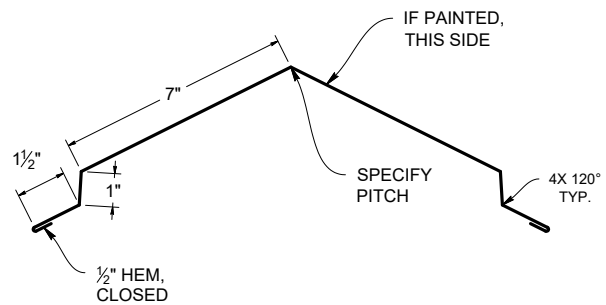

SCALE 1:6 S.O. 20" WEIGHT: 15 LBS.

## CABIN RIDGE ( CCCR )

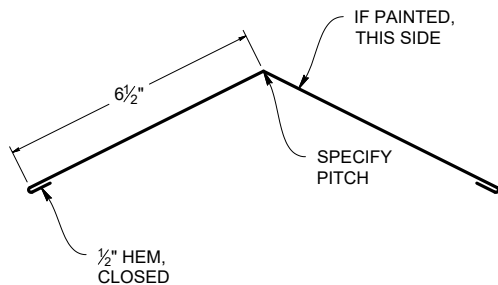

SCALE 1:5 S.O. 14" WEIGHT: 10.5 LBS.

## 28" W-VALLEY ( CCVF )

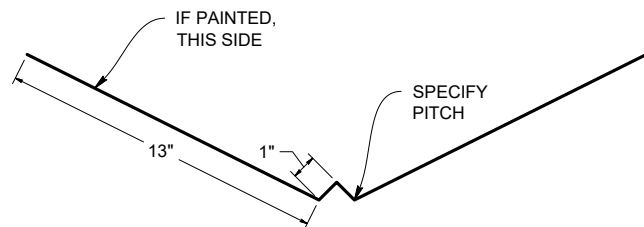

SCALE 1:8 S.O. 28" WEIGHT: 21 LBS.

**CLASSIC CORRUGATED OUTSIDE CORNER POST (CCCPO)**

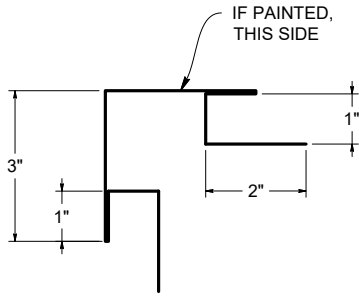

SCALE 1:4 S.O. 14" WEIGHT: 10.5 LBS.

**CLASSIC CORRUGATED INSIDE CORNER POST (CCCPI)**

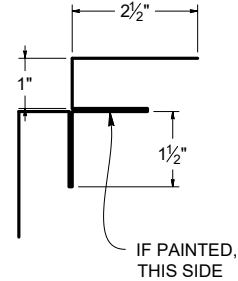

SCALE 1:4 S.O. 13" WEIGHT: 9.8 LBS.

**INSIDE PITCH CHANGE (CCPCI)**

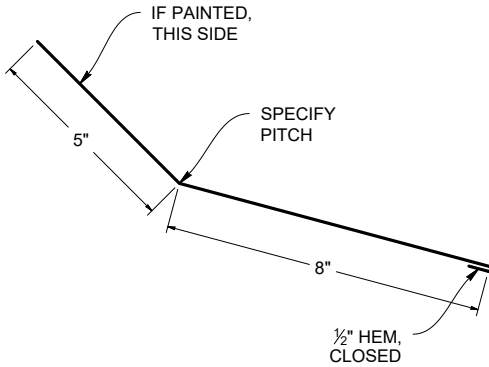

SCALE 1:5 S.O. 13.5" WEIGHT: 10.2 LBS.

**OUTSIDE PITCH CHANGE (CCPCO)**

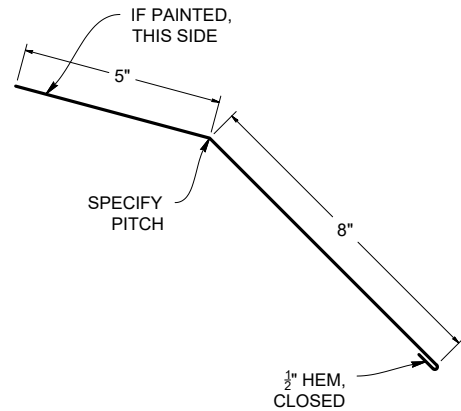

SCALE 1:5 S.O. 13.5" WEIGHT: 10.2 LBS.

**CLASSIC CORRUGATED OUTSIDE CORNER (CCCO)**

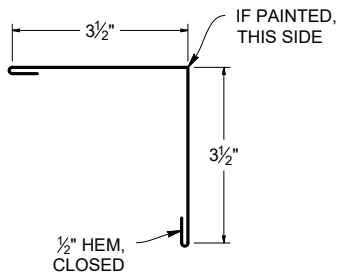

SCALE 1:4 S.O. 8" WEIGHT: 6 LBS.

**CLASSIC CORRUGATED INSIDE CORNER (CCCI)**

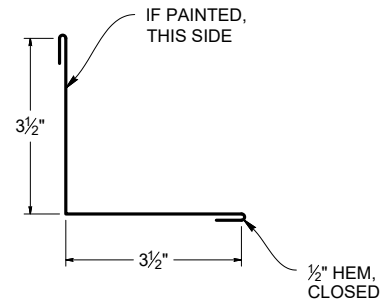

SCALE 1:4 S.O. 8" WEIGHT: 6 LBS.

# Through Fastener Flashing Selections

Classic 7/8 Corrugated

Standard: 29/26GA: 12'6, 24GA:10'



## CLASSIC CORRUGATED ENDWALL ( CCEW )

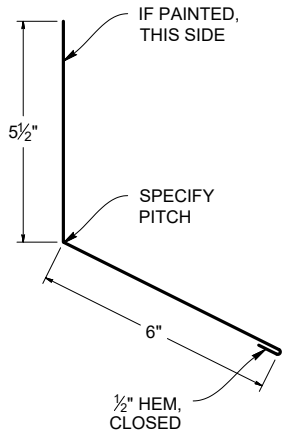

SCALE 1:5 S.O. 12" WEIGHT: 9 LBS.

## CLASSIC CORRUGATED SIDEWALL ( CCSW )

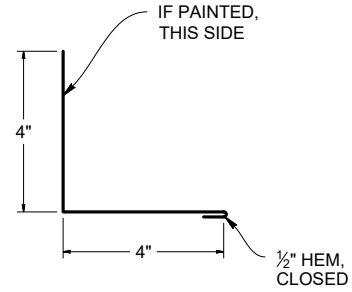

SCALE 1:5 S.O. 8.5" WEIGHT: 6.5 LBS.

## CLASSIC CORRUGATED BASE METAL ( CCBF )

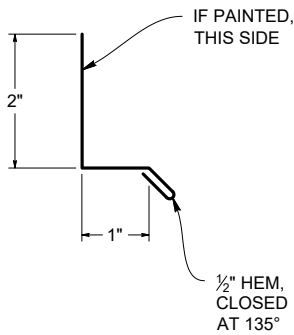

SCALE 1:3 S.O. 4" WEIGHT: 3 LBS.

## CLASSIC CORRUGATED Z-FLASHING ( CCZF )

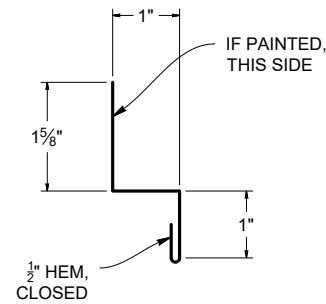

SCALE 1:3 S.O. 4.125" WEIGHT: 3.2 LBS.

## CLASSIC CORRUGATED C-CASING ( CCCF )

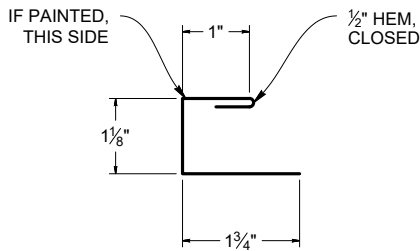

SCALE 1:3 S.O. 4.375" WEIGHT: 3.3 LBS.

## CLASSIC CORRUGATED VERTICAL JAMB TRIM ( CCVJT )

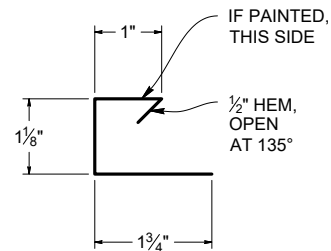

SCALE 1:3 S.O. 4.375" WEIGHT: 3.3 LBS.

## PEAK CAP ( CCRP )

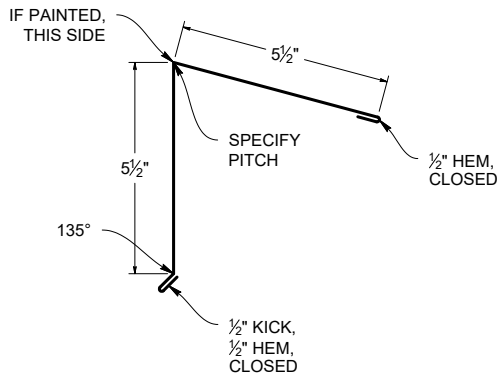

SCALE 1:5

S.O. 12.5"

WEIGHT: 9.6 LBS.

## BOX GUTTER ( CCBG )

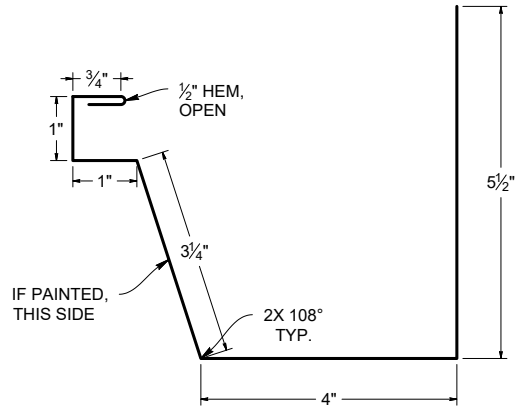

SCALE 1:3

S.O. 16"

WEIGHT: 13.3 LBS.

## GUTTER HANGER ( AGH6 )

S.O. 8"

WEIGHT: 0.5 LBS.

SCALE 1:2

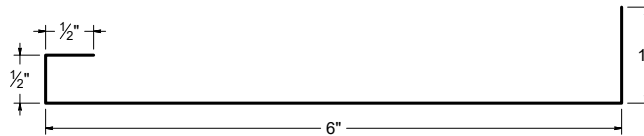

# Through Fastener Flashing Selections

HR34

Standard: 29/26GA: 12'6, 24GA:10'



## HR-34 STANDARD EAVE ( HRES )

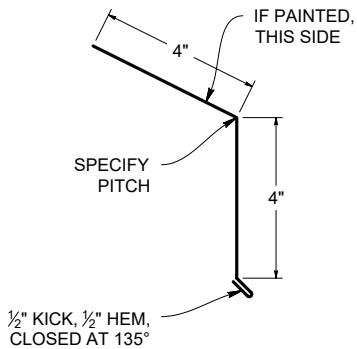

SCALE 1:5      S.O. 9"      WEIGHT: 6.8 LBS.

## HR-34 GABLE ( HRGS )

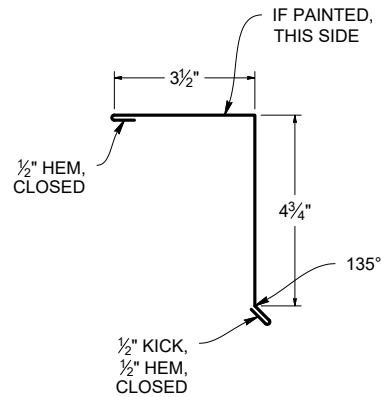

SCALE 1:5      S.O. 9.75"      WEIGHT: 7.2 LBS.

## HR-34 GABLE B ( HRGSB )

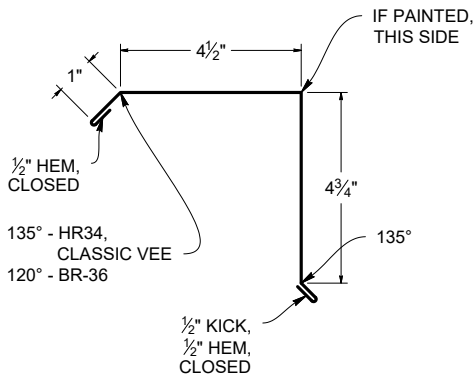

SCALE 1:5      S.O. 11.75"      WEIGHT: 8.8 LBS.

## STANDARD RIDGE ( HRRS )

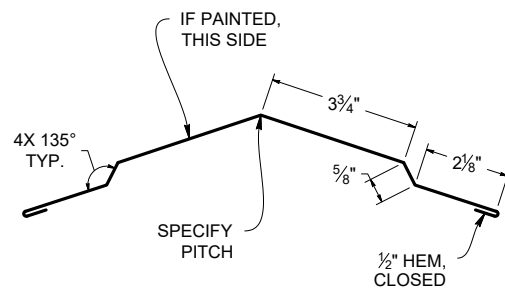

SCALE 1:5      S.O. 14"      WEIGHT: 10.5 LBS.

## VENTED/WIDE RIDGE ( HRRVW )

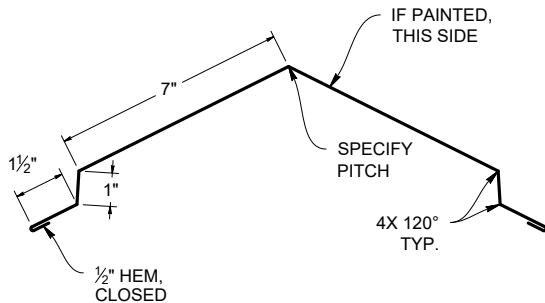

SCALE 1:6      S.O. 20"      WEIGHT: 15 LBS.

## CABIN RIDGE ( HRCR )

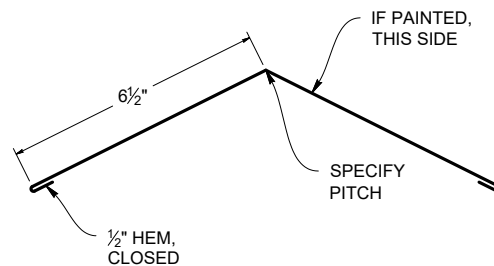

SCALE 1:5      S.O. 14"      WEIGHT: 10.5 LBS.

**28" W-VALLEY  
( HRVF )**

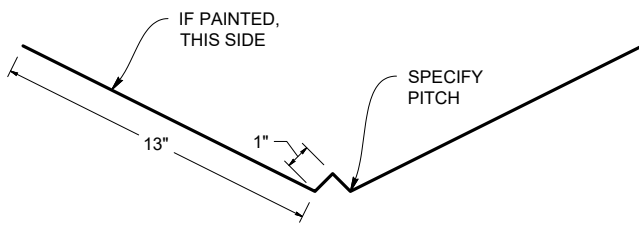

SCALE 1:8                      S.O. 28"                      WEIGHT: 21 LBS.

**HR-34 PEAK CAP  
( HRRP )**

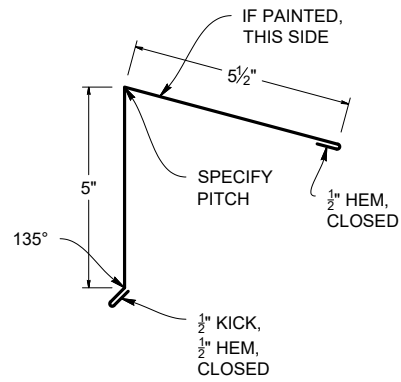

SCALE 1:5                      S.O. 12"                      WEIGHT: 9 LBS.

**HR-34 OUTSIDE CORNER POST  
( HRCPO )**

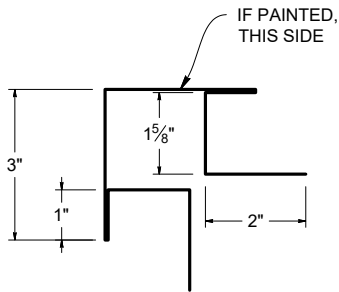

SCALE 1:4                      S.O. 15.25"                      WEIGHT: 11.4 LBS.

**HR-34 INSIDE CORNER POST  
( HRCPI )**

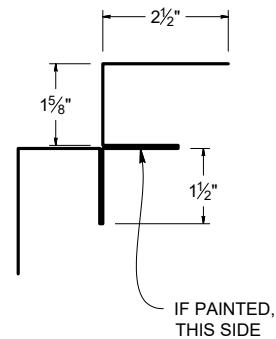

SCALE 1:4                      S.O. 14.25"                      WEIGHT: 10.7 LBS.

**INSIDE PITCH CHANGE  
( HRPCI )**

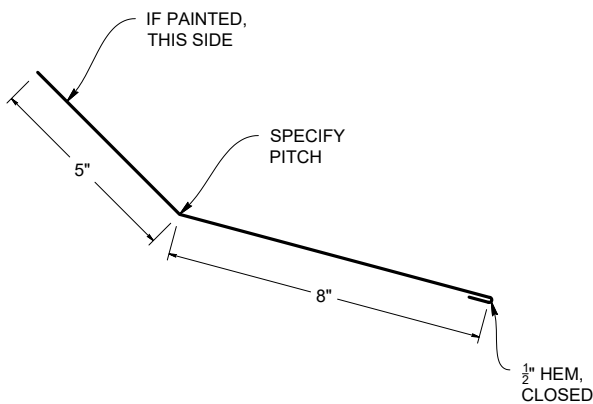

SCALE 1:5                      S.O. 13.5"                      WEIGHT: 10.1 LBS.

**OUTSIDE PITCH CHANGE  
( HRPCO )**

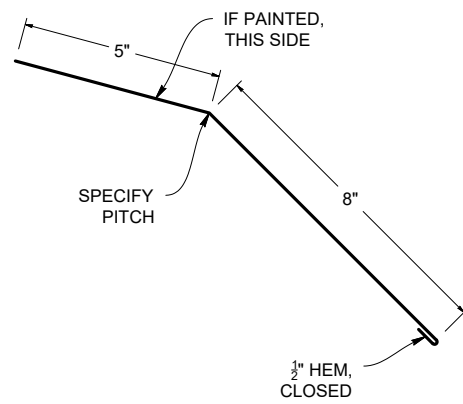

SCALE 1:5                      S.O. 13.5"                      WEIGHT: 10.1 LBS.

# Through Fastener Flashing Selections

HR34

Standard: 29/26GA: 12'6, 24GA:10'



## HR-34 OUTSIDE CORNER (HRCO)

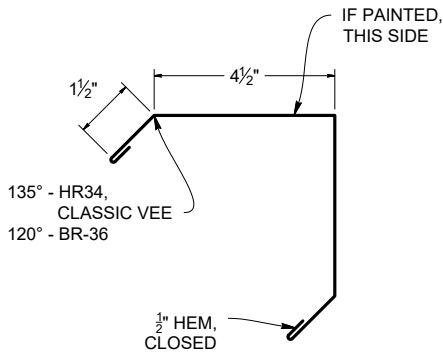

SCALE 1:5

S.O. 13"

WEIGHT: 9.8 LBS.

## HR-34 INSIDE CORNER (HRCI)

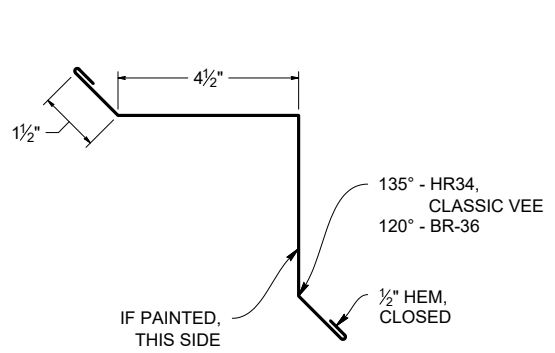

SCALE 1:5

S.O. 13"

WEIGHT: 9.8 LBS.

## HR-34 ENDWALL (HREW)

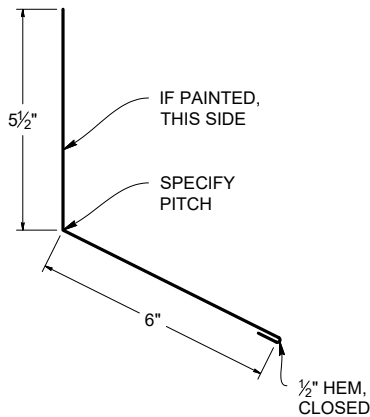

SCALE 1:5

S.O. 9.5"

WEIGHT: 7.1 LBS.

## HR-34 SIDEWALL (HRSW)

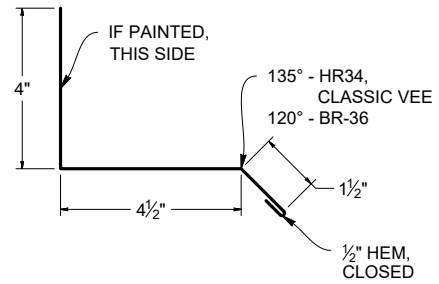

SCALE 1:5

S.O. 10.5"

WEIGHT: 7.9 LBS.

## HR-34 BASE FLASHING (HRBF)

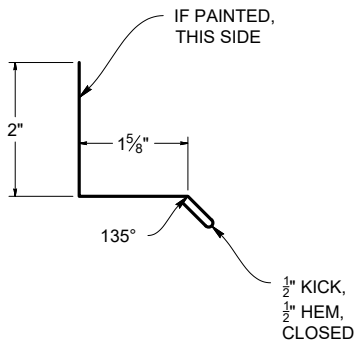

SCALE 1:3

S.O. 4.625"

WEIGHT: 3.5 LBS.

## HR-34 Z-FLASHING (HRZF)

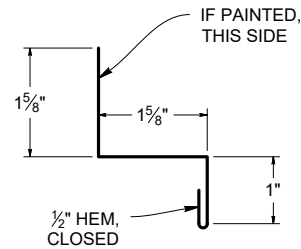

SCALE 1:3

S.O. 4.75"

WEIGHT: 3.6 LBS.

**HR-34 C-FLASHING  
( HRCF )**

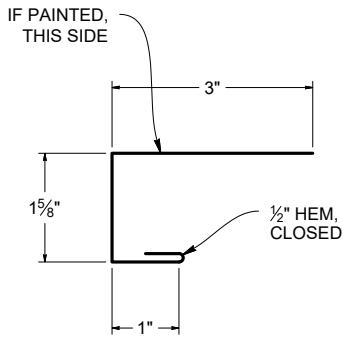

SCALE 1:3

S.O. 6.125"

WEIGHT: 4.5 LBS.

**HR-34 4" PERFORATED STRIP  
( HRPS )**

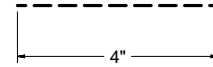

SCALE 1:4

S.O. 4"

WEIGHT: 3 LBS.

**BOX GUTTER  
( HRBG )**

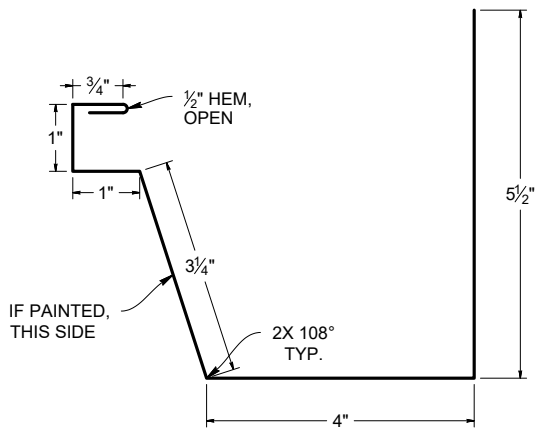

SCALE 1:3

S.O. 16"

WEIGHT: 13.3 LBS.

**GUTTER HANGER  
( AGH6 )**

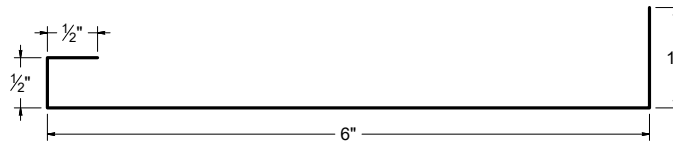





S.O. 8"

WEIGHT: 0.5 LBS.

SCALE 1:2

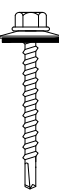
# Through Fastener Accessories

FASTENER	DESCRIPTION	Size	Quantity	
	<b>#10 Woodfast Screw:</b> Metal to wood, use for panel attachment to dimensional lumber. 1/4" Hex head with washer. Available in painted and galvanized.	10 x 1"	250/Bag	3,000/Box
		10 x 1-1/2"	250/Bag	2,500/Box
		(available upon request) 10 x 2"	250/Bag	2,000/Box
	<b>#14 Woodfast Screw:</b> Metal to wood, use for panel attachment to dimensional lumber. 5/16" Hex head with washer. Available in painted and galvanized.	14 x 1"	250/Bag	2,500/Box
		(available upon request) 14 x 1-1/2"	250/Bag	2,000/Box
	<b>#12 Stitch Screw:</b> Metal to metal, use for trim to panel, trim to trim and side lap attachment. 1/4" Hex head with washer. Available in painted and galvanized.	12 x 13/4"	250/Bag	3,000/Box
	<b>#12 Tek Screw:</b> Metal to metal, use for panel attachment to metal purlins. 5/16" Hex head with washer. Available in painted and galvanized.	12 x 1"	250/Bag	2,500/Box
		12 x 1-1/2"	250/Bag	2,000/Box
		(available upon request) 12 x 2"	250/Bag	1,500/Box
	<b>#14 Tek Screw:</b> Metal to metal, use for trim to panel, trim to trim and side lap attachment. 5/16" Hex head with washer. Available in painted and galvanized.	14 x 7/8"	250/Bag	2,500/Box
	<b>#43 Rivet:</b> Attaching trim to trim and trim to panel.	43 x 1/8"	100/Bag	

\*Please note the illustrations (right) for proper fastener installation to ensure a weather-tight seal.

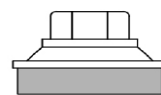

Under Tightened

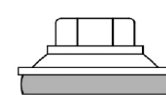

Correctly Tightened

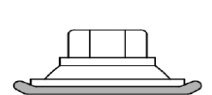

Over Tightened

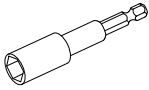
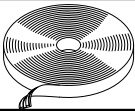
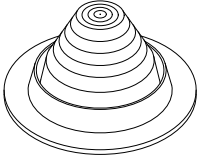
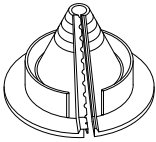
<b>Driver Sockets</b>			
	1/4" Magnetic		
	5/16" Magnetic		
<b>Butyl Mastic Tape</b>		<b>Quantity</b>	
	1/8" x 1/2"		50 feet per roll
	3/32" x 3/4"		50 feet per roll
	<b>Pipe Flashing No.</b>	<b>Temperature Rating: -30°F to 250°F Gray - Standard Round</b>	<b>Temperature Rating: 250°F to 390°F Orange - High Temp.</b>
	#1	1/4" to 2"	-
	#2	1-3/4" to 3-1/4"	-
	#3	1/4" to 3-1/4"	-
	#4	3" to 6"	3" to 6"
	#5	4" to 7"	-
	#6	5" to 9"	5" to 9"
	#7	6" to 11"	6" to 11"
	#8	7" to 13"	7" to 13"
	#9	10" to 18"	10" to 18"
	<b>Pipe Flashing</b>	<b>Gray - Retrofit Round</b>	
	Small	3-1/4" to 2-3/4"	
	Medium	2" to 7-1/4"	
	Large	3-1/4" to 10"	

<b>Closures</b>	
Universal Closure	1" x 1" x 25'
Universal Closure	1-1/2" x 1-1/2" x 25'
Universal Closure	2 x 2 x 25'
T-3, PBR, Tuff Rib, GR7 - Outside Formed Closure (top of panel)	36" coverage
T-3, PBR, Tuff Rib, GR7 - Inside Formed Closure (bottom of panel)	36" coverage
2-1/2" Corrugated, Max Corrugated - Foam Closure	24" coverage
Classic 7/8" Corrugated Foam Closure	37" coverage
HR-34™ Foam Closure	34" coverage
<b>Caulking</b>	
Marco Weather-Tite™ Roof Sealant	available per tube or case
FlexSeal™ Sealant	available per tube or case
<b>Fly Screen</b>	
Ridge Flyscreen - Fiberglass (used for vented ridge - over plywood)	8" x 100' roll
<b>Touch-Up Paint</b>	
Spray Can - Kynar 500® and ArmorTech (all colors)	5.5 oz.
Pen - Kynar 500® (Black, Glacier White, Sterling Grey, Zinc Grey, Charcoal Grey, Forest Green, Tile Red, Medium Bronze, Dark Bronze and Weathered Zinc)	*Special order for other colors
<b>Underlayment</b> - These Underlayments are for roofs requiring plywood sheeting.	
Synthetic Roofing Underlayment	10 square roll
Self-Adhering Underlayment (high temperature)	2 square roll
<b>Insulation</b>	
2" Blanket Insulation (VRR Backed)	6' x 27' roll
2" Blanket Insulation (VRR Backed)	6' x 33' roll
2" Blanket Insulation (VRR Backed)	6' x 39' roll
2" Blanket Insulation (VRR Backed)	6' x 43' roll
2" Blanket Insulation (VRR Backed)	6' x 120' roll
2" Blanket Insulation (VRR Backed)	*Custom length sizes available

<b>Vapor Barrier</b>	
Dura-Skrim®	8' x 65', 8' x 125', 14' x 100', 14' x 155', 14' x 210', and 20' x 100' rolls
<b>Barrier Tape</b>	
Insulation Tape	3" x 150' roll
<b>Polycarbonate Panels</b>	
T-3™ - White & Clear	10', 12', 16,' & 24' (please inquire for custom lengths)
Tuff Rib - White, Clear & ( <i>Smoke: 24' only</i> )	10', 12', 16,' & 24' (please inquire for custom lengths)
PBR - White & Clear	10', 12', & 16' (please inquire for custom lengths)
<b>Fiberglass Panels</b>	
PBR - White	12' & 16' (8oz) (please inquire for custom lengths)
Tuff Rib - White	24' (5oz) (please inquire for custom lengths)
2-1/2" Corrugated - White	12' (8oz) (please inquire for custom lengths)
Classic 7/8" Corrugated™ - White	12' (8oz) (please inquire for custom lengths)
GR-7™ - White	24' (8oz) (please inquire for custom lengths)
<b>Gutter Coil Stock 16-3/4" Maximum - slit to your width (priced per lineal foot)</b> Other 26 & 24 GA gutter coil is available, please inquire.	
Painted 26 GA Grade 50	Charcoal Grey, Sterling Grey, Glacier White, Tile Red, Pine Green, Forest Green, Pacific Blue, and Dark Bronze
Bare 24 GA Grade 55	Zincalume® Plus, AZ-55 ( <i>No finish warranty – 25 yr. perforation warranty</i> )
<b>Flat Stock</b> \$35.00 Pallet Deposite Required	
Painted 29 GA	40-7/8" x 10'
Bare 29 GA	40-7/8" x 10'
Painted 26 GA	43" x 10'
Bare 26 GA	43" x 10'
Painted 24 GA or 22 GA	48" x 10'



Customer Name: \_\_\_\_\_ Job Name: \_\_\_\_\_

Gauge: \_\_\_\_\_ Color: \_\_\_\_\_ Status:  Original  Updated

Specify:  Angles  Color Side  Dimensions  Stretchout \_\_\_\_\_ Customer Initials

S.O. \_\_\_\_\_

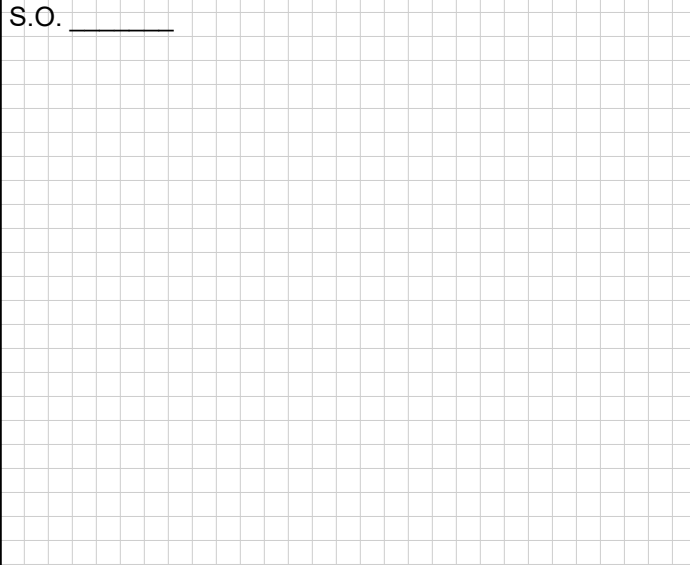

Dwg #: \_\_\_\_\_ Pitch: \_\_\_\_\_ # of Pieces: \_\_\_\_\_

Description: \_\_\_\_\_

Hems:  Open  Closed  Slightly Open

S.O. \_\_\_\_\_

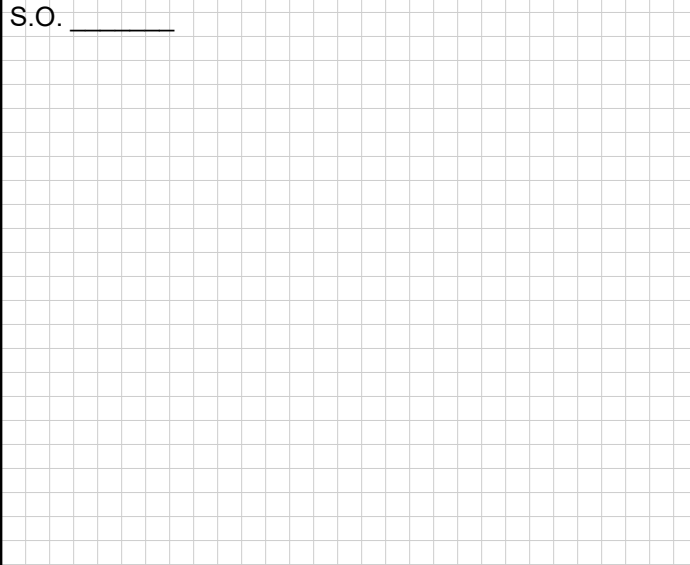

Dwg #: \_\_\_\_\_ Pitch: \_\_\_\_\_ # of Pieces: \_\_\_\_\_

Description: \_\_\_\_\_

Hems:  Open  Closed  Slightly Open

S.O. \_\_\_\_\_

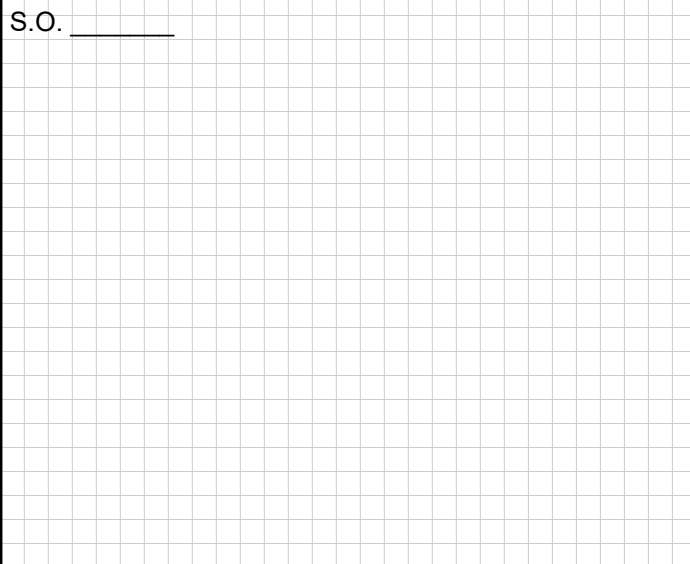

Dwg #: \_\_\_\_\_ Pitch: \_\_\_\_\_ # of Pieces: \_\_\_\_\_

Description: \_\_\_\_\_

Hems:  Open  Closed  Slightly Open

S.O. \_\_\_\_\_

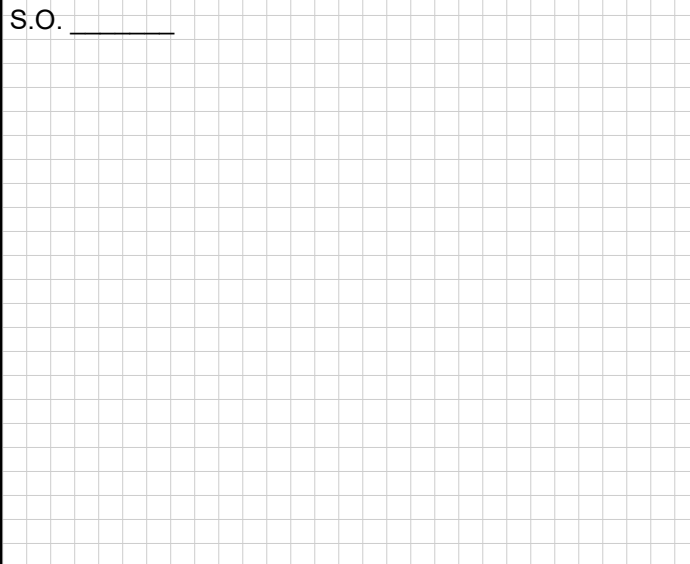

Dwg #: \_\_\_\_\_ Pitch: \_\_\_\_\_ # of Pieces: \_\_\_\_\_

Description: \_\_\_\_\_

Hems:  Open  Closed  Slightly Open

**Please provide a drawing for each flashing with precise measurements and angles**

**Fax to: 503-581-6877**

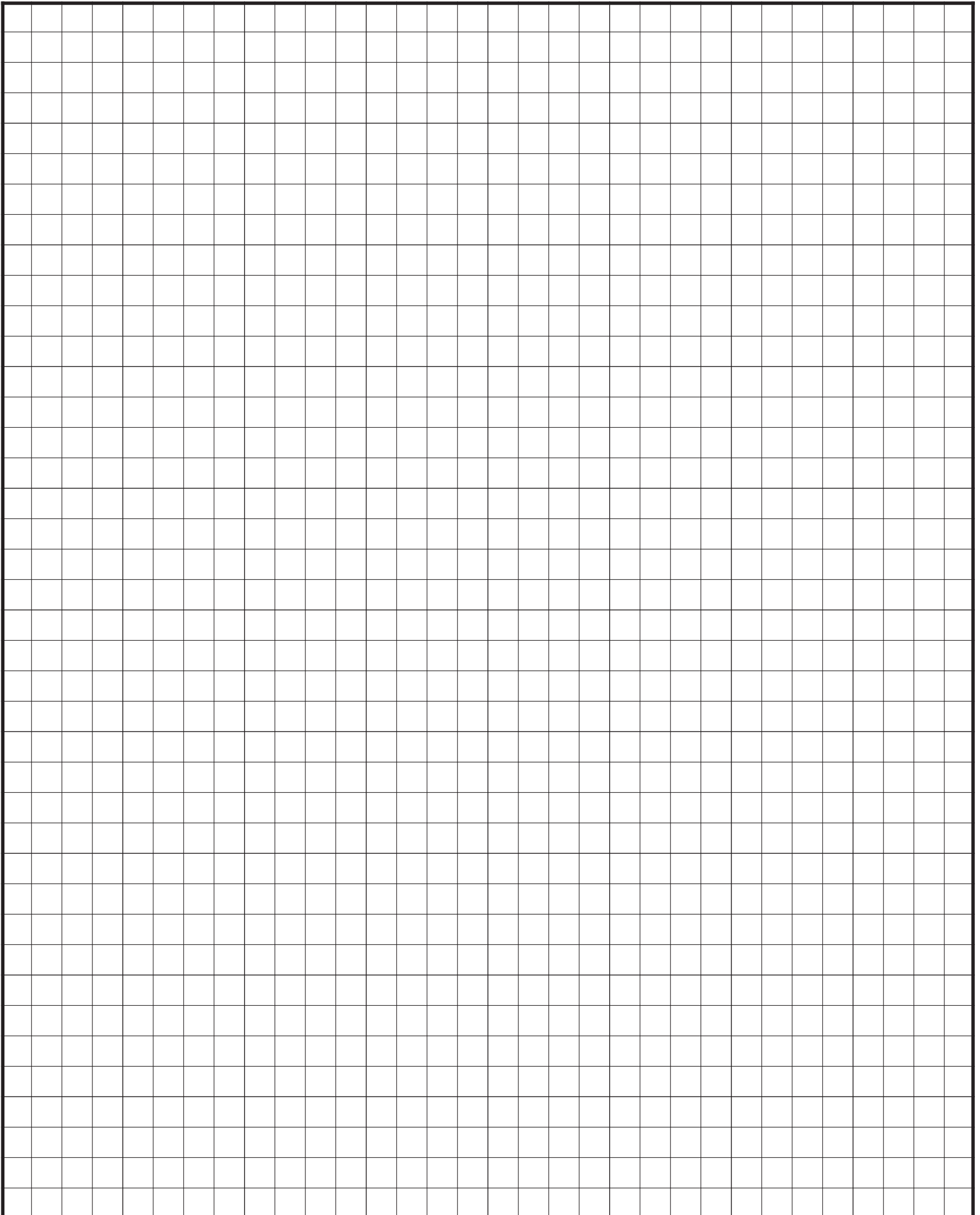





**TAYLOR**

---

**METAL PRODUCTS**

---

**QUALITY PRODUCTS**  
**EXCEPTIONAL SERVICE**

---

**SALEM BRANCH**

4566 Ridge Dr. NE  
Salem, OR 97301

Office: 503-581-8338  
Toll Free: 1-800-574-1388  
Fax: 503-581-6877

**SPOKANE BRANCH**

1010 N Nelson St.,  
Spokane, WA 99202  
[www.go-TMP.com](http://www.go-TMP.com)

Office: 509-535-8667  
Toll Free: 800-238-4057  
Fax: 509-535-8682

**AUBURN BRANCH**

2601 C St SW,  
Auburn, WA 98001

Office: 206-900-9923  
Toll Free: 1-800-574-1388  
Fax: 253-804-3545

**SACRAMENTO BRANCH**

3443 Airport Rd.  
Sacramento, CA 95834

Office: 916-318-8844  
Toll Free: 1-800-574-1388  
Fax: 916-993-4123

**RIVERSIDE BRANCH**

4880 Felspar St.  
Riverside, CA 92509

Office: 323-407-7457  
Toll Free: 1-877-504-1594